

# SmartGen

MAKING CONTROL SMARTER

## SGM/SGMA63-630A SERIES DUAL POWER AUTOMATIC TRANSFER SWITCH USER MANUAL



郑州众智科技股份有限公司  
SMARTGEN(ZHENGZHOU)TECHNOLOGY CO.,LTD.

## CONTENTS

1 OVERVIEW .....	4
2 STRUCTURE AND CHARACTERISTICS .....	4
3 OVERALL DIMENSIONS AND CATEGORY .....	5
3.1 INSTRUCTION.....	5
3.2 SGM/SGMA OVERALL DIMENSIONS AND TECHNICAL DATA .....	6
3.3 WIRINGS.....	9
4 WORKING CONDITION .....	11
5 WIRING CONNECTION DIAGRAM .....	11
5.1 SGM (Genset) .....	11
5.2 SGMA(ATS).....	12
6 INSTALLATION AND DEBUGGING .....	12
7 ORDERING MODEL .....	13

**SmartGen** Registered trademark

**No. 28 Xuemei Street, Zhengzhou, Henan, China**

**Tel:** +86-371-67988888/67981888/67992951

+86-371-67981000(overseas)

**Fax:** +86-371-67992952

**Web:** [www.smartgen.com.cn/](http://www.smartgen.com.cn/)

[www.smartgen.cn/](http://www.smartgen.cn/)

**Email:** [sales@smartgen.cn](mailto:sales@smartgen.cn)

All rights reserved. No part of this publication may be reproduced in any material form (including photocopying or storing in any medium by electronic means or other) without the written permission of the copyright holder.

SmartGen reserves the right to change the contents of this document without prior notice.

**Table 1 Software Version**

Date	Version	Content
2024-03-07	1.0	Original release.

## 1 OVERVIEW

SGM/SGMA63-630A series dual power ATS applies to the grounded power system of two neutral points, which requires AC400V 50/60Hz below, rated working current 16A~630A. Its structure is motor driven type, and there are three positions for the switch: normal ( I ), spare ( II ) and off ( 0 ). It can be used in the occasions where power failure is not allowed, such as high-rise buildings, medical health, post and telecommunications, coal mine and ships, rail traffic, military and fire facilities.

This series products comply with the standard of GB GB/T 14048.11 "Low-voltage switchgear and controlgear --- part 6-1: Multiple function equipment ---Transfer switching equipment".

## 2 STRUCTURE AND CHARACTERISTICS

SGM/SGMA63-630A series dual power ATS adopts motor-driven structure, and the appearance design is simple. The integrated manual operation handle is easy for operation and debugging; manual/remote control DIP switch can control the internal power supply. When transferring to manual mode, the manual operation is only available to ensure the personal safety. The external wirings are simple and clear, which is convenient for on-site installation and debugging.

**Table 2 Model Difference**

Model	Station	Electric Switch-off	Application
SGM (Genset)	Three	Manual Switch-off (available)	SGM series can be used for genset controller with AMF function
SGMA (ATS)	Three	●	SGMA series can be used for ATS controller

3 OVERALL DIMENSIONS AND CATEGORY

3.1 INSTRUCTION

SGM/SGMA63-630A series dual power ATS can be divided into two types according to their functions: genset type SGM series and ATS type SGMA series; while it can be divided into four types according to their shell frames: 80A/4P, 125A/4P, 250A/4P and 630A/4P. Three-pole and four-pole switches can be provided by each type, among which SGM-80/4P and SGMA-80/4P can also provide two-pole switch.

The rated current sequence of the switch includes: 63A, 80A, 100A, 125A, 160A, 200A, 250A, 400A, 630A.

The shapes of the switches are as follows:

Table 3 The Shapes of Switches

Classification	Shell Frame Model	2-pole	3-pole	4-pole
SGM (Genset Type)	SGM-80A			
			63A, 80A	
	SGM-125A SGM-250A SGM-630A	None		
			100A, 125A, 160A, 200A, 250A, 400A, 630A	

Classification	Shell Frame Model	2-pole	3-pole	4-pole
SGMA (ATS Type)	SGMA-80A			
		63A, 80A		
	SGMA-125A SGMA-250A SGMA-630A	None		
			100A,125A,160A, 200A, 250A, 400A, 630A	

3.2 SGM/SGMA OVERALL DIMENSIONS AND TECHNICAL DATA

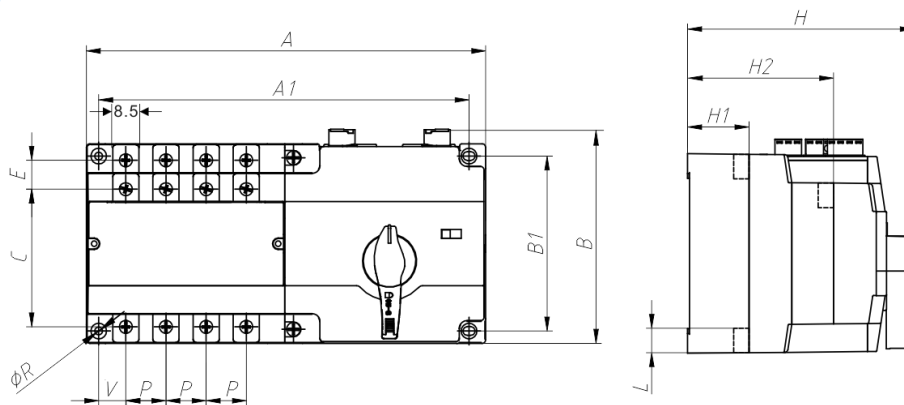

Fig.1 - SGM/SGMA-80A Shell Frame

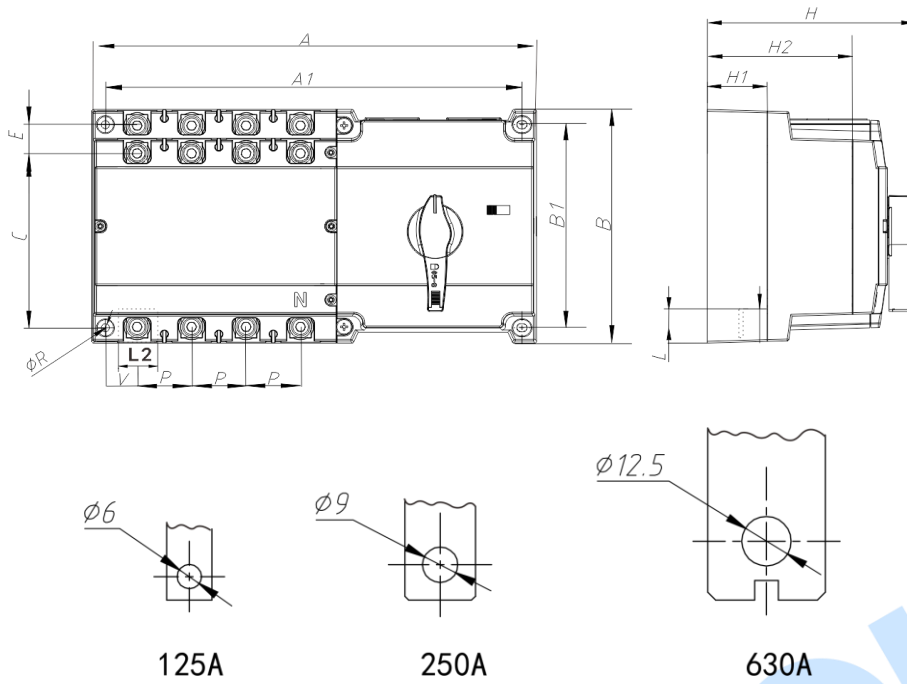

Fig.2 - SGM/SGMA-125A/250A/630A Shell Frame

Table 4 SGM/SGMA Series Overall Dimensions

Model	Dimensions (mm)			Mounting Hole Size(mm)											Copper Busbar Hole (mm)
	A	B	H	A1	B1	H1	H2	C	E	R	V	P	L	L2	φ
SGM-80A/4P SGMA-80A/4P	230	115	155	212	100	35	83	79	16.5	4	15.5	23	14	9	/
SGM-125A/4P SGMA-125A/4P	245	130	212	230	113	31	71	97.5	15.5	4.5	25	30	16	21.5	6
SGM-250A/4P SGMA-250A/4P	295	175	175	275	152	29	99	132	20	6	32	35	29	27	9
SGM-630A/4P SGMA-630A/4P	430	272	228	400	240	41	131	207	30	9	50	58	38	42	12.5

Table 5 SGM/SGMA Series Technical Parameter

Model	SGM(A) -63A /XP	SGM(A) -80A /XP	SGM(A) -100A /XP	SGM(A) -125A /XP	SGM(A) -160A /XP	SGM(A) -200A /XP	SGM(A) -250A /XP	SGM(A) -400A /XP	SGM(A) -630A /XP
Poles (P)	2-p, 3-p, 4-p			3-p, 4-p					
Rated Current	63A	80A	100A	125A	160A	200A	250A	400A	630A
Rated Volt.	AC400V								
Rated Insul. Volt.	690V								
Impulse withstand Volt.	8 kV								
Category	AC-33B								
Short-time	10 kA		10 kA		10 kA			25 kA	

Model	SGM(A) -63A /XP	SGM(A) -80A /XP	SGM(A) -100A /XP	SGM(A) -125A /XP	SGM(A) -160A /XP	SGM(A) -200A /XP	SGM(A) -250A /XP	SGM(A) -400A /XP	SGM(A) -630A /XP
Withstand Current									
Rated SC Ability	17 kA		20 kA		30 kA			50 kA	
Rated Control Supply	AC230V								
I-II or II-I Contact Trans. Time	0.6s±50%		0.6s±50%		1.0s±10%			1.5s±10%	
Operation Cycle Times	Without Current	8500	8500		7000			3000	
	With Current	1500	1500		1000			1000	
	Total	10000	10000		8000			4000	
Weight /4P	2.3kg		3.9kg		8.7kg			21.7kg	



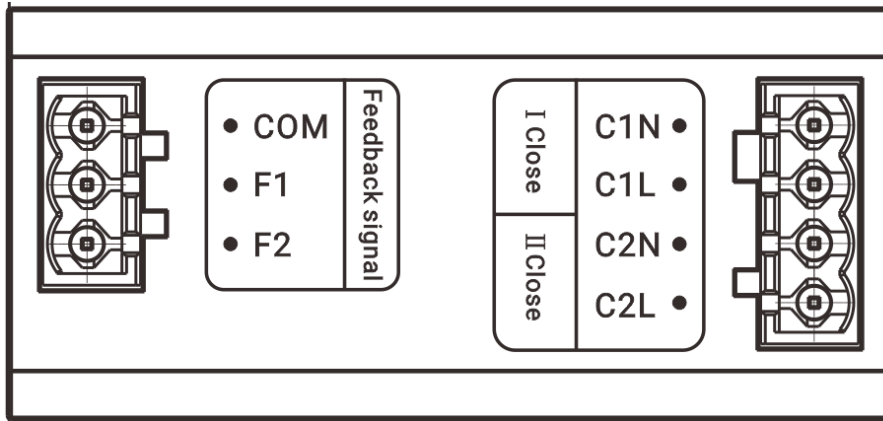

Fig.3 - SGM Series Terminal

Table 6 SGM Series Terminal Description

No.	Sign	Function	Remark
Control Terminal	1	C1N	I# Closed Control N-phase Input
	2	C1L	I# Closed Control L-phase Input
	3	C2N	II# Closed Control N-phase Input
	4	C2L	II# Closed Control L-phase Input
Feedback Terminal	1	COM	Closed Feedback COM Port
	2	F1	I# Closed Feedback Output
	3	F2	II# Closed Feedback Output
DIP Switch	Manual	Manual Control	Manual/remote control, padlocking may disable transfer when it is in manual position.
	Remote	Remote Control	Remote control is disabled when it is in manual position and cannot control the switch by controlling the terminal, only be available by manual transfer.
Manual Operation Handle	I-O-II	Position Sign	In manual mode, operation handle could be turned to I# closed/O open/II# closed position.

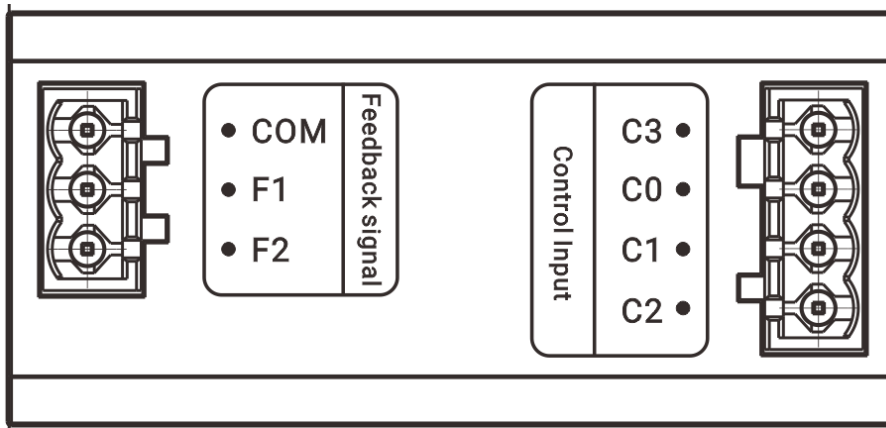

Fig.4 - SGMA Series Terminal

Table 7 SGMA Series Terminal Description

No.	Sign	Function	Remark
Control Terminal	1	C3	Common N-line Input Common N-phase input
	2	C0	Open Control Input AC230V L-phase input
	3	C1	II# Closed Control Input AC230V L-phase input
	4	C2	I# Closed Control Input AC230V L-phase
Feedback Terminal	1	COM	Closed Feedback COM Port Volts free feedback COM port
	2	F1	I# Closed Feedback Output Volts free feedback output
	3	F2	II# Closed Feedback Output Volts free feedback output
DIP Switch	Manual	Manual Control	Manual/remote control, padlocking may disable transfer when it is in manual position.
	Remote	Remote Control	Remote control is disabled when it is in manual position and cannot control the switch by controlling the terminal, only be available by manual transfer. When it is in remote position can control the switch by controlling the terminal.
Manual Operation Handle	I-O-II	Position Sign	In manual mode, operation handle could be turned to I# closed/O open/II# closed position.

4 WORKING CONDITION

Table 8 Working Condition

Item	Requirements
Working Temperature	(-25~+70)°C
Working Humidity	(20~90)%RH
Installation Height	≤2000m
Pollution Degree	3-level

5 WIRING CONNECTION DIAGRAM

5.1 SGM (Genset)

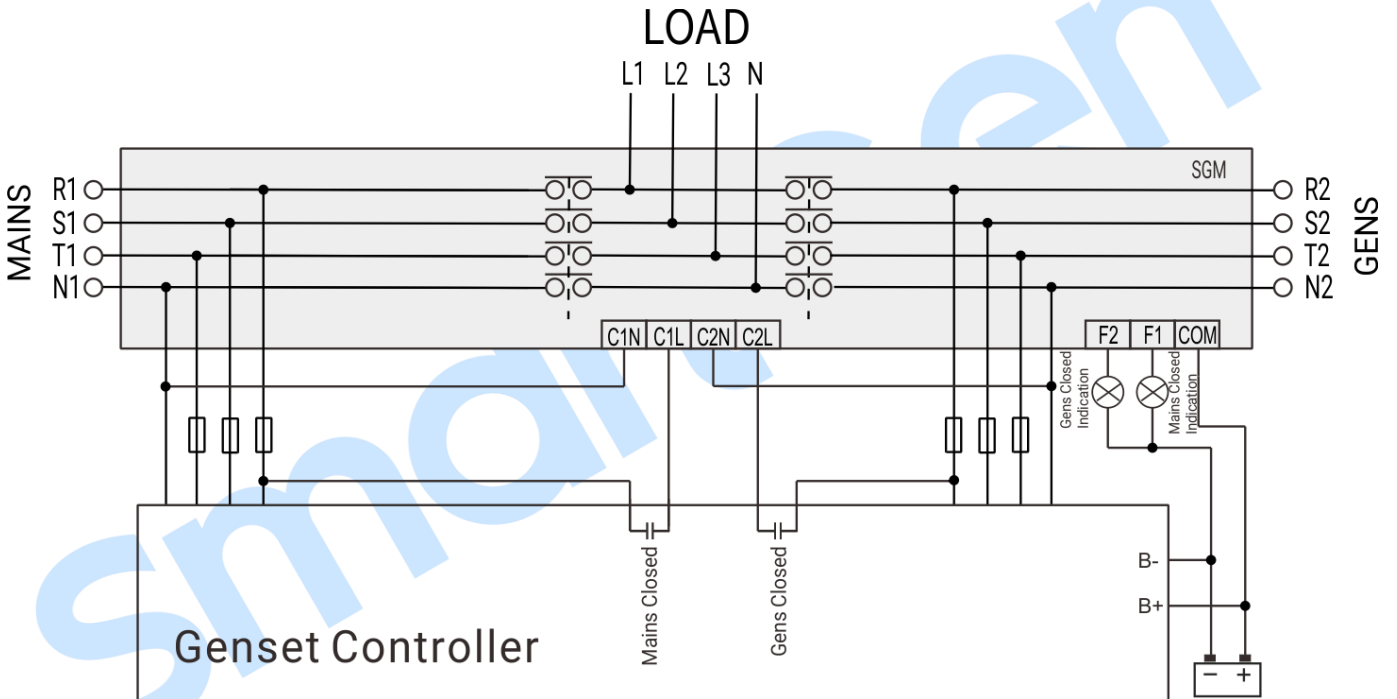

Fig.5 - SGM (Genset) Wiring Connection

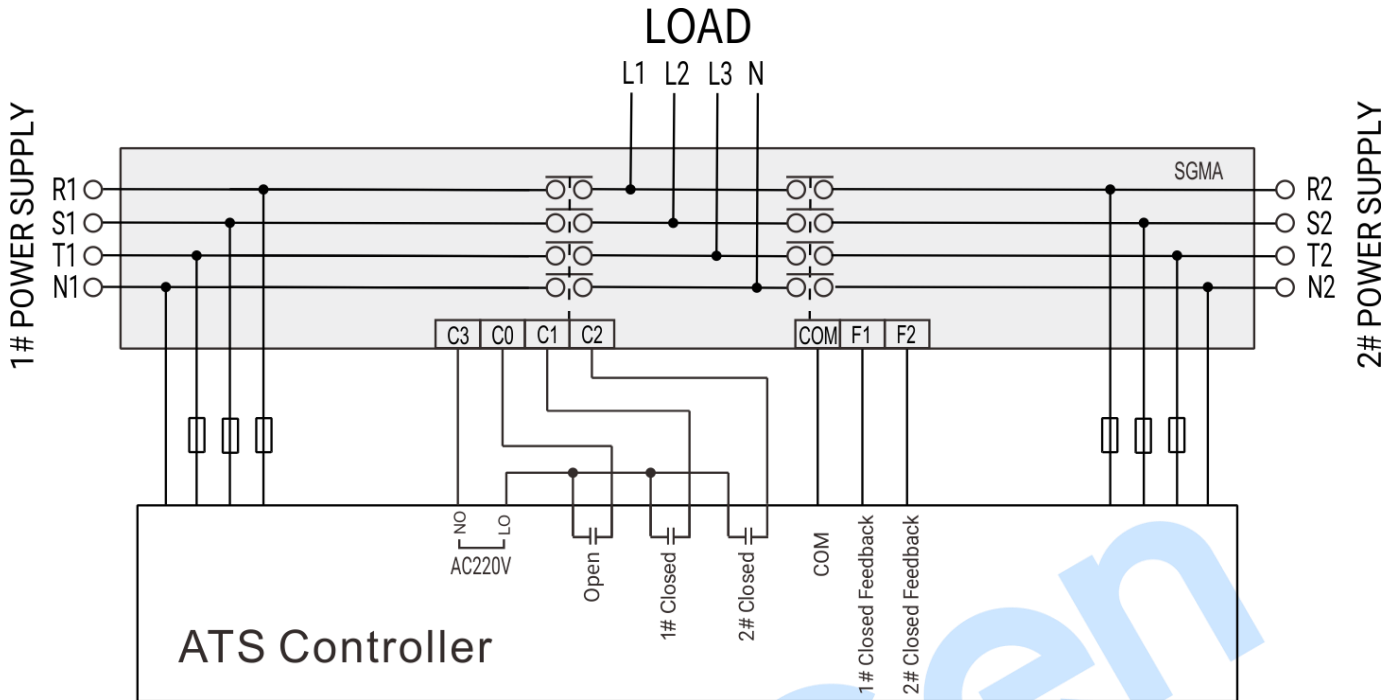
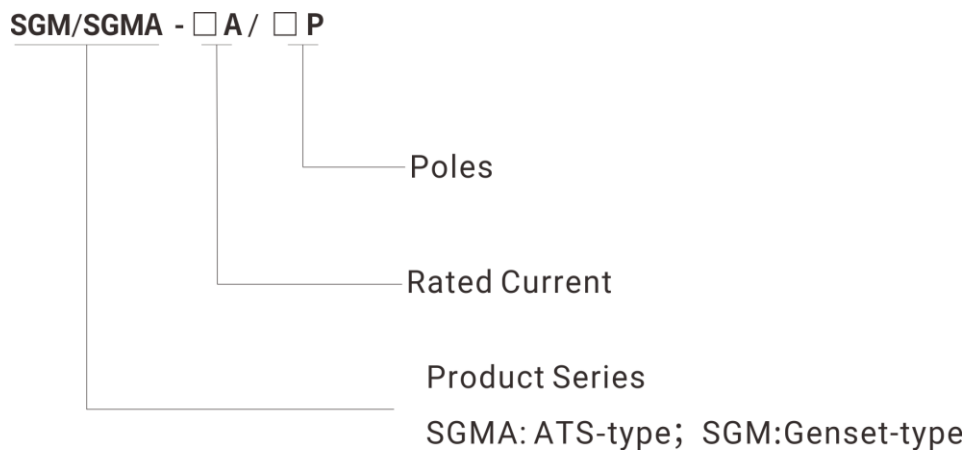

Fig.6 - SGMA (ATS) Wiring Connection

## 6 INSTALLATION AND DEBUGGING

The installation and debugging of ATS should be carried out by professionals and person who knows the switchgear, the related protections and preventive measures must be considered during operating. The wirings of main circuit must be in a way that the leads are not subjected to any pressure or force. Before installation and debugging, firstly check if the switch is damaged or has any harmful effects, meanwhile, check for loose wires may be caused in transportation; clean up the dirt, especially the dirt on the surface of insulation parts, which may be caused by package materials during transportation or storage. When connecting the primary circuit, pay attention to the phase sequence of the two power supplies that should be consistent, while connecting the secondary circuit, it should be strictly in accordance with the wiring diagram listed on the user manual, at the same time, notice that the voltage level of power supply; switch must be well grounded during installation. Considering in personal safety and the quickness of transferring, the handle is only used for debugging, users should not use the handle to operate with load. During debugging, firstly use handle to operate, then perform the electrical operation by manual button if there is nothing abnormal, finally go to the formal running.

## 7 ORDERING MODEL



NOTE: The ordering models are based on the actual product models of SmartGen.

**Fig.7 - Ordering Model**

**Table 9 Packing List**

No.	Item	Qty.
1	ATS	1
2	Installation Instructions	1
3	Arc-isolating Plate	9