



SmartGen
ideas for power

HGM8156

Genset Busbar Parallel (With Mains) Controller

USER MANUAL



SMARTGEN (ZHENGZHOU) TECHNOLOGY CO., LTD.



CONTENTS

1	OVERVIEW	6
2	PERFORMANCE AND CHARACTERISTICS	7
3	SPECIFICATION.....	8
4	OPERATION	9
4.1	INDICATORS	9
4.2	KEY FUNCTION DESCRIPTION	10
4.3	LCD DISPLAY	11
4.3.1	MAIN DISPLAY.....	11
4.3.2	PARAMETER SETTING MENU.....	12
4.3.3	PARAMETER SETTING	12
4.4	AUTO START/STOP OPERATION	12
4.5	MANUAL START/STOP OPERATION.....	13
4.6	SWITCH CONTROL PROCEDURES.....	14
4.6.1	MANUAL CONTROL PROCEDURE	14
4.6.2	AUTOMATIC CONTROL PROCEDURE	14
5	MULTI-CHANNEL MAINS OPERATION.....	15
6	PROTECTION.....	16
6.1	WARNING ALARM	16
6.2	SHUTDOWN ALARM.....	17
6.3	TRIP AND STOP ALARM.....	17
6.4	TRIP ALARM.....	18
7	WIRING CONNECTION	18
8	SCOPES AND DEFINITIONS OF PROGRAMMABLE PARAMETERS	21
8.1	CONTENTS AND SCOPES OF PARAMETERS.....	21
8.2	DEFINABLE CONTENTS OF PROGRAMMABLE OUTPUTS	27
8.2.1	DEFINABLE CONTENTS OF PROGRAMMABLE OUTPUTS	27
8.2.2	DEFINED COMBINATION OUTPUT	30
8.3	DEFINABLE CONTENTS OF PROGRAMMABLE INPUTS (GROUND CONNECTED (B-) ACTIVE).....	31
9	PARAMETER SETTING.....	33
10	COMMISSIONING.....	33
11	MAINS PARALLEL MODE	34
11.1	BUS CONTROL MODE	34



11.2	MAINS CONTROL MODE.....	35
11.3	LOAD RECEPTION MODE.....	36
11.4	AMF CONTROL MODE	37
11.5	ISLAND START MODE.....	38
12	TYPICAL APPLICATION.....	39
13	INSTALLATION.....	41
13.1	BATTERY VOLTAGE INPUT	41
13.2	OUTPUT AND EXPAND RELAYS.....	41
13.3	AC INPUT.....	41
13.4	WITHSTAND VOLTAGE TEST	41
14	ETHERNET PORT.....	42
14.1	ILLUSTRATION.....	42
14.2	NETWORK CLIENT CONNECTION.....	42
14.3	CONTROLLER AND NETWORK CABLE CONNECTION	42
14.3.1	CONTROLLER AND PC CONNECTION VIA A CABLE.....	42
14.3.2	CONTROLLER AND PC CONNECTION VIA SWITCHBOARD (OR ROUTER).....	42
15	FAULT FINDING.....	43



Chinese trademark

SmartGen English trademark

SmartGen —make your generator *smart*

SmartGen Technology Co., Ltd.

No. 28 Jinsuo Road

Zhengzhou City

Henan Province

P. R. China

Tel: +86-371-67988888/67981888/67992951

+86-371-67981000 (overseas)

Fax: +86-371-67992952

Web: www.smartgen.com.cn

www.smartgen.cn

Email: sales@smartgen.cn

All rights reserved. No part of this publication may be reproduced in any material form (including photocopying or storing in any medium by electronic means or other) without the written permission of the copyright holder.

Applications for the copyright holder’s written permission to reproduce any part of this publication should be addressed to SmartGen Technology at the address above.

Any reference to trademarked product names used within this publication is owned by their respective companies.



SmartGen Technology reserves the right to change the contents of this document without prior notice.

Table 1 Software Version

Date	Version	Content
2019-08-02	1.0	Original release
2019-09-10	1.1	Added characteristic description.
2021-04-20	1.2	Modified the error in indicators status description.

This manual is only applicable for HGM8156 Controller.

Table 2 Notation Clarification

Symbol	Instruction
 NOTE	Highlights an essential element of a procedure to ensure correctness.
 CAUTION!	Indicates a procedure or practice, which, if not strictly observed, could result in damage or destruction of equipment.
 WARNING!	Indicates a procedure or practice, which could result in injury to personnel or loss of life if not followed correctly.

SmartGen

1 OVERVIEW

HGM8156 Genset Busbar Parallel (with Mains) Controller is especially designed for extremely high/low temperature environment (-40~+70)°C. It applies self-luminous Vacuum Fluorescent Display (VFD) and electronic components with extreme high/low temperature resistance, therefore it can work reliably under extreme temperature conditions. After careful consideration for the electromagnetic compatibility on different occasions in designing process, it provides strong guarantee for it to work under complex electromagnetic interference environment. It is plug-in wiring terminal structure, which is convenient for product maintenance and upgrade. Chinese, English, and other various languages can be displayed on controller.

HGM8156 Genset Busbar Parallel (with Mains) Controller suits the manual/auto parallel system of multiple gensets with single or multi-channel mains, realizing auto start/stop parallel operation of multiple gensets. Graphic display is applied. Operation is simple, and working is reliable. There are also multiple options that can be selected of parallel running mode with mains, for example: constant active power and reactive power/power factor mode of genset output; mains peak clipping mode; constant power mode outputted to mains; load taking mode; incessant recovering to mains supply function. It employs 32-bit micro-processor technology, realizing functions of precise measuring for most parameters, set value adjustment, timing and fixed value adjustment etc. Most parameters can be regulated from front panel, and all parameters can be adjusted via USB on PC. And parameters can also be regulated and monitored via RS485 or Ethernet on PC. It can be used widely in various genset automatic parallel systems.

2 PERFORMANCE AND CHARACTERISTICS

Main characteristics are as below:

- With ARM-based 32-bit SCM, it has high hardware integration, and reliability is promoted to a great degree.
- Graphic dot-matrix VFD, Chinese/English are optional, and can be selected on site, which provides convenience for debugging persons.
- Acrylic material of hard screen for protection, with better wear resisting and scratch resistant performance;
- Silicon panel and button, which makes it have stronger adaptability for high/low environment;
- RS485 communication port, which can realize “three remotes” function with ModBus protocol;
- Ethernet communication port, realizing Ethernet monitoring (it needs to use controller with Ethernet port);
- Suitable for (120/240V) power, 50/60Hz system of 3-phase 4-wire, 3-phase 3-wire, single phase 2-wire, 2-phase 3 wire;
- Collect and display 3-phase voltage, A-phase current, frequency, and power factor of busbar;
- Collect and display 3-phase voltage, 3-phase current, frequency, and power factor of mains;
- Complete mains parallel off protection function, over frequency, under frequency, over voltage, under voltage, frequency change ratio, vector change;
- Synchronizing parameters are: voltage difference between busbar and mains, frequency difference between busbar and mains, phase angle difference between busbar and mains;
- Multiple working modes in auto status: auto start at mains inactive, island running, input/output constant power, peak clipping mode, load taking mode;
- Soft load shift function at parallel and parallel off;
- Control protection function: realizes diesel genset auto start/stop, breaker close/open, and thorough fault display protection functions;
- All outputs are relay outputs;
- Parameter setting function: allows users to change and set parameters, and this will be restored in internal FLASH memory, and will not lose at power outage. A majority of parameters can be adjusted on front panel, and all parameters can be regulated by USB port on PC, or by RS485/Ethernet port on PC;
- Power supply range DC(8~35)V, which can suit different starter battery voltage environment;
- Event Log, Real Time Clock, Scheduled Start/Stop (once per month/week/day, and loading or not can also be set) functions;
- Can be used as indicating instrument (only indication, alarm and relay doesn't act);
- Maintenance function, maintenance time due actions can be set;
- All parameters are adjusted by digitalization, getting rid of analog adjustment of traditional potentiometer, improving reliability and stability of whole controller;
- Sealing gasket is designed between enclosure and panel window; waterproof level is IP55;
- Metal clips are used to fix the controller, which has outstanding performance in high temperature;
- Modular structure design, pluggable wiring terminal, build-in installation with compact structure and easy mounting features.

3 SPECIFICATION

Table 3 Technical Parameters

Parameter	Details
Working Voltage	DC8. 0V to 35. 0V, continuous power supply
Overall Consumption	<4W (Standby mode: ≤2W)
AC Input:	
3 Phase 4 Wire	AC 15V - 360V (ph-N)
3 Phase 3 Wire	AC 30V - 620V (ph-ph)
Single Phase 2 Wire	AC 15V - 360V (ph-N)
2 Phase 3 Wire	AC 15V - 360V (ph-N)
AC Frequency	50Hz/60Hz
Flexible Relay Output 1	7A DC28V power supply output
Flexible Relay Output 2	7A DC28V power supply output
Flexible Relay Output 3	7A DC28V power supply output
Flexible Relay Output 4	7A AC250V volts free output
Flexible Relay Output 5	8A AC250V volts free output
Flexible Relay Output 6	8A AC250V volts free output
Flexible Relay Output 7	16A DC28V power supply output
Flexible Relay Output 8	16A DC28V power supply output
Case Dimensions	242mm×186mm×53mm
Panel Cutout	214mm×160mm
CT Secondary Current	Rated 5A
Working Conditions	Temperature: (-40~+70)°C Humidity: (20~93)%RH
Storage Conditions	Temperature: (-40~+70)°C
Protection Level	IP55 Gasket: when sealing gasket is installed between enclosure and panel window;
Insulation Intensity	Apply AC2.2kV voltage between high voltage terminal and low voltage terminal and the leakage current is not more than 3mA within 1min.
Weight	0.85kg

4 OPERATION

4.1 INDICATORS

Description for a part of indicators:

Table 4 Alarm Indicators

Alarm Type	Alarm Indicator
No Alarm	Indicator off
Warning	Slow flashing (1 time/s)
Trip Alarm	Slow flashing (1 time/s)
Shutdown Alarm	Fast flashing (5 times/s)
Trip and Stop Alarm	Fast flashing (5 times/s)















Status indicator: extinguishes at standby mode, and illuminates always for other periods;

Busbar normal indicator: light on always when busbar is normal; flashes when generating is abnormal; extinguishes when there is no generating power.

Mains normal indicator: light on always when mains is normal; flashes when mains is abnormal; extinguishes when there is no mains.

4.2 KEY FUNCTION DESCRIPTION

Table 5 Key Description

Icons	Keys	Description
	Stop	In manual/auto mode, press and controller will issue stop command, and can stop all running gensets that are permitted to be stopped (in auto mode); In stop mode, press and it can reset alarms; Press for over 3s, and it can test whether panel indicators are normal (lamp test).
	Start	In manual mode, press and controller will issue start command, and can start all gensets that are allowed to start (in auto mode).
	Manual Mode	Press and it can put controller in manual mode.
	Auto Mode	Press and it can put controller in auto mode.
	Mute/Reset Alarm	Clear up alarm sound; Reset trip alarm by pressing over 3s if trip (not shutdown) alarm occurs.
	Bus Close/Open	Control busbar close/open in manual mode.
	Mains Close/Open	Control mains close/open in manual mode.
	Set	Press and enter setting screen.
	Up/Increase	1) Screen scroll; 2) Move up cursor and increase value in setting menu.
	Down/Decrease	1) Screen scroll; 2) Move down cursor and decrease value in setting menu.
	Left	1) Page scroll; 2) Left move cursor in setting menu.
	Right	1) Page scroll; 2) Right move cursor in setting menu.
	Confirm	Confirm the inputted content in setting menu.
	Exit	1) Return to main screen; 2) Return to previous menu in setting menu.

CAUTION! Default password is “00318”. Operator can change it in case others change the advanced parameter settings. Please clearly remember the password after changing. If you forget it, please contact SmartGen services and feedback PD information in controller **ABOUT** page to us.

4.3 LCD DISPLAY

4.3.1 MAIN DISPLAY

Main screen is displayed by pagination.  is used to scroll the pages and  is to scroll the screens.

Main Screen includes the following:

- A part of statuses;
- Bus: voltage, frequency, active power, reactive power;
- Mains: voltage, frequency, current, active power, reactive power.

NOTE: Main screens will circularly display if there is no scroll operation.

Status includes the following: genset status, switch status, mains status.

Mains includes the following:

Phase voltage, wire voltage, frequency, phase sequence, each phase current, each phase and total active power (positive and negative), each phase and total reactive power (positive and negative), each phase and total apparent power, each phase and average power factor (positive and negative), total electric energy, ground current, unbalanced current, total electric energy of user A and B.

NOTE: Power factor display illustration:

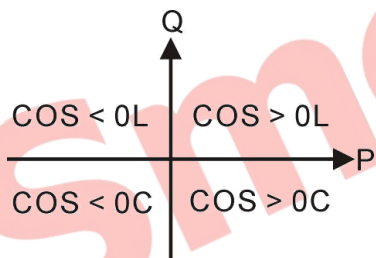

NOTE:

P stands for active power;
Q stands for reactive power.

Table 6 Power Factor Illustration

Power Factor	Conditions	Active Power	Reactive Power	Remark
COS>0L	P>0,Q>0	Input	Input	Load is resistor-inductance.
COS>0C	P>0,Q<0	Input	Output	Load is resistor-capacitance.
COS<0L	P<0,Q>0	Output	Input	Load is equal to an under excitation generator.
COS<0C	P<0,Q<0	Output	Output	Load is equal to an over excitation generator.

NOTE:

1. Input active power, genset or mains sends electricity to load.
2. Output active power, load supplies electricity to genset or mains.
3. Input reactive power, genset or mains sends reactive power to load.
4. Output reactive power, load sends reactive power to genset or mains.

Bus includes the following: phase voltage, line voltage, frequency, phase sequence, current, power etc.

SNYC includes the following: synchronous table, power percentage, MSC status etc.

Alarm displays all alarm information, including: warning, shutdown alarm, trip and shutdown and trip but not shutdown.

Event log: records all start/stop events (shutdown alarm, trip and shutdown alarm, manual/auto start/stop), real time of occurred alarms, and genset parameters.

Others includes: time and date, battery voltage, maintenance countdown, input/output ports status, network settings etc.

About includes: released software and hardware version, product PD number.

4.3.2 PARAMETER SETTING MENU

Press  key and enter user menu:

- **Parameter:** Input correct password (factory default is 00318) and you can enter parameter setting screen.
- **Language:** Simplified Chinese, English and others are optional (others default: Espanol).
- **Commissioning:** On load, off load or defined commissioning can be selected. On load or off load, commissioning time, after-commissioning mode (manual mode, auto mode, stop mode) can be set for defined commissioning.
- **Clear users' accumulation:** total electric energy A, and total electric energy B can be cleared up.

4.3.3 PARAMETER SETTING

- Mains Set
- Timers set
- Battery set
- Bus set
- Switch set
- Switch input port set
- Output port set
- Module set
- Scheduling and maintenance set
- Synchronization set

NOTE: press  and parameter setting can exit directly in setting process.

4.4 AUTO START/STOP OPERATION

Press  and indicator beside shall be illuminated, which means genset is in auto mode.

- **Automatic Start Sequence:**



- 1) When "Remote Start" (on load) is active or mains is abnormal, "Start Delay" timer is initiated; "Start Delay" countdown will be displayed;
- 2) After start delay, controller issues start command, and displays "Start Request" countdown;
- 3) If genset is in auto mode, it will enter auto start process, for which please refer to user manual;
- 4) When least started gensets number is reached, controller enters normal running:
 - a) If mains is not closed, bus close relay outputs;
 - b) If mains is closed, controller will automatically regulate genset speed and voltage on the bus, in order to synchronize with mains; when requirements are met, bus close relay outputs and make bus parallel with mains; controller will control soft load transfer. After load shift it will do load share normally.
- 5) If least started genset number is not reached when start request delay is over, controller will issue start genset few alarm.



NOTE: When genset start is triggered by remote start (off load) input, process is the same as above; the only thing is bus close relay doesn't output and bus doesn't take load. When remote start (on demand) input is active, if start conditions are satisfied (for example: in mains peak clipping mode, load is above mains pre-set output value), process is the same as above.

— **Automatic Stop Sequence:**

- 1) When remote start input is active and mains is normal, "Stop Delay" is started;
- 2) When stop delay is over,
 - a) If mains is not closed, bus open relay outputs;
 - b) If mains is closed, controller will soft transfer load to mains; after load transfer is over, bus open relay outputs;
- 3) Controller issues stop command, and enters standby status;
- 4) If genset is in auto mode, genset enters auto stop process; For this process please refer to controller user manual.

4.5 MANUAL START/STOP OPERATION

— **Manual Start:**

- 1) Press  and indicator beside is illuminated, which means genset is in manual start mode.
- 2) Press  and controller enters start process. Controller issues start command and displays "Start Request" countdown;
- 3) If genset is in auto mode, genset enters auto start process, for which please refer to user manual.
- 4) If least start genset number is reached, controller enters normal running.
- 5) If when start request delay is over, genset number is still not reached, controller will issue genset number few alarm.

— **Manual Stop:**

- 1) Press  and indicator beside is illuminated, which means controller is in stop mode.
Controller enters stop process:
 - a) If mains is not closed, bus open relay outputs directly;



- b) If mains is closed, controller will soft transfer load to mains; when load transfer is over, bus open relay outputs;
- 2) Controller issues stop command and enters standby mode;
- 3) If genset is in auto mode, it will enter auto stop process, for which please refer to controller user manual.

4.6 SWITCH CONTROL PROCEDURES

4.6.1 MANUAL CONTROL PROCEDURE

When controller is in manual mode, switch control process is conducted manually. Breaker close/open is controlled by close/open key.

Bus Close Operation: In normal running process, press bus  key,

- 1) When mains is not closed, bus close relay outputs;
- 2) When mains is already closed, controller will regulate genset speed and voltage on the bus automatically to synchronize genset with mains. When synchronization conditions are satisfied, bus close relay outputs and parallel genset with mains. Controller will control soft load transfer, and after the transfer it will do load share normally.

Bus Open Operation: Press bus  key,

- 1) When mains is not closed, bus open relay outputs directly;
- 2) When mains is closed already, controller firstly soft transfers load to mains, and after transfer bus open relay outputs.

Mains Close Operation: When mains is normal, press mains  key,

- 1) When bus is not closed, mains close relay outputs;
- 2) When bus is closed already, controller shall regulate genset speed and voltage on the bus automatically to make bus synchronizing with mains. When conditions are met, mains close relay outputs, and parallel mains with bus. Controller controls soft load transfer, and after the transfer, it will do normal load share.

Mains Open Operation: Press mains  key,

- 1) When bus is not closed, mains open relay outputs directly;
- 2) When bus is closed already, controller first will soft transfer load to bus, and after load transfer then mains open relay outputs.

4.6.2 AUTOMATIC CONTROL PROCEDURE

When controller is in auto mode, the switch control procedure is automatic control procedure.

NOTE: Auxiliary input of breaker close must be configured for input port, and wiring must be connected correctly.

5 MULTI-CHANNEL MAINS OPERATION

In multi-channel mains system, multiple gensets are controlled by HGM8156 and they supply multiple load. If something abnormal occurs for one channel mains, controller will control genset to start and take load. If something abnormal occurs for multiple channels, controller will control genset to take load one by one. When there is only one mains channel normal, controller will control switch and make mains take the load. When multiple mains channels are normal, controller will control mains to take the load one by one.

HGM8156 priority includes status priority and module priority. When status priorities are different, priority is decided by status. When status priorities are the same, the priority is decided by module priority. Module priority can be set by users, but status priority cannot.

Table 7 Status Priority

Status Priority	Conditions
<div style="text-align: center;"> <p>High</p>  <p>Low</p> </div>	Auto mode, mains failure, bus unloading
	Auto mode, mains recover
	Auto mode, mains failure, bus loading
	Auto mode, mains normal, request to control gensets
	Manual mode, gensets ready to run, or are running
	Auto mode, mains normal
	Manual mode, gensets not start
	Stop mode

6 PROTECTION

6.1 WARNING ALARM

When controller detects warning signals, it only issues warnings, not shutdown the genset.

Table 8 Warning Alarm

No.	Type	Description
1	Battery Over Volt	When the controller detects that genset battery voltage has exceeded the pre-set value, it will initiate a warning alarm.
2	Battery Under Volt	When the controller detects that genset battery voltage has fallen below the pre-set value, it will initiate a warning alarm.
3	Maintenance Time Due	When count down time is 0 and the action is selected "Warn", it will initiate a warning alarm.
4	Digital Input	When digital input port is set as warning and the alarm is active, it will initiate a warning alarm.
5	Fail to Sync	When the controller does not detect synchronization signal within the pre-set synchronization time, it will initiate a warning alarm.
6	Genset Number Few	Least start genset number is not reached when start request delay is over, it will initiate a warning alarm.
7	Bus Capacity Low	When current power percentage of bus is above 100% and alarm action is selected "Warn", it will initiate a warning alarm.
8	Mains Output Power Limit	When mains power is above pre-set output power limit and alarm action is selected "Warn", it will initiate a warning alarm.
9	Mains Over Freq	When controller detects mains frequency is over pre-set limit, it initiates a warning signal.
10	Mains Under Freq	When controller detects mains frequency is below pre-set limit, it initiates a warning signal.
11	Mains Over Voltage	When controller detects mains voltage is over pre-set limit, it initiates a warning signal.
12	Mains Under Voltage	When controller detects mains voltage is below pre-set limit, it initiates a warning signal.
13	Mains ROCOF	When controller detects mains ROCOF is over pre-set limit, it initiates a warning signal.
14	Mains Vector Shift	When controller detects mains vector change is over pre-set limit, it initiates a warning signal.

6.2 SHUTDOWN ALARM

When controller detects shutdown alarm, it will cutoff bus close signal and issues stop signal immediately.

Table 9 Shutdown Alarm

No.	Type	Description
1	Gen Phase Sequence Wrong	When the controller detects phase sequence wrong, it will initiate a shutdown alarm.
2	Volt Bus Phase Sequence Wrong	When the controller detects mains phase sequence wrong, it will initiate a shutdown alarm.

6.3 TRIP AND STOP ALARM

When controller detects trip and stop alarm signal, it immediately disconnects bus close signal, and issues stop signal.

Table 10 Trip and Stop Alarm

No.	Type	Description
1	Maintenance Time Due	When countdown time is 0 and the action is selected "Trip and Stop", it will initiate a trip and stop alarm.
2	Digital Input	When digital input port is set as "Trip and Stop" and the alarm is active, it will initiate a trip and stop alarm.
3	Mains Over Freq	When the controller detects that the mains frequency has exceeded the pre-set value, it will initiate a trip and stop alarm.
4	Mains Under Freq	When the controller detects that the mains frequency has fallen below the pre-set value, it will initiate a trip and stop alarm.
5	Mains Over Voltage	When the controller detects that the mains voltage has exceeded the pre-set value, it will initiate a trip and stop alarm.
6	Mains Under Voltage	When the controller detects that the mains voltage has fallen below the pre-set value, it will initiate a trip and stop alarm.
7	Mains ROCOF	When the controller detects that the ROCOF (change rate of frequency) has exceeded the pre-set value, it will initiate a trip and stop alarm.
8	Mains Vector Shift	When the controller detects that vector shift value has exceeded the pre-set value, it will initiate a trip and stop alarm.

6.4 TRIP ALARM

When controller detects trip alarm signal, it immediately disconnects the bus close signal, but genset doesn't stop.

Table 11 Trip Alarm

No.	Type	Description
1	Maintenance Time Due	When maintenance countdown is 0 and action is selected as "Trip", controller will initiate a trip alarm.
2	Digital Input	When digital input port is set as "Trip" and the alarm is active, it will initiate a trip alarm.
3	Gen Breaker Failure	When controller detects gen breaker close/open failure, it will initiate a trip alarm.
4	Mains Breaker Failure	When controller detects mains breaker close/open failure, it will initiate a trip alarm.

7 WIRING CONNECTION

Controller back panel is as below:

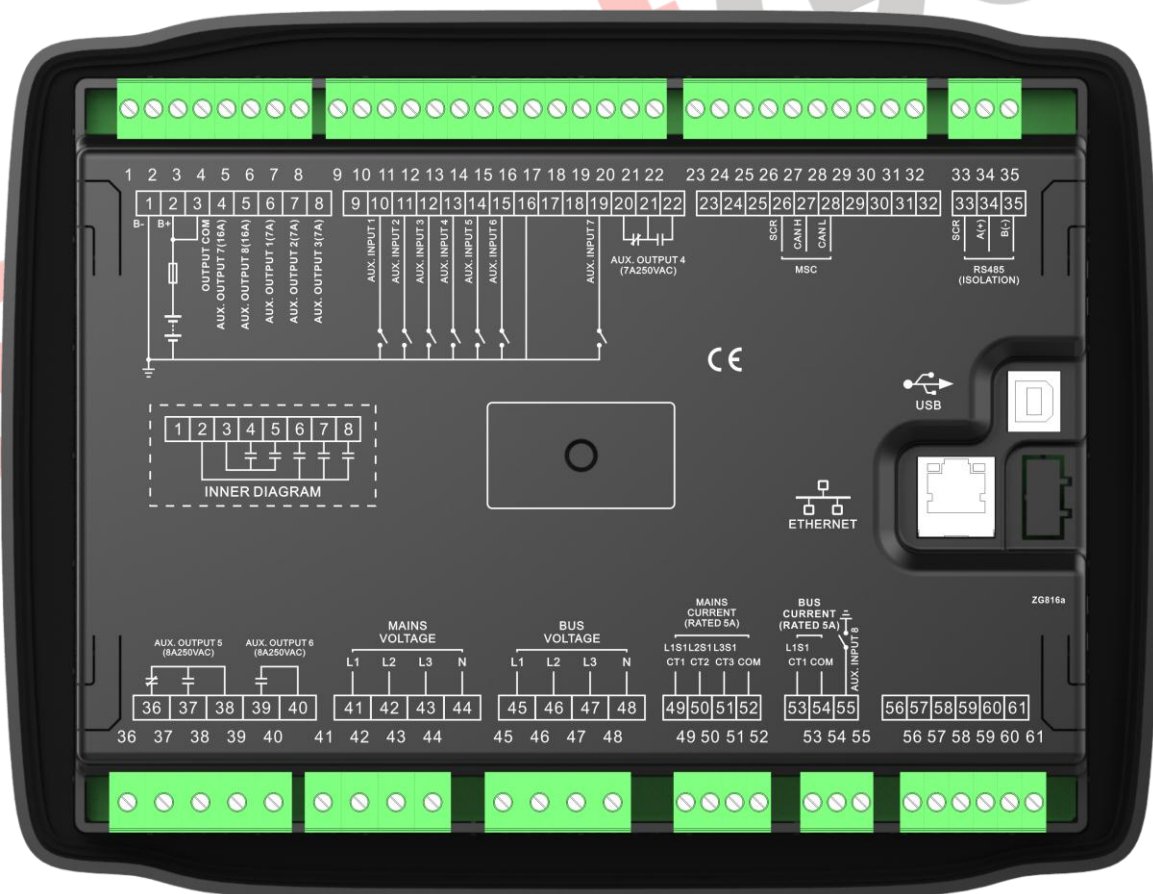

Fig. 1 Controller Back Panel



Table 12 Terminal Connection Description

No.	Functions	Cable Size	Remark
1	B-	2.5mm ²	Connects negative of starting battery.
2	B+	2.5mm ²	Connects positive of starting battery.
3	Output 7&8 COM	2.5mm ²	Connects B+.
4	Aux. output 7	1.5mm ²	B+ is supplied by 3 points, rated 16A.
5	Aux. output 8	1.5mm ²	B+ is supplied by 3 points, rated 16A.
6	Aux. output 1	1.5mm ²	B+ is supplied by 2 points, rated 7A.
7	Aux. output 2	1.5mm ²	B+ is supplied by 2 points, rated 7A.
8	Aux. output 3	1.5mm ²	B+ is supplied by 2 points, rated 7A.
9	Reserved	/	Reserved terminal; Please don't connect wires.
10	Aux. input 1	1.0mm ²	Ground connected is active (B-).
11	Aux. input 2	1.0mm ²	Ground connected is active (B-).
12	Aux. input 3	1.0mm ²	Ground connected is active (B-).
13	Aux. input 4	1.0mm ²	Ground connected is active (B-).
14	Aux. input 5	1.0mm ²	Ground connected is active (B-).
15	Aux. input 6	1.0mm ²	Ground connected is active (B-).
16	Reserved	/	Reserved terminal; Please don't connect wires.
17			
18			
19	Aux. input 7	1.0mm ²	Ground connected is active (B-).
20	Aux. output 4	1.5mm ²	Normally close outputs, rated 7A.
21			Public points of relay.
22			Normally open outputs, rated 7A.
23	Reserved	/	Reserved terminal; Please don't connect wires.
24			
25			
26	MSC CAN COM (GND)	/	Impedance-120Ω shielding wire is recommended with single end earth connected.
27	MSC CAN H	0.5mm ²	
28	MSC CAN L	0.5mm ²	
29	Reserved	/	Reserved terminal; Please don't connect wires.
30			
31			
32			
33	RS485 COM(GND)	/	Impedance-120Ω shielding wire is recommended with single end earth connected.
34	RS485A(+)	0.5mm ²	
35	RS485B(-)	0.5mm ²	
36	Aux. output 5	2.5mm ²	Normally close outputs, rated 8A.
37		2.5mm ²	Normally open outputs, rated 8A.



No.	Functions	Cable Size	Remark	
38		2.5mm ²	Public points of relay.	Table 14.
39	Aux. output 6	2.5mm ²	Normally open outputs, rated 8A.	
40		2.5mm ²	Public points of relay.	
41	Mains A-phase voltage input	1.0mm ²	Connects to A-phase of mains (2A fuse is recommended) .	
42	Mains B-phase voltage input	1.0mm ²	Connects to B-phase of mains (2A fuse is recommended).	
43	Mains C-phase voltage input	1.0mm ²	Connects to C-phase of mains (2A fuse is recommended).	
44	Mains N-wire input	1.0mm ²	Connects to N-wire of mains	
45	Gen Bus A-phase voltage input	1.0mm ²	Connects to A-phase of gen bus output (2A fuse is recommended).	
46	Gen Bus B-phase voltage input	1.0mm ²	Connects to B-phase of gen bus output (2A fuse is recommended).	
47	Gen Bus C-phase voltage input	1.0mm ²	Connects to C-phase of gen bus output (2A fuse is recommended).	
48	Gen Bus N-wire input	1.0mm ²	Connects to N-wire of gen bus output.	
49	CT A-phase input	1.5mm ²	Outside connects to secondary coil of CT (rated 5A).	
50	CT B-phase input	1.5mm ²	Outside connects to secondary coil of CT (rated 5A).	
51	CT C-phase input	1.5mm ²	Outside connects to secondary coil of CT (rated 5A).	
52	CT COM	1.5mm ²	Refer to following installation instruction.	
53	Gen Bus A-phase current input	1.5mm ²	Outside connects secondary coil of CT (rated 5A).	
54		1.5mm ²		
55	Aux. Input 8	1.0mm ²	Ground connected is active (B-).	For details please see Table 15.
56	Reserved	/	Reserved terminal; Please don't connect wires.	
57				
58				
59				
60				
61				

NOTE1: USB port on back panel is parameter configuration port and can set controller on PC.

NOTE2: Ethernet port on back panel is network monitoring port, and can monitor controller on PC.

8 SCOPES AND DEFINITIONS OF PROGRAMMABLE PARAMETERS

8.1 CONTENTS AND SCOPES OF PARAMETERS

Table 13 Parameter Setting Contents and Scope

No.	Items	Range	Defaults	Description
Mains Setting				
1	AC System	(0~3)	0	0: 3P4W; 1: 3P3W; 2: 2P3W; 3: 1P2W.
2	Rated Voltage	(30~30000)V	230	Provide standard for mains over/under voltage detection; it is primary voltage of CT; When AC system is 3P3W, it is wire voltage; for other systems, it is phase voltage.
3	Rated Frequency	(10.0~75.0)Hz	50.0	Provide standard for mains over/under frequency detection.
4	Normal Time	(0~3600)s	10	Check time for mains from abnormal to normal.
5	Abnormal Time	(0~3600)s	5	Check time for mains from normal to abnormal.
6	PT Fitted	(0~1)	0	0: Disable; 1: Enable
7	Over Voltage	(0~200)%	120	Rated voltage percentage; return value (default 116%) and delay value (default 5s) can also be set.
8	Under Voltage	(0~200)%	80	Rated voltage percentage; return value (default 84%) and delay value (default 5s) can also be set.
9	Over Frequency	(0~200)%	114	Rated frequency percentage; return value (default 110%) and delay value (default 5s) can also be set.
10	Under Frequency	(0~200)%	90	Rated frequency percentage; return value (default 94%) and delay value (default 5s) can also be set.
11	CT Ratio	(5~6000)/5	500	Ratio of externally connected CT.
12	Full-load Active Power	(1~60000)kW	345	Full-load active power of mains, used for load share.
13	Full-load Reactive Power	(1~60000)kvar	258	Full-load reactive power of mains, used for load share.
14	Disconnect Alarm Action	(0~1)	0	0: Electrical Trip; 1: Aux. Mains Failure



No.	Items	Range	Defaults	Description
15	Over Voltage	(0~200)%	105	Rated voltage percentage; alarm action (default: trip and stop) and delay value (default: 0.1s) can also be set.
16	Under Voltage	(0~200)%	95	
17	Over Frequency	(0~200)%	105	Rated frequency percentage; alarm action (default: trip and stop) and delay value (default: 0.1s) can also be set.
18	Under Frequency	(0~200)%	95	
19	ROCOF	(0~1.00)Hz/s	0.20	Set value is ROCOF; alarm action (default: trip and stop) and delay value (default: 0.1s) can also be set.
20	VECTOR SHIFT	(0~20.0)°	6.0	Set value is Vector Shift; alarm action (default: trip and stop) and delay value (default: 0.1s) can also be set.
Timer Setting				
1	Start Delay	(0~3600)s	5	Time from remote start signal is active to genset start.
2	Stop Delay	(0~3600)s	30	Time from remote start signal is inactive to genset stop.
Battery Setting				
1	Rated Voltage	(0~60.0)V	24.0	Provide standard for battery under/over voltage detection.
2	Over Voltage Warn	(0~200)%	120	Rated voltage percentage; return value (over voltage return value default: 115, under voltage return value default: 90) and delay value (default: 60s) can also be set.
3	Under Voltage Warn	(0~200)%	85	
Bus Setting				
1	AC System	(0~3)	0	0: 3P4W; 1: 3P3W; 2: 2P3W; 3: 1P2W.
2	Rated Voltage	(30~30000)V	230	If PT is fitted, it is also primary voltage when voltage transformer is used.
3	Rated Frequency	(10.0~75.0)Hz	50.0	Standards for detecting over/under frequency.
4	Volt. Trans.(PT)	(0~1)	0	0: Disable; 1: Enable
5	Full-load Active Power	(1~60000)kW	276	Active power of bus full load, used for load share.
6	Full-load Inactive Power	(1~60000)kVar	210	Reactive power of bus full load, used for load share.
7	Load Ramp Rate	(0.1~100.0)%	3.0	Load/unload rate %/s.
8	Ramp Delay Point	(0.1~40.0)%	10.0	Each time load value is added by this point, after this delay it will continue loading.
9	Load Ramp Delay	(0~30)s	0	
10	CT Enable	(0~1)	0	0: Disable; 1: Enable



No.	Items	Range	Defaults	Description
11	CT Ratio	(5~12000)/5	500	External CT ratio.
12	Capacity Delay Low	(0~1800)s	20	When bus power percentage is above 100%, after this delay, it will issue alarm based on pre-set alarm action. Action 0: Warn 1: Trip 2: Trip and Stop
13	Capacity Action Low	(0~2)	0	
Switch Setting				
1	Close Time	(0~20.0)s	5.0	Close pulse width; when it is 0, it means constant output.
2	Open Time	(0~20.0)s	3.0	Open pulse width.
Module Setting				
1	Power On Mode	(0~2)	0	0: Stop mode 1: Manual mode 2: Auto mode
2	Module Address	(1~254)	1	Controller address at remote monitoring;
3	Stop Bit	(0~1)	0	0: 2 stop bits; 1: 1 stop bit
4	Language	(0~2)	0	0: Simplified Chinese 1: English 2: Others
5	Password	(0~65535)	00318	For entering parameter setting
6	Non-parallel Mode Enable	(0~1)	0	0: Disable; 1: Enable
7	Date and Time			Set current date and time.
8	Ethernet Enable	(0~1)	1	0: Disable; 1: Enable All Ethernet setting changes (e.g. IP address, subnet mask) are active after controller re-power on.
Scheduling and Maintenance Setting				
1	Scheduled Run	(0~1)	0	0: Disable; 1: Enable
2	Scheduled Not Run	(0~1)	0	0: Disable; 1: Enable
3	Maintenance	(0~1)	0	0: Disable; 1: Enable
Digital Input Ports Setting				
Digital Input Port 1				
1	Contents Setting	(0~55)	31	Remote Start On Load (on demand).
2	Active Type	(0~1)	0	0: Close; 1: Open
Digital Input Port 2				
1	Contents Setting	(0~55)	0	User Defined.
2	Active Type	(0~1)	0	0: Close; 1: Open
3	Active Range	(0~2)	2	0: Active in parallel running 1: Always active 2: Never
4	Active Action	(0~3)	3	0: Warn



No.	Items	Range	Defaults	Description
				1: Trip and Stop 2: Trip 3: Indication
5	Delay	(0~20.0)s	2.0	Time from input port is detected active to confirm.
6	Description			When input port is active, LCD will display the content.
Digital Input Port 3				
1	Contents Setting	(0~55)	0	High Temperature Shutdown.
2	Active Type	(0~1)	0	0: Close; 1: Open
3	Active Range	(0~2)	2	0: Active in parallel running 1: Always active 2: Never
4	Active Action	(0~3)	3	0: Warn 1: Trip and Stop 2: Trip 3: Indication
5	Delay	(0~20.0)s	2.0	Time from input port is detected active to confirm.
6	Description			When input port is active, LCD will display the content.
Digital Input Port 4				
1	Contents Setting	(0~55)	13	Gen Closed Aux.
2	Active Type	(0~1)	0	0: Close; 1: Open
Digital Input Port 5				
1	Contents Setting	(0~55)	0	User Defined.
2	Active Type	(0~1)	0	0: Close; 1: Open
3	Active Range	(0~2)	2	0: Active in parallel running 1: Always active 2: Never
4	Active Actions	(0~3)	3	0: Warn 1: Trip and Stop 2: Trip 3: Indication
5	Delay	(0~20.0)s	2.0	Time from input port is detected active to confirm.
6	Description			When input port is active, LCD will display the content.
Digital Input Port 6				
1	Contents Setting	(0~55)	0	User Defined.
2	Active Type	(0~1)	0	0: Close; 1: Open
3	Active Range	(0~2)	2	0: Active in parallel running



No.	Items	Range	Defaults	Description
				1: Always active 2: Never
4	Active Actions	(0~3)	3	0: Warn 1: Trip and Stop 2: Trip 3: Indication
5	Delay	(0~20.0)s	2.0	Time from input port is detected active to confirm.
6	Description			When input port is active, LCD will display the content.
Digital Input Port 7				
1	Contents Setting	(0~55)	0	User Defined.
2	Active Type	(0~1)	0	0: Close; 1: Open
3	Active Range	(0~2)	2	0: Active in parallel running 1: Always active 2: Never
4	Active Actions	(0~3)	3	0: Warn 1: Trip and Stop 2: Trip 3: Indication
5	Active Delay	(0~20.0)s	2.0	Time from input port is detected active to confirm.
6	Description			When input port is active, LCD will display the content.
Digital Input Port 8				
1	Contents Setting	(0~55)	15	Mains Closed Aux.
2	Active Type	(0~1)	0	0: Close; 1: Open
Relay Output Ports Setting				
Relay Output Port 1				
1	Contents Setting	(0~239)	44	Generator Normal Output.
2	Output Type	(0~1)	0	0: Normally open; 1: Normally close
Relay Output Port 2				
1	Contents Setting	(0~239)	48	Common Alarm.
2	Output Type	(0~1)	0	0: Normally open; 1: Normally close
Relay Output Port 3				
1	Contents Setting	(0~239)	46	Mains Normal Output.
2	Output Type	(0~1)	0	0: Normally open; 1: Normally close
Relay Output Port 4				
1	Contents Setting	(0~239)	47	Synchronizing.
2	Output Type	(0~1)	0	0: Normally open; 1: Normally close
Relay Output Port 5				
1	Contents Setting	(0~239)	31	Mains Close Output.



No.	Items	Range	Defaults	Description
2	Output Type	(0~1)	0	0: Normally open; 1: Normally close
Relay Output Port 6				
1	Contents Setting	(0~239)	29	Bus Close Output.
2	Output Type	(0~1)	0	0: Normally open; 1: Normally close
Relay Output Port 7				
1	Contents Setting	(0~239)	32	Mains Open Output.
2	Output Type	(0~1)	0	0: Normally open; 1: Normally close
Relay Output Port 8				
1	Contents Setting	(0~239)	30	Bus Open Output.
2	Output Type	(0~1)	0	0: Normally open; 1: Normally close
Sync Setting - Basic				
1	Dead Bus Volt	(10~50)V	30	It is considered bus is dead when bus voltage is lower than dead bus voltage.
2	Voltage Difference	(0~30)V	3	It is considered voltage synchronization when the voltage difference between generator and bus is lower than synchronization voltage difference.
3	Positive Freq Difference	(0~2.0)Hz	0.2	It is considered frequency synchronization when the frequency difference between generator and bus is less than positive difference but above negative difference.
4	Negative Freq Difference	(0~2.0)Hz	0.1	
5	Phase Angle Difference	(0~20)°	10	It is considered phase synchronization when the initial phase difference between gen and bus is lower than synchronizing phase angle difference.
6	Difference Frequency	(0~1.00)Hz	0.10	Frequency difference of adjusting gen frequency to be above mains freq.
7	MSC ID	(0~31)	1	ID indication of MSC communication network, MSC ID shall be unique in the whole communication network.
8	MSC Priority	(0~31)	0	Smaller the number is, higher the priority is.
9	Baud Rate	(0~3)	1	0: 500 kBit/s; 1: 250 kBit/s; 2: 125 kBit/s; 3: 50 kBit/s.
10	MSC Modules	(1~32)	2	
11	MSC Too Few Modules Action	(0~2)	1	Action: 0: None 1: Warn 2: Trip
12	Load Mode Control	(0~2)	0	0: Bus Control Mode 1: Mains Control Mode



No.	Items	Range	Defaults	Description
				2: Load Reception Mode
13	Output Active Power	(-100~100.0)%	30.0	Used for load control.
14	Reactive Control	(0~1)	0	0: Reactive power control 1: Power factor control
15	Reactive Control Amplitude	(0~100.0)%	8.0	Used for load control.
16	MSC Modules	(0~32)	1	If least started genset number is not detected during the delay, it will issue alarm based on pre-set alarm action. Action 0: None 1: Warn 2: Trip
17	MSC Too Few Modules Action	(0~2)	1	
18	Start Request Delay	(0~3600)s	120	
19	Fail to Sync Delay	(5.0~300.0)s	60.0	If sync signal is not detected during the delay, it will it will issue alarm based on pre-set alarm action. Action 0: Warn 1: Trip
20	Fail to Sync Action	(0~1)	0	
21	Sync Control Gain	(0~500)%	20	Regulate and control before parallel.
22	Sync Control Stab.	(0~2000)%	20	Regulate and control before parallel.
23	Active Power Control Gain	(0~500)%	20	Regulate and control after parallel.
24	Active Power Control Stability	(0~2000)%	20	Regulate and control after parallel.
25	Sync Control Gain	(0~500)%	20	Regulate and control before parallel.
26	Sync Control Stability	(0~2000)%	20	Regulate and control before parallel.
27	Reactive Power Control Gain	(0~500)%	20	Regulate and control after parallel.
28	Reactive Power Control Stability	(0~2000)%	20	Regulate and control after parallel.

8.2 DEFINABLE CONTENTS OF PROGRAMMABLE OUTPUTS

8.2.1 DEFINABLE CONTENTS OF PROGRAMMABLE OUTPUTS

Table 14 Definable Contents of Programmable Output Ports

No.	Type	Description
0	Not Used	
1~6	Reserved	
7	Custom Combined 1	For details of function description please see the following contents.
8	Custom Combined 2	
9	Custom Combined 3	
10	Custom Combined 4	
11	Custom Combined 5	



No.	Type	Description
12	Custom Combined 6	
13~17	Reserved	
18	Audible Alarm	Act at warning, shutdown, and trips; Can connect an annunciator externally; When "alarm mute" configurable input port is active, it is prohibited to output.
19~25	Reserved	
26	Remote Control Output	This port is controlled by communication (PC).
27~28	Reserved	
29	Bus Close Output	Control bus to take load.
30	Bus Open Output	Control bus to unload.
31	Mains Close Output	Control mains to take load.
32	Mains Open Output	Control mains to unload.
33~43	Reserved	
44	Bus Normal Output	Act when bus voltage is normal.
45	Reserved	
46	Mains Normal Output	
47	Synchronizing	
48	Common Alarm	Act at genset common warning, common shutdown, common trip alarms.
49	Common Trip and Stop	Act at common trip and stop alarms.
50	Common Shutdown	Act at common shutdown alarms.
51	Common Trip	Act at common trip alarms without stop.
52	Common Warning	Act at common warning alarms.
53	Reserved	
54	Battery Over Voltage	Act at battery's over voltage warning alarms.
55	Battery Under Voltage	Act at battery's low voltage warning alarms.
56~68	Reserved	
69	Digital Input 1 Active	Act when input port 1 is active.
70	Digital Input 2 Active	Act when input port 2 is active.
71	Digital Input 3 Active	Act when input port 3 is active.
72	Digital Input 4 Active	Act when input port 4 is active.
73	Digital Input 5 Active	Act when input port 5 is active.
74	Digital Input 6 Active	Act when input port 6 is active.
75	Digital Input 7 Active	Act when input port 7 is active.
76	Digital Input 8 Active	Act when input port 8 is active.
77~124	Reserved	
125	Mains Inactive	
126	Mains Over Frequency	
127	Mains Over Voltage	
128	Mains Under Frequency	
129	Mains Under Voltage	
130	Mains Phase Sequence	



No.	Type	Description
	Wrong	
131	Mains Loss of Phase	
132~229	Reserved	
230	In Stop Mode	Act when system in Stop mode.
231	In Manual Mode	Act when system in Manual mode.
232	Reserved	
233	In Auto Mode	Act when system in Auto mode.
234	Bus Load Indicator	
235	Mains Load Indicator	
236~239	Reserved	

SmartGen

8.2.2 DEFINED COMBINATION OUTPUT

Defined combination output is composed by 3 parts: OR condition output S1, OR condition output S2, AND condition output S3.

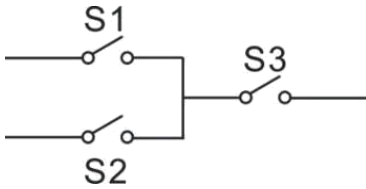

S1 or S2 is **TRUE**, and S3 is **TRUE**, defined combination output is outputting;

S1 and S2 are **FALSE**, or S3 is **FALSE**, defined combination output is not outputting.

▲NOTE: S1, S2, S3 can be set as any contents except for “defined combination output” in the output settings.

▲NOTE: 3 parts of defined combination output (S1, S2, S3) couldn't include or recursively include themselves.

For example:

Contents of OR condition output S1: Input port 1 is active;

Close when OR condition output S1 is active/inactive: close when active (disconnect when inactive);

Contents of OR condition output S2, input port 2 is active;

Close when OR condition output S2 is active/inactive: close when active (disconnect when inactive);

Contents of AND condition output S3: Input port 3 is active;



Close when AND condition output S3 is active/inactive: close when active (disconnect when inactive);

When input port 1 active or input port 2 is active, if input port 3 is active, defined combination output is outputting; If input port 3 is inactive, defined combination output is not outputting;

When input port 1 is inactive and input port 2 is inactive, whatever input port 3 is active or not, defined combination output is not outputting.

8.3 DEFINABLE CONTENTS OF PROGRAMMABLE INPUTS (GROUND CONNECTED (B-) ACTIVE)

Table 15 Definable Contents of Programmable Input Ports

No.	Type	Description
0	Users Defined	Users can define the following: Indication: indicate only, not warning or shutdown. Warning: warn only, not shutdown. Trip and stop: alarm, generator unload and shutdown Trip: alarm, generator unload but not shutdown. Never: input is inactive. Always: input is active all the time. Parallel running active: detected in the period of parallel running.
1	Reserved	
2	Alarm Mute	It can prohibit "Audible Alarm" output when it is active.
3	Alarm Reset	It can reset shutdown alarm and trip alarm when it is active.
4	Reserved	
5	Lamp Test	All LED indicators are illuminated when input is active.
6	Panel Lock	All buttons in panel are inactive except  and there is  on the right of first row in LCD Status screen when input is active.
7~8		
9	Auto Stop Inhibit	In Auto mode, during generator normal running, when input is active, generator automatically shuts down is prohibited.
10	Auto Start Inhibit	In Auto mode, generator automatically start is prohibited when input is active.
11	Scheduled Run Inhibit	In Auto mode, scheduled start genset is prohibited when input is active.
12	Reserved	
13	Bus Closed Aux	Connects aux. point of bus loading switch.
14	Bus Load Inhibit	Bus close is inhibited when input is active.
15	Mains Closed Aux	Connects aux. point of mains loading switch.
16	Mains Load Inhibit	Mains close is inhibited when input is active.
17	Auto Mode Input	When input is active, controller enters Auto mode; mode keys on the panel are inactive.
18	Auto Mode Inhibit	When input is active, controller won't work under Auto mode and simulate and auto keys does not work.
19~20	Reserved	
21	Alarm Stop Inhibit	All shutdown alarms are prohibited except emergence stop.
22	Instrument Mode	All outputs are prohibited in this mode.
23	Non-parallel Mode	
24	Reset Maintenance Time	Controller will set maintenance time and date as default when input is active.



No.	Type	Description
25~27	Reserved	
28	Remote Start (On Load)	In Auto mode, when input is active, genset can start and take load after genset running normal; when input is inactive, genset will stop automatically.
29	Remote Start (Off Load)	In Auto mode, when input is active, genset can start and take off load after genset running normal; when input is inactive, genset will stop automatically.
30	Manual Start Aux	In Manual mode, when input is active, genset will start automatically; when input is inactive, genset will stop automatically.
31	Remote Start (On Demand)	In Auto mode, when input is active, genset will start/stop according to load.
32	Remote Start (Island)	In Auto mode, when input is active, genset will start automatically and take load after normal running, mains unloads; when input is inactive, mains takes load and genset unloads and stops automatically.
33	Simulate Stop Button	An external button can be connected and pressed as the simulate panel key.
34	Simulate Manual Button	
35	Reserved	
36	Simulate Auto Button	An external button can be connected and pressed as the simulate panel key.
37	Simulate Start Button	
38	Simulate Bus Close/Open Button	
39	Simulate Mains Close/Open Button	
40	10s Mains Detection	
41~44	Reserved	
45	Simulate Mains Normal	In Auto mode, when input is active, it means mains is normal.
46	Simulate Mains Abnormal	In Auto mode, when input is active, it means mains is abnormal.
47~55	Reserved	

9 PARAMETER SETTING

⚠CAUTION! Please change controller parameters when generator is in standby mode (e.g. configurable input, configurable output, various delay etc.), otherwise shutdown alarm or other abnormal phenomenon may occur.

⚠NOTES:

- Maximum value must be over minimum set value in case that too high and too low may happen at the same time;
- When warning alarm is being set, please set the correct return value; otherwise it may cause abnormal alarms. When maximum value is being set, return value shall be less than the set value; when minimum value is being set, return value must be over set value;
- Configurable inputs could not be set the same item; otherwise, there may be abnormal functions. However, configurable outputs can be set to the same item.

10 COMMISSIONING

- 1) Conduct start, stop and load performance tests on every genset;
- 2) Parallel every genset with busbar, and do breaker close/open tests;
- 3) Set every genset (e.g. HGM8151) to Auto Mode;
- 4) Set HGM8156 in Manual Mode, and make Mains working well, to test whether mains close/open are normal; when they are normal, open mains breaker;
- 5) Start HGM8156 manually, after busbar goes normal, test whether busbar close/open are normal; after they are normal, close mains breaker;
- 6) Press mains close button, and busbar synchronizes mains; after synchronization mains breaker closes and starts running in parallel;
- 7) Conduct load tests and load transfer tests;
- 8) Set HGM8156 controller to Auto Mode, and controller will start/stop automatically based on settings and conditions.

11 MAINS PARALLEL MODE

11.1 BUS CONTROL MODE

Output pre-set active power, reactive power and power factor.

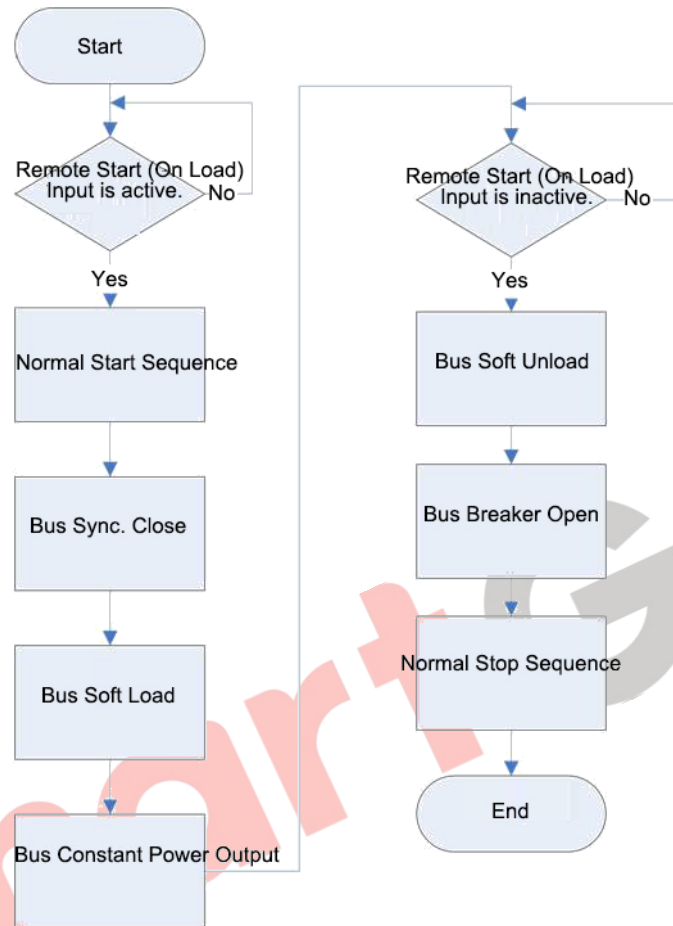

Fig. 2 Constant Power Output Mode

11.2 MAINS CONTROL MODE

If pre-set value of output power is positive, bus outputs active power and reactive power over pre-set mains power. Mains output power is not more than the pre-set output power value (Mains Peak Clipping Mode).

If pre-set value of output power is negative, bus outputs pre-set active power and reactive power to mains; Total power of bus output is the sum of load consumption power and set value of mains output power.

Mains Peak Clipping Mode:

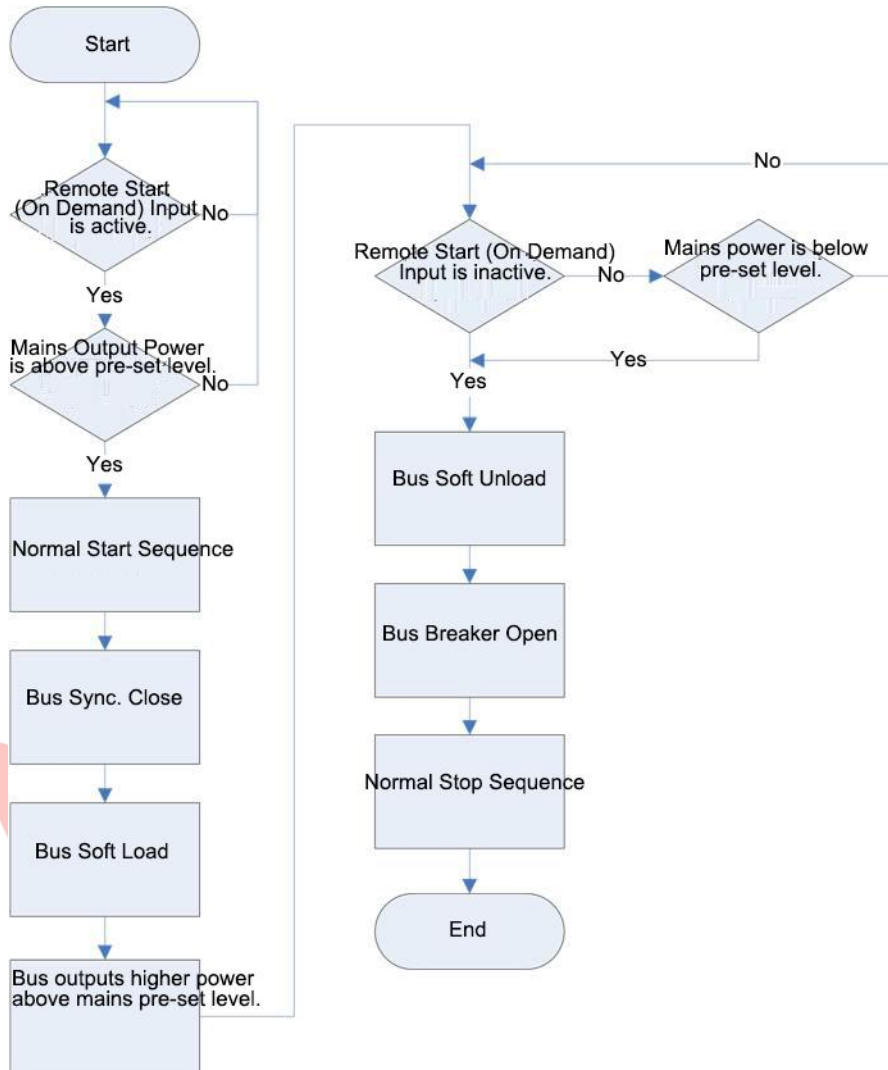

Fig. 3 Mains Peak Clipping Mode

11.3 LOAD RECEPTION MODE

Load Reception Mode

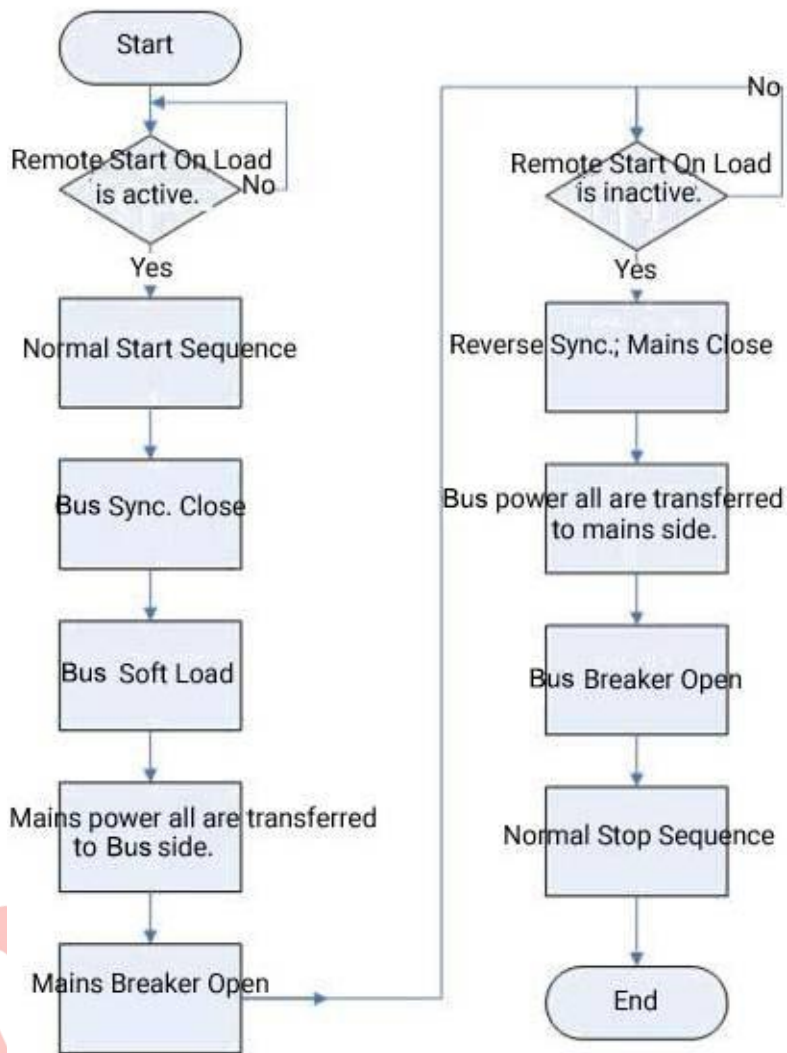

Fig. 4 Load Reception Mode

11.4 AMF CONTROL MODE

Automatic mains failure start mode.

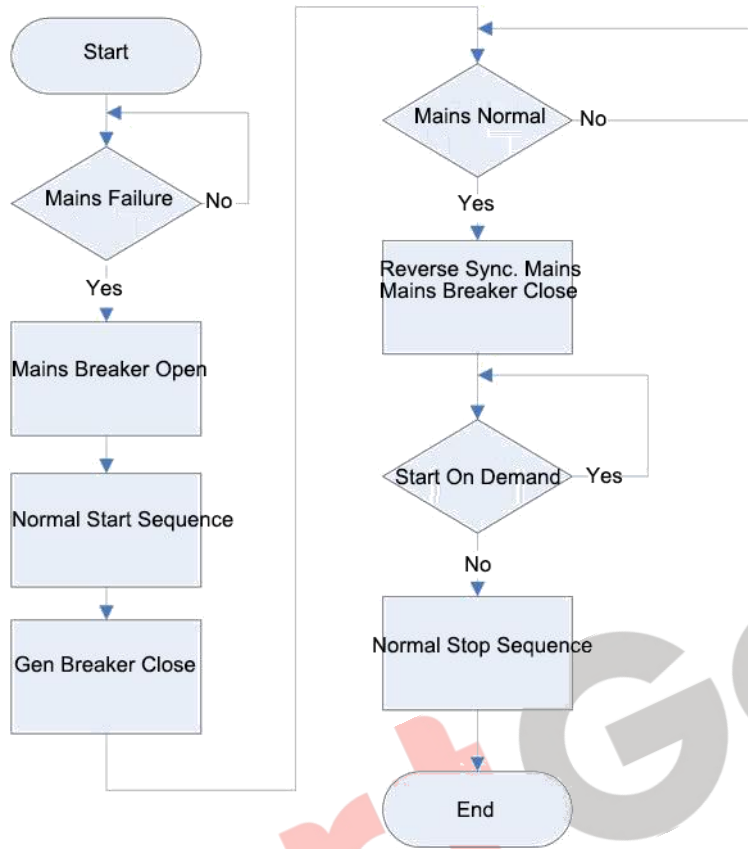

Fig. 5 AMF Mode

11.5 ISLAND START MODE

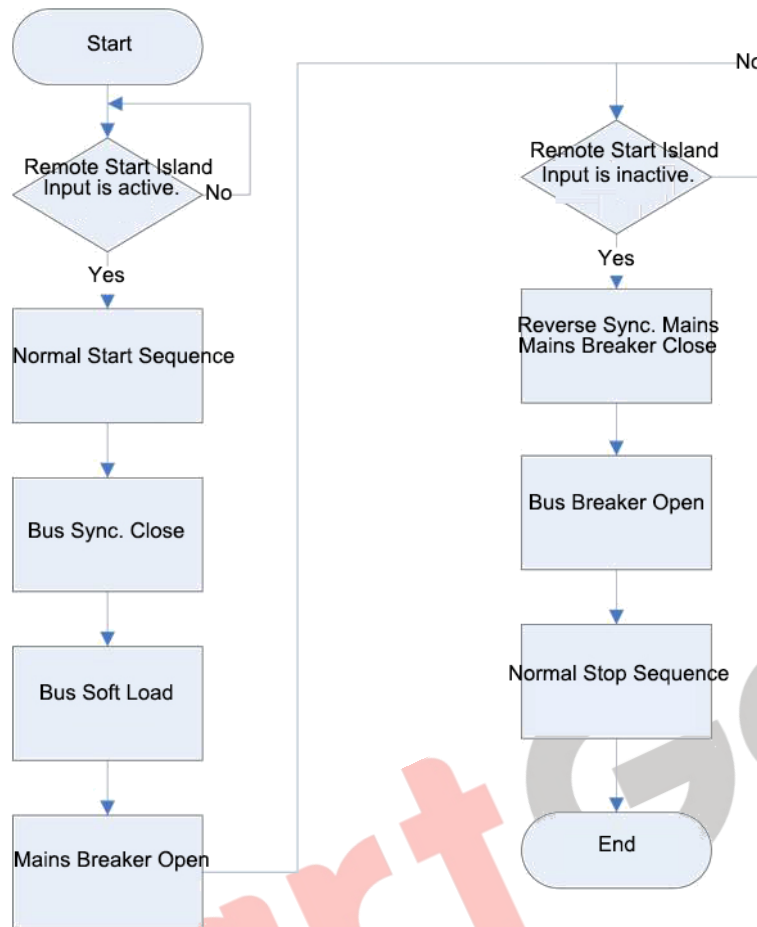

Fig. 6 Island Output Mode

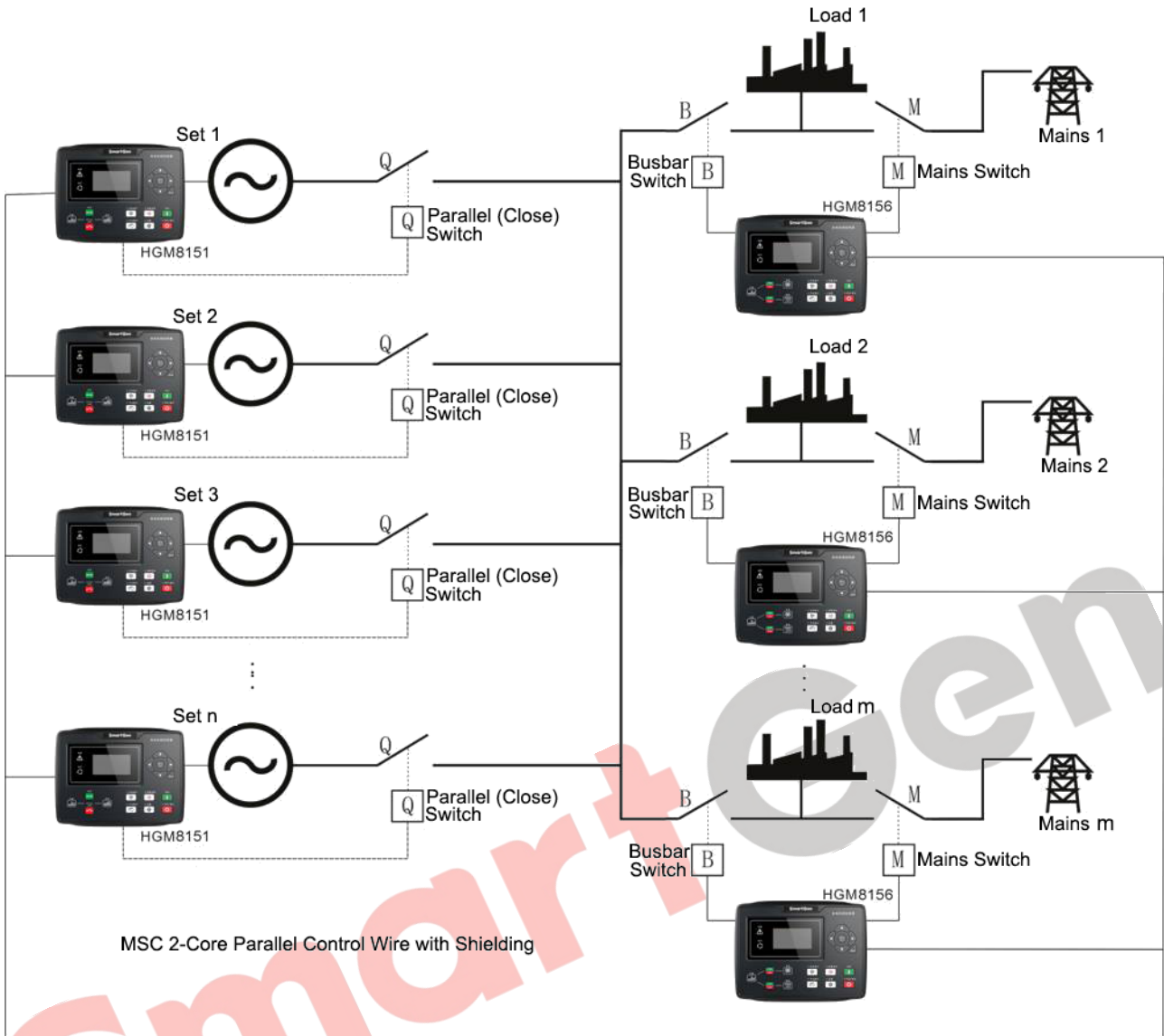

Fig. 9 N-way Load Application Diagram

NOTE: When N-way load is applied, CT on the bus shall be connected.

13 INSTALLATION

Controller is panel built-in design and it is fixed by clips when installed. The controller overall dimensions and cutout size are as below:

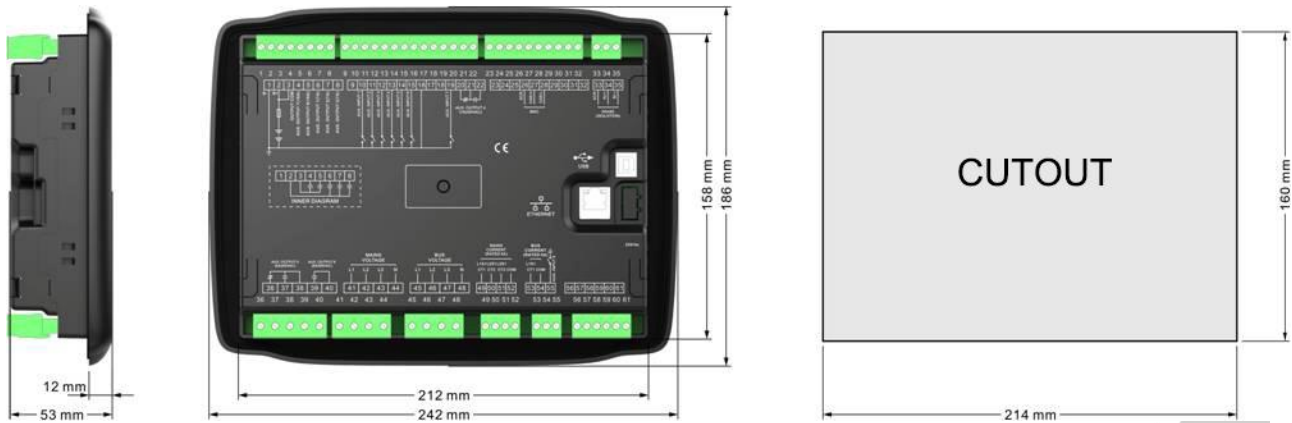

Fig. 10 Case Dimensions and Cutout

13.1 BATTERY VOLTAGE INPUT

HGM8156 controller suits wide range battery voltage (8~35)VDC. Negative of battery must be connected with the shell of starter. The wire diameter of connecting B+ and B- with battery negative and positive must not be less than 2.5mm². If floating charger is installed, please firstly connect output wires of charger to battery's positive and negative directly, then connect wires from battery's positive and negative to controller power input terminals in order to prevent charger disturbing the controller's normal working.

13.2 OUTPUT AND EXPAND RELAYS

CAUTION! All outputs of controller are relay contact outputs. If it needs to expand relays, please add freewheel diode to both ends of expansion relay coils (when coils of relay have DC current) or, increase resistance-capacitance return circuit (when coils of relay have AC current), in order to prevent disturbance to controller or other equipment.

13.3 AC INPUT

Current input must be connected to outside current transformer. Current transformer's secondary side current must be 5A. At the same time, phases of current transformer and input voltage must be correct, otherwise collected current and active power may not be correct.

NOTE: ICOM port must be connected to negative of battery.

WARNING! When there is load current, transformer's secondary side is prohibited to open circuit.

13.4 WITHSTAND VOLTAGE TEST

CAUTION! When controller has been installed in control panel, if high voltage test is needed, please disconnect controller's all terminal connections, in order to prevent high voltage entering controller and damaging it.

14 ETHERNET PORT

14.1 ILLUSTRATION

Ethernet port can be used to monitor controller and realize network client connection.

NOTE: After changing network parameters of controller (e.g. IP address, subnet mask etc.), controller shall be powered on again to make new settings effective.

14.2 NETWORK CLIENT CONNECTION

As network client, controller can be monitored by TCP Modbus protocol via network port.

Steps are as below:

- Set IP address and sub network mask of the controller. IP address must be in the same network segment with monitoring equipment (e.g. PC), but is different from it; e.g.: if monitoring equipment IP address is 192.168.0.16, controller IP can be 192.168.0.18, subnet mask is 255.255.255.0.
- Connect the controller. It can be connected to the monitoring equipment directly using network cable or via switchboard.
- The communication between the controller and monitoring equipment is carried out by TCP ModBus protocol.

NOTE: In this connection mode controller parameters can be set. SmartGen provides testing software for this connection mode. Communication protocol can be obtained from the SmartGen service.

14.3 CONTROLLER AND NETWORK CABLE CONNECTION

Table 16 Controller Internet Access

No.	Name	Description
1	TX+	Tranceive Data+
2	TX-	Tranceive Data-
3	RX+	Receive Data+
4	NC	Not connected
5	NC	Not connected
6	RX-	Receive Data-
7	NC	Not connected
8	NC	Not connected

14.3.1 CONTROLLER AND PC CONNECTION VIA A CABLE

For this connection crossover cable must be used.

Crossover cable: EIA/TIA 568A standard on one end and EIA/TIA 568B on the other end.

NOTE: If PC network port has Auto MDI/MDIX function, parallel cable can also be used.

14.3.2 CONTROLLER AND PC CONNECTION VIA SWITCHBOARD (OR ROUTER)

Parallel lines must be used.

Parallel cable: EIA/TIA 568A standard on both ends or EIA/TIA 568B standard on both ends.

NOTE: If switchboard (or router) network port has Auto MDI/MDIX function, crossover cable can also be used.

Table 17 Fault Finding

Symptoms	Possible Solutions
Controller no response with power	Check starting batteries; Check controller connection wirings; Check DC fuse.
Shutdown alarm in running	Check related switch and its connections according to the information on LCD; Check programmable inputs.
Genset running while ATS not transfer	Check ATS; Check the connections between ATS and controllers.
RS485 communication is abnormal	Check connections; Check setting of COM port is correct or not; Check if RS485's connections of A and B is reversely connected; Check RS485 transfer module is damaged or not; Check communication port of PC is damaged or not.