

# SmartGen

MAKING CONTROL SMARTER

## MGC100 PETROL GENSET CONTROLLER USER MANUAL



郑州众智科技股份有限公司  
SMARTGEN(ZHENGZHOU)TECHNOLOGY CO.,LTD.

## CONTENT

1 OVERVIEW .....	5
2 PERFORMANCE AND CHARACTERS .....	5
3 SPECIFICATION .....	6
4 OPERATION .....	7
4.1 PUSHBUTTONS .....	7
4.2 CONTROLLER PANEL AND ICON DESCRIPTION .....	7
4.2.1 CONTROLLER PANEL .....	7
4.2.2 ALARM ICON INDICATION .....	8
4.2.3 PANEL INDICATOR .....	8
4.3 OPERATION .....	8
4.3.1 REMOTE START SEQUENCE .....	8
4.3.2 REMOTE STOP SEQUENCE .....	8
4.3.3 MANUAL START/STOP .....	9
5 PROTECTION .....	9
6 CONNECTION .....	10
7 DEFINITION AND RANGE OF PARAMETERS .....	11
8 PARAMETERS SETTING .....	14
8.1 PARAMETERS REGULATION .....	14
8.2 RESTORE FACTORY SETTINGS .....	14
8.3 ELIMINATE ACCUMULATED TIME .....	14
9 CASE DIMENSIONS .....	15
10 TYPICAL APPLICATION .....	16
11 FAULT FINDING .....	16

## SmartGen Registered trademark

No. 28 Xuemei Street, Zhengzhou, Henan, China

Tel: +86-371-67988888/67981888/67992951

+86-371-67981000 (overseas)

Fax: +86-371-67992952

Web: [www.smartgen.com.cn/](http://www.smartgen.com.cn/)

[www.smartgen.cn/](http://www.smartgen.cn/)

Email: [sales@smartgen.cn](mailto:sales@smartgen.cn)



All rights reserved. No part of this publication may be reproduced in any material form (including photocopying or storing in any medium by electronic means or other) without the written permission of the copyright holder.

SmartGen reserves the right to change the contents of this document without prior notice.

**Table 1 Version History**

Date	Version	Content
2015-06-29	1.0	Original release.
2016-12-12	1.1	1. Modify AC default, over speed threshold, crank disconnect conditions, crank disconnect speed, safety running delay and programmable outputs default ; 2. Add gen under/over frequency protection functions; 3. Add gen under/over frequency threshold and under/over frequency shutdown delay parameter. 4. Programmable output ports add "Air Flap Choke" function
2022-07-22	1.2	Update company logo and manual format.
2023-09-26	1.3	1. Modify the default value of start delay to be consistent with upper and lower computer; 2. Modify company address information.

**Table 2 Notation Clarification**

Sign	Instruction
 NOTE	Highlights an essential element of a procedure to ensure correctness.
 CAUTION!	Indicates a procedure or practice, which, if not strictly observed, could result in damage or destruction of equipment.
 WARNING!	Indicates a procedure or practice, which could result in injury to personnel or loss of life if not followed correctly.

SmartGen

## 1 OVERVIEW

**MGC100 Petrol Genset Controller** is designed for start and protection of single genset. It allows manual and remote start/stop, data measurement, alarm indication, shutdown protection functions. The controller fit with LED display, button-press operation, and it achieves precise measurement of various parameters, protection and control of genset. All of parameters can be configured from front panel. The controller which can be widely used in data display and fault protection of a number of small diesel and petrol genset with easy operation, reliable work, compact structure and simple connections.

## 2 PERFORMANCE AND CHARACTERS

- Multifunctional Nixie tube display, press button to operate;  
Switchable displayed battery:
  - Generate voltage V
  - Generate frequency Hz
  - Accumulated running time (maximum is 9999h) H
  - Battery voltage V
- There is a red LED on the panel for displaying working and alarm status;
- Chose to control Petrol Genset or Diesel Genset via connection;
- Suitable for 3-phase 4-wire, 3-phase 3-wire, 2-phase 3-wire, single phase 2-wire (120V/240V) systems with frequency 50/60/Hz;
- Protection function for gen under/over volt, over speed, fail to stop, emergency stop, high water temp, low oil pressure; when in protection, LED indicates alarm, and goes shutdown protection;
- Generator rotate speed can derive from gen frequency or speed sensor;
- 4-way digital input (high water temperature input, low oil pressure input, remote input, urgency stop input);
- 2 relay output (start output, fuel output) and the fuel output is programmable output port;
- 1 flexible transistor output can be set to preheat output, alarm output, energize to stop output and idle output, etc;
- Three start success conditions (speed sensor, generator, speed sensor+ generator) can be chosen;
- Parameter setting: parameters can be modified and stored in internal EEPROM memory and cannot be lost even in case of power outage; all of them can be adjusted using front panel of the controller;
- Modular design, anti-flaming ABS plastic enclosure, embedded installation way; compact structure with easy mounting.

3 SPECIFICATION

Table 3 Technical Parameters

Item	Contents
Working Voltage	DC9.0V to 18.0V, continuous power supply (suitable for DC12V system)
Overall Consumption	Regular working:<1W (Standby mode:<0.4W)
AC Volt Input:	
3-phase 4-wire	AC 30V – AC 360V (ph-N)
3-phase 3-wire	AC 50V – AC 620V (ph-ph)
2-phase 3-wire	AC 30V – AC 360V (ph-N)
Single phase 2-wire	AC 30V – AC 360V (ph-N)
AC Frequency	50Hz/60Hz
Speed Sensor Voltage	1.0V to 24V(effective value)
Speed Sensor Frequency	10000Hz (Max)
Start Relay	7A DC12V power supply
Fuel Relay	7A DC12V power supply
Flexible Transistor	1A DC12V connect to (B+)
Overall Dimensions	105.8mm x 61mm x 36.6mm
Panel Cutout	92mm x 44mm
Working Temperature	(-25~+70)°C
Working Humidity	(20~93)%RH
Storage Temperature	(-25~+70)°C
Protection Level	IP55 Gasket
Insulation	Apply AC2.2kV voltage between high voltage terminal and low voltage terminal; The leakage current is not more than 3mA within 1min.
Weight	94g

## 4 OPERATION

### 4.1 PUSHBUTTONS

**Table 4 Keys Description**

Icon	Definition	Explain
	Stop/-	<p>Stop the running genset.</p> <p>In stop status, press it to stop generator immediately.</p> <p>In stop status, press it to reset any shutdown alarm.</p> <p>In stop status, press it for more than 2s to test if the nixie tube and panel indicator are normal.</p> <p>In setting menu, upturn or decrease parameter value (it can be double-clicked).</p> <p>In setting menu, press it for more than 3s to exit this menu.</p>
	Page/Confirm	<p>Switch display contents of nixie tube in normal status.</p> <p>Pressing it for more than 3 seconds entry the parameter configuration menu.</p> <p>In setting menu, press this button to modify and save value.</p>
	Run/+	<p>Manual start in stop status.</p> <p>In setting menu, downturn or increase parameter value (it can be double-clicked).</p>

### 4.2 CONTROLLER PANEL AND ICON DESCRIPTION







#### 4.2.1 CONTROLLER PANEL



**Fig.1 Controller Panel**

## 4.2.2 ALARM ICON INDICATION

**Table 5 Alarm Icon Indication**

Icon	Descripton	Icon	Descripton
	Emergency Stop Alarm		Over Speed Alarm
	High Temp Alarm		Low Oil Pressure Alarm
	Fail to Start Alarm		Over/Under Volt Alarm

## 4.2.3 PANEL INDICATOR

Working status indicator: in start delay duration, start indicator will blink; in other working duration, the indicator will always light; in stop status, the indicator will extinguish.

Stop status indicator: in stop process, stop indicator will blink; in stop duration, the indicator will always light; in start status, the indicator will extinguish.

## 4.3 OPERATION

### 4.3.1 REMOTE START SEQUENCE



- a) When remote start signal is active, "Start Delay" timer is initiated;
- b) When start delay is over, preheat relay energizes (if configured), "Preheat delay" is initiated;
- c) After the above delay, the Fuel Relay is energized, and then one second later (if configured), the Start Relay is engaged and the Preheat Relay switch off. If genset fails to fire during this cranking attempt then the fuel relay and start relay are disengaged for the pre-set rest period; "Crank Rest Time" begins and wait for the next crank attempt (after the "Crank Rest Time" delay start for 3s, preheat and ETS start to output; after "Crank Rest Time" finished, ETS switch off, and after fuel output for 1s, preheat switch off);
- d) Should this start sequence continue beyond the set number of attempts, the fail to start indicator will be illuminated;
- e) In case of successful crank attempt, the "Safety On" timer is activated, allowing Low Oil Pressure Input and Under Pressure are inhibited. As soon as this delay is over, "start idle" delay is initiated (if configured);
- f) During "Start Idle" delay, under pressure alarm is inhibited. When this delay is over, "Warming Up" delay is initiated (if configured);
- g) After the "Warming Up" delay, genset will enter into Normal Running status.

### 4.3.2 REMOTE STOP SEQUENCE

- a) After remote start, when remote start signal is invalid, "Stop Delay" timer is initiated;
- b) Once this "stop delay" has expired, the "Cooling Delay" is then initiated;
- c) During "Stop Idle" Delay (if configured), idle relay is energized;
- d) "ETS Solenoid Hold" begins, ETS relay is energized while fuel relay is de-energized;
- e) "Fail to Stop Delay" begins, complete stop is detected automatically;
- f) Genset is placed into standby mode after its "After Stop Time".



## 4.3.3 MANUAL START/STOP

- a) Press  to start genset. It will detect complete start and accelerate to high-speed running automatically. With high temperature, low oil pressure, over speed and volt abnormal during genset running, controller can protect it to stop quickly (Please refer to Start Sequence b-g).
- b) Press  to stop the running genset (Please refer to Stop Sequence b-f).

### NOTE:

- a) The genset can be stopped manually in remote start status; at this time, remote input is inhibited and it will be active when remote input is closed again.
- b) After start conditions are satisfied, accumulative running timer will be initiated; at the same time, the last blinking decimal of nixie tube indicates that genset works normally.

## 5 PROTECTION

- 1) Low Oil Pressure: detect after Safety On, Alarm Stop when Low Oil Pressure input is active and lasts for 2s.
- 2) High Temperature: detect when start, Alarm Stop when High Temperature is active and lasts for 2s.
- 3) Over Speed: detect when start, Alarm Stop after duration exceeds Over Speed Stop Delay.
- 4) Gen Over Volt: Alarm Stop when the controller detects genset voltage exceeds overvoltage value and delay exceeds abnormal delay.
- 5) Gen Under Volt: Alarm Stop when the controller detects genset voltage less than under voltage value and delay less than abnormal delay.
- 6) Emergency Stop: ETS output immediately when Emergency Stop is active, in the meanwhile fuel, preheat and start signal are cut off and Emergency Shutdown Alarm Signal is sent.
- 7) Fail to Start: Alarm Stop when start failed in preset start times.
- 8) Gen Under Frequency: When genset is normal running, controller detects gen frequency falls below under frequency value and the "under frequency" delay has expired, under frequency shutdown alarm will be sent.
- 9) Gen Over Frequency: Detection when start genset, if gen frequency exceeds over frequency value and the "over frequency" delay has expired, over frequency shutdown alarm will be sent.

6 CONNECTION

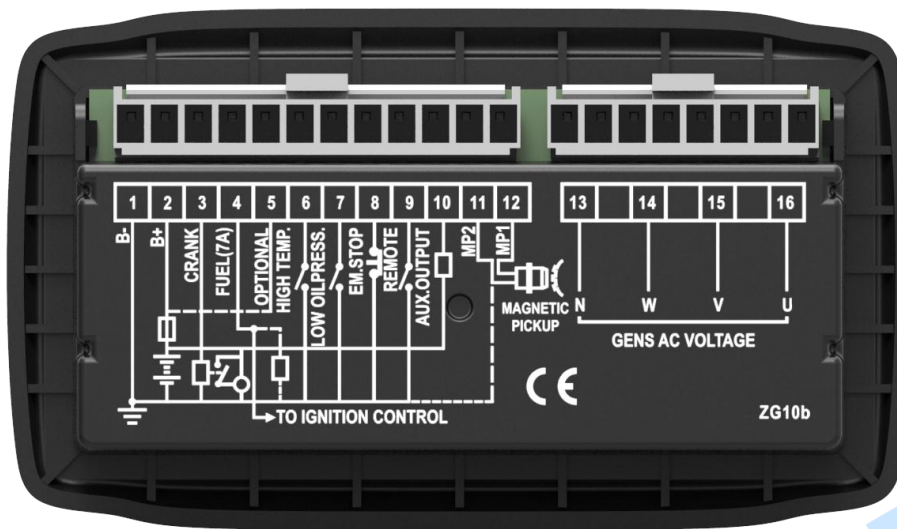

Fig.2 Rear Panel

Table 6 Terminal Connection Description

No.	Function	Cable Size	Note
1	B-	1.0mm <sup>2</sup>	Connected with negative of starter battery.
2	B+	1.0mm <sup>2</sup>	Connected with negative of starter battery. If wire length is over 30m, better to double wires in parallel. Max. 10A fuse is recommended.
3	Start Relay Output	1.0mm <sup>2</sup>	B+ power is supplied by terminal 2, rated 7A. Connected with start coil of starter.
4	Fuel Relay Output	1.0mm <sup>2</sup>	B+ power is supplied by terminal 2, rated 7A.
5	Controller Types	1.0mm <sup>2</sup>	When this terminal short connected with (B+), it used as diesel genset controller. When this terminal connected with nothing, it used as petrol genset controller.
6	High Temperature	1.0mm <sup>2</sup>	Ground connected is active (B-).
7	Low Oil Pressure	1.0mm <sup>2</sup>	Ground connected is active (B-).
8	Emergency Stop	1.0mm <sup>2</sup>	Ground connected is active (B-).
9	Remote Start	1.0mm <sup>2</sup>	Ground connected is active (B-).
10	Aux. Transistor	1.0mm <sup>2</sup>	B- power is supplied by terminal 1, rated 1A.
11	Magnetic Pickup 2 (B-) has already connected with controller innerly.	0.5mm <sup>2</sup>	Connected with Rotate Speed Sensor, shielding line is recommended.
12	Magnetic Pickup 1	0.5mm <sup>2</sup>	
13	N	1.0mm <sup>2</sup>	Connected with N wire.
14	W phase voltage monitor	1.0mm <sup>2</sup>	Connected with W phase (2A fuse is recommended).
15	V phase voltage monitor	1.0mm <sup>2</sup>	Connected with V phase (2A fuse is recommended).
16	U phase voltage monitor	1.0mm <sup>2</sup>	Connected with U phase (2A fuse is recommended).

7 DEFINITION AND RANGE OF PARAMETERS

Table 7 Parameter Content and Range

No.	Content	Parameter Range	Default	Description
P00	AC	(0-3)	0	0: Single phase 2-wire 1: 2-phase 3-wire 2: 3-phase 3-wire 3: 3-phase 4-wire
P01	Over Volt Threshold	(30-620)V	264	When generate voltage exceed this value and last for "Abnormal Delay", then it is regarded as over voltage and at the same time "Gen Abnormal" signal will be sent. When set value is 620V, it won't detect over voltage signal.
P02	Under Volt Threshold	(30-620)V	196	When generate voltage is under this value and last for "Abnormal Delay", then it is regarded as under voltage and at the same time "Gen Abnormal" signal will be sent. When set value is 30V, it won't detect under voltage signal.
P03	Gen Abnormal Delay	(0-20)s	10	Alarm delay value of generate over or under voltage.
P04	Start Delay	(0-360.0)min	0.2	Time from remote start signal is active to start the genset.
P05	Stop Delay	(0-3600)s	1	Time from remote stop signal is deactivated to stop the genset.
P06	Start Attempts	(1-10)times	3	It is maximum of start attempts when starter failed to start. When reach set attempts the fail to start alarm will be initiated.
P07	Preheat Delay	(0-300)s	0	Time of pre-powering heat plug before starter is powered up.
P08	Crank Time	(3-60)s	8	Time of starter power up.
P09	Crank Rest Time	(3-60)s	10	The waiting time before second power up when engine start fail.
P10	Safety On Time	(1-60)s	5	Alarms for low oil pressure and under voltage are inactive.
P11	Start Idle Time	(0-3600)s	0	Idle running time of genset when starting.
P12	Warming Up Time	(3-3600)s	10	Warming time between genset close and high speed running.
P13	Cooling Time	(3-3600)s	10	Radiating time before stop genset, after it unloads.
P14	Stop Idle Time	(0-3600)s	0	dle running time when pump unit stop.
P15	ETS Hold Time	(0-120)s	20	Stop electromagnet's power on time when pump unit is stopping.
P16	Stop Time	(0-120)s	0	Time between ending of pump unit idle delay and stopped when "ETS Time" is set as 0; Time between ending of ETS hold delay and

No.	Content	Parameter Range	Default	Description
				stopped when "ETS Time" is not 0.
P17	Flywheel Teeth	(10-300)	118	Teeth number of the engine, for judging of starter separation conditions and inspecting of engine speed. See the following Installation Instruction.
P18	Over Speed Threshold	(0-6000)r/min	3500	When rotate speed exceed this threshold and last over the delay value, over speed shutdown alarm signal will be sent. (No detection for over speed signals if it is set as 0).
P19	Over Speed Delay	(0-20)s	2	When rotate speed exceed over speed threshold and last over the delay value, over speed alarm signal will be sent.
P20	Poles	(2-16)	2	Set genset poles.
P21	Disc. Condition	(0-2)	1	Disconnected condition. Separate condition of starter and engine are gen sensor and magnetic sensor, in order that separate stater motor and engine as soon as possible.
P22	Disc. Speed	(0-6000)r/min	840	In starting process, if genset rotate speed exceed this value, it is regarded as genset start success, starter will separate.
P23	Disc. Freq	(10-30)Hz	14	In starting process, if genset frequency exceed this value, that is genset start success, starter will separate.
P24	Fuel Output Select	(0-1)	0	0: Fuel output; 1: Stop output (ETS Output).
P25	Aux. Output 1	(0-9)	5	Configuration see form "Aux. Output Defination"
P26	Gen Under Freq Threshold	(0-75.0)Hz	45.0	When gen frequency falls below this threshold and last over the delay value, under frequency shutdown alarm signal will be sent. (No detection for under frequency signals if it is set as 0).
P27	Under Freq Shutdown Delay	(0-60)s	10	Gen under frequency delay value.
P28	Gen Over Freq Threshold	(0-75.0)Hz	57.0	When gen frequency exceeds this threshold and last over the delay value, over frequency shutdown alarm signal will be sent. (No detection for over frequency signals if it is set as 0)
P29	Over Freq Shutdown Delay	(0-60)s	2	Gen over frequency delay value.
CLb1	Ua			Correct A phase voltage value.
CLb2	Ub			Correct B phase voltage value.
CLb3	Uc			Correct C phase voltage value.
CLb4	Uab			Correct AB wire voltage.

No.	Content	Parameter Range	Default	Description
CLb5	Ubc			Correct BC wire voltage.
CLb6	Uca			Correct CA wire voltage.

**Table 8 Defined Contents of Aux. Output Ports**

No.	Content	Description
0	Not Used	When this is chosen, output port won't output.
1	Preheat Output	Close before start, open before energize.
2	Common Alarm	When stop alarm is initiated, this alarm will self-lock until alarm reset.
3	Idle Output	Used for engine which has idles. Close before starting and open in warming up delay; Close during stopping idle process and open when stop is completed.
4	ETS Output	Used for some genset which has stop electromagnet. Close before stopping idle ended. Open when "ETS Delay" ended.
5	Air Flap Choke	Used for genset with choke valve electromagnet. Close when gen start and open when safety running delay is over.
6	Reserved	
7	Reserved	
8	Reserved	
9	Reserved	

**Table 9 Crank Disconnect Conditions Selection**



No.	Content
0	Magnetic Sensor
1	Generator
2	Magnetic Sensor + Generator







**NOTE:**

- 1) Magnetic sensor is magnetic device which detects numbers of flywheel teeth installed in generator.
- 2) If magnetic sensor is selected, please insure numbers of flywheel teeth is same with set value, otherwise, "Over Speed Shutdown" may be caused.
- 3) If genset without magnetic sensor, please don't select corresponding items, otherwise, "Start Failure" may be caused.
- 4) If generate isn't selected, the controller won't detect over/under voltage; if magnetic sensor isn't selected, speed of genset is converted via generate signal.

## 8 PARAMETERS SETTING

### 8.1 PARAMETERS REGULATION



When the controller is running, press  for 3s, it will enter into **parameter number menu** and LED will display :

- 1) Press  and  to downturn/upturn parameter number;
- 2) After parameter number is selected, press  to enter into parameter setting menu; press  and  to increase/decrease parameter value (it can be double-clicked);
- 3) Press  to confirm modification and save value;
- 4) For multiple parameters, step (1-3) can be repeat done for setting;
- 5) After parameter setting, press  for 3s to exit parameter setting status.

### 8.2 RESTORE FACTORY SETTINGS

In emergency stop input status, press  and  for 5s at the same time, it can restore to default and “reset” will be displayed on LED.

### 8.3 ELIMINATE ACCUMULATED TIME

Press  and  for 5s at the same time, accumulated running time will be reset an “hclr” will be displayed on LED.

#### NOTE:

- Over voltage threshold must be greater than under voltage threshold.
- When start successfully, generator frequency need to be set lower as soon as possible in order to starter separate sooner.
- Number of setting contents refers to “Parameter Content and Range (Table 7)”.
- Only in parameter number menu can exit from parameter setting status. If there is no press operation in parameter number menu, it will exit in 30s automatically.

## 9 CASE DIMENSIONS

Controller is panel built-in design; it is fixed by clips when installed.

Unit: mm

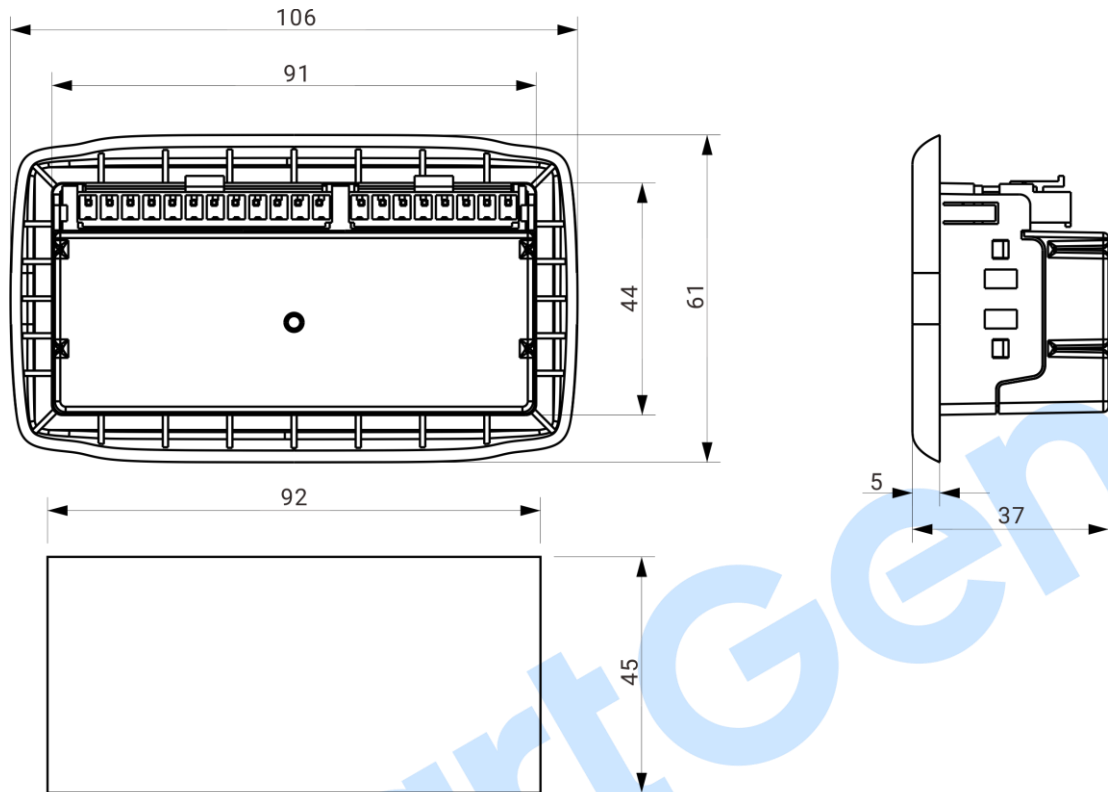

**Fig.3 Case Dimensions**

### 1) Battery Voltage Input

**NOTE:** MGC100 controller can suit for widely range of battery voltage DC(9~18)V. Negative of battery must be connected with the engine shell soundly. The diameter of wire which from power supply to battery must be over 1.0mm<sup>2</sup>. If floating charge configured, please firstly connect output wires of charger to battery's positive and negative directly, then, connect wires from battery's positive and negative to controller's corresponding input ports in order to prevent charge disturbing the controller's normal working.



**WARN:** In running process, removing start battery is strictly prohibit.

### 2) Speed Sensor Input

**NOTE:** Speed sensor is magnetic equipment which is installed on engine body for testing flywheel teeth number. 2 core shielding wire is used for the connection of the sensor and controller. The wire is supposed to be connected to 11 terminal of controller with one end and the other end hanging in the air. The other two signal lines connect separately to 11, 12 terminal. Speed sensor output voltage is supposed to be at AC (1-24)V (virtual value) when it is in full speed range, and AC12V (when in rated rotate speed) is recommended. When install the speed sensor, screw it to contact the flywheel firstly, inverse it with 1/3 circle, and then tighten the nut finally.

### 3) Withstand Voltage Test

**CAUTION:** When controller has been installed in control panel, if the high voltage test is needed, please disconnect controller's all terminals in order to prevent high voltage into controller and damage it.

10 TYPICAL APPLICATION

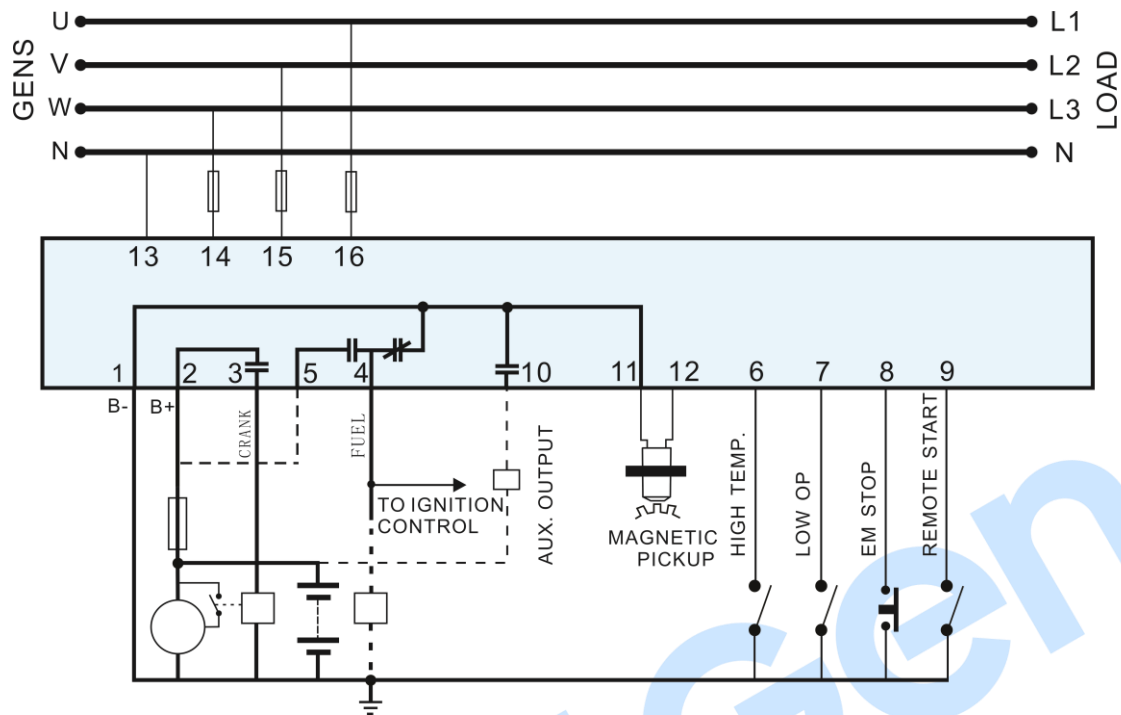

Fig.4 Typical Application

**NOTE:** When it controls petrol genset, terminal 4 connects with ignition control; when it controls diesel genset, terminal 5 needs to short connect with B+, terminal 4 needs to connect with fuel output.

11 FAULT FINDING

Table 10 Fault Finding

Symptoms	Possible Solutions
Controller no response with power	Check starting batteries; Check controller connection wirings; Check DC fuse.
Crank not disconnect	Check fuel oil circuit and its connections; Check starting batteries; Check speed sensor and its connections; Refer to engine manual.
Shutdown alarm in running	Check related switch and its connections according to the information on LED.
Starter no response	Check starter connections; Check starting batteries.