

SmartGen

MAKING CONTROL SMARTER

HAT660 SERIES

(HAT660B/HAT660BI/HAT660S)

ATS CONTROLLER

USER MANUAL

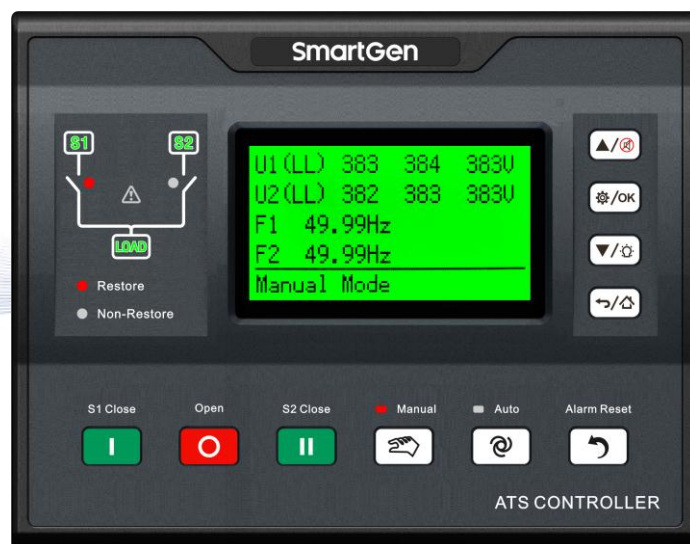

郑州众智科技股份有限公司
SMARTGEN(ZHENGZHOU)TECHNOLOGY CO.,LTD.

SmartGen Registered trademark

No.28 Xuemei Street, Zhengzhou, Henan, China

Tel: +86-371-67988888/67981888/67992951

+86-371-67981000(overseas)

Fax: +86-371-67992952

Email: sales@smartgen.cn

Web: www.smartgen.com.cn
www.smartgen.cn



All rights reserved. No part of this publication may be reproduced in any material form (including photocopying or storing in any medium by electronic means or other) without the written permission of the copyright holder.

SmartGen reserves the right to change the contents of this document without prior notice.

Table 1 – Software Version

Date	Version	Note
2022-12-24	1.0	Original release.

Table 2 – Symbol Illustration

Symbol	Instruction
 NOTE	Highlights an essential element of a procedure to ensure correctness.
 CAUTION	Indicates a procedure or practice, which, if not strictly observed, could result in damage or destruction of equipment.
 WARNING	Indicates a procedure or practice, which could result in injury to personnel or loss of life if not followed correctly.

SmartGen

CONTENT

1 OVERVIEW.....	6
2 NAMING CONVENTION AND MODEL COMPARISON	7
2.1 NAMING CONVENTION	7
2.2 MODEL COMPARISON	7
3 PERFORMANCE AND CHARACTERISTICS.....	8
4 SPECIFICATION	9
5 MEASURED AND DISPLAY DATA	11
6 OPERATING.....	12
6.1 OPERATION PANEL	12
6.2 KEY FUNCTION DESCRIPTION.....	13
7 LCD DISPLAY	14
7.1 MAIN SCREEN	14
7.2 STATUS DESCRIPTION	16
7.3 MAIN MENU INTERFACE	20
8 GENSET START/STOP OPERATION.....	20
8.1 START/STOP GENSET IN MANUAL MODE	20
8.1.1 START/STOP GENSET ON PANEL.....	20
8.1.2 REMOTE START/STOP GENSET	21
8.2 START/STOP GENSET IN AUTO MODE.....	21
8.2.1 START CONDITIONS	21
8.2.2 START/STOP OF TWO GENSETS.....	21
8.2.3 SCHEDULED GEN START.....	22
8.2.4 SCHEDULE NOT WORK.....	22
9 PARAMETER SETTINGS.....	23
9.1 ILLUSTRATION	23
9.2 PARAMETER CONFIGURATION LIST.....	23
9.3 DIGITAL INPUT PORT FUNCTION DESCRIPTION	31
9.4 DIGITAL OUTPUT PORT FUNCTION DESCRIPTION.....	34
9.5 DEFINED COMBINATION OUTPUT.....	36
9.6 Over Current Definite Time and Inverse Definite Time Settings	36
10 HISTORICAL RECORDS	37
11 BLACK BOX RECORDS	38
12 HARMONIC ANALYSIS.....	39
13 AUTO RESTORE TIME SETTING	39
14 SWITCH OPERATION	40
14.1 MANUAL SWITCH OPERATION	40
14.2 AUTOMATIC SWITCH OPERATION.....	40
14.2.1 AUTO TRANSFER AUTO RESTORE.....	40
14.2.2 AUTO TRANSFER NON RESTORE (MUTUAL BACKUP ACTIVE)	41
14.2.3 AUTO TRANSFER NON RESTORE (MUTUAL BACKUP INACTIVE).....	42
14.3 SYNCHRONIZING CLOSE	43
14.3.1 S1 SYNC CLOSE	44
14.3.2 S2 SYNC CLOSE	45
14.3.3 MANUAL SYNC CLOSE	45
14.3.4 AUTO SYNC CLOSE.....	45
14.4 LOCAL MODE RUNNING	46

15 ATS SUPPLY POWER.....	46
15.1 DC SUPPLY.....	46
15.2 AC SUPPLY.....	46
16 NEL CONTROL.....	47
16.1 ILLUSTRATION.....	47
16.2 AUTOMATIC OPERATION.....	47
16.3 MANUAL TRIP.....	47
17 COMMUNICATION CONFIGURATION.....	48
17.1 ILLUSTRATION.....	48
17.2 RS485 COMMUNICATION PORT.....	48
17.3 USB COMMUNICATION PORT.....	48
17.4 ETHERNET COMMUNICATION PORT.....	48
18 TERMINAL DESCRIPTION.....	49
18.1 CONTROLLER TERMINAL DESCRIPTION.....	49
18.2 CONTROLLER POWER SUPPLY DESCRIPTION.....	51
18.2.1 DC SUPPLY.....	51
18.2.2 AC SUPPLY.....	51
18.3 RS485 CONNECTION DESCRIPTION.....	52
19 TYPICAL APPLICATION WIRING DIAGRAM.....	53
20 INSTALLATION.....	59
21 FAULT FINDING.....	60

1 OVERVIEW

HAT660 Series Dual Power Synchronous ATS Controller is an intelligent dual-supply synchronous transfer module integrating programmable function, automatic measurement, LCD display, and digital communication. It combines digitalization, intelligence and networking. Automatic measurement and control reduces incorrect operation. It is an ideal option for dual power transfer.

HAT660 Series Dual Power Synchronous ATS Controller is made by microprocessor as its core, which can accurately detect 2-way-3-phase voltage, make accurate judgment and output passive control switch for occurred abnormal voltages (over/under voltage, loss of phase, over/under frequency). This controller is applicable for Mains-Mains, Mains-Gen, Gen-Gen power supply system and can be used for transfer switch of PC class, CB class, and CC class after full consideration on various ATS (Automatic Transfer System) applications; Meanwhile it realizes synchronous transfer of two power supplies. It has compact structure, advanced circuits, simple wiring and high reliability, and can be widely used in electric power, telecommunications, petroleum, coal, metallurgy, railways, municipal administration, intelligent building, electrical devices, automatic control and testing system etc.

SmartGen

2 NAMING CONVENTION AND MODEL COMPARISON

2.1 NAMING CONVENTION

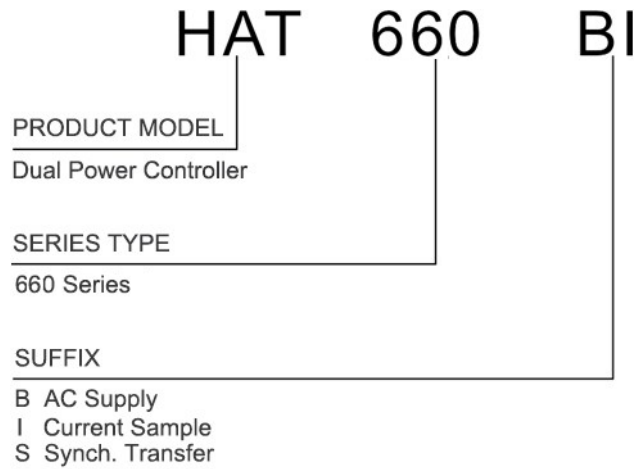

Fig. 1 – Naming Convention

2.2 MODEL COMPARISON

Table 3 – Model Comparison

Item	HAT660B	HAT660BI	HAT660S
DC Supply	•	•	•
AC Supply (LN90V~305V)	•	•	•
Current Monitor		•	•
Synch. Transfer			•
Input Port No. (Flexible)	7	7	7
Output Port No. (Fixed + Flexible)	1+7	1+7	1+7
Genset Control	•	•	•
RS485	•	•	•
USB	•	•	•
ETHERNET		•	•

NOTE 1: The fixed output port is LONO output.

3 PERFORMANCE AND CHARACTERISTICS

- LCD 132x64 pixel with backlight, multiple language display (Simplified Chinese, English, Other), push button operation;
- LED lamp can directly display current ATS close/open status, power status and whether load is power on;
- System type can be set to: Mains (1#) & Mains (2#), Mains (1#) & Generator (2#), Generator (1#) & Mains (2#), Generator (1#) & Generator (2#);
- S1 master, or S2 master can be set; Auto Transfer Auto Restore and Auto Transfer Non Restore are fitted for master power supply;
- Collect and display 2-way 3 phase Voltage, Frequency, and Phase Sequence Status;
- Collect and display load active power, reactive power, apparent power, power factor and current;
- Isolated sampling is applied;
- Independent overcurrent warning or trip alarm functions for S1/S2;
- NEL trip function is fitted;
- Display of S1/S2 accumulated active power, accumulated reactive power, accumulated close times is fitted;
- Each phase voltage of S1/S2, wave distortion rate of load current and 3-21 odd times harmonic percentage can be measured;
- Display of current power supply time and S1/S2 continuous power supply time is available;
- Automatic and manual synchronous transfer function is applicable, and the difference of voltage, frequency and phase of two circuits can be displayed;
- For energy storage switch, users can wait for and close the switch until PF (close is ready) signal is active;
- Over/under voltage, over/under frequency, loss of phase, reverse phase sequence monitoring functions are fitted;
- Auto/Manual transfer is fitted, so that breaker can be forced to close or open in manual mode;
- With local mode, the controller only displays data parameter when it is active and the switch needs to be transferred by external operations;
- Electrical interlock release function for switching in parallel (HAT660S only);
- All parameters can be configured on site; password is used to verify in case of non-professionals wrong operation;
- Custom start screen function is fitted;
- Commissioning can be done manually on site to conduct genset start/stop operations;
- Switch re-close and breakout re-close functions are fitted;
- Close output can be set to pulse or continuous output;
- Applicable for switches of PC class two-stage, PC class three-stage, CB class and CC class;
- Real time clock display, and event log function, which can record 200 data circularly;
- Black box function, which can record 5 items of events of ATS transfer, and 60 detailed data of 50s before each event record, and 10s after each event record;
- Scheduled run/not run function for genset, run for once, run monthly or weekly, and run on load or unload can also be set;
- Two gensets can be controlled and cycle run, master run, and balanced time run can be realized;
- Wide DC supply range, maximum 80V DC input for transient;
- Wide wire terminal space of AC input, maximum 528V voltage input;
- USB port, provides convenience for on-site debugging, and parameter or software upgrade;
- RS485 isolated communication port, making the controller has remote control, remote communication, remote measurement, remote adjustment functions by ModBus-RTU; it can remote control genset start/stop, ATS close and open;
- ETHERNET port, making the controller has remote control, remote communication, remote measurement, remote adjustment functions by ModBus TCP/IP; it can remote control genset start/stop, ATS close and open;
- Suitable for multiple AC system types (3P4W, 3P3W, 1P2W, 2P3W);
- Master and backup power supply can be set; ATS can normally work if one circuit is normal;
- Controller uses metal clips to fix;

- Modular design, flame retardant ABS plastic shell, pluggable terminal, built-in mounting, compact structure with easy installation.

4 SPECIFICATION

Table 4 – Performance Parameters

Items	Contents	
Operating Voltage	1. DC 8.0V~35.0V, continuous power supply; DC reverse connection protection; 2. AC power A1-N1/A2-N2 supply; voltage range AC (90~305)V.	
Power Consumption	<4W(Standby mode: <2W)	
AC Voltage Input (PT or PT Secondary is not used.)	AC system	HAT660B/HAT660BI/HAT660S
	3P4W (L-L)	(80~528)V
	3P3W (L-L)	N/A
	2P3W (A-B)	(80~528)V
	1P2W (L-N)	(50~305)V
	Voltage resolution: 1V; Accuracy: 0.5%	
AC Frequency	Rated: 50/60Hz Range: 15Hz~75Hz Resolution: 0.01Hz Accuracy: 0.1Hz	
AC Current	Rated: 5A Range: 0A~10A Resolution: 0.1A Accuracy: 2%	
Programmable Relay Output 1~2	16A AC250V Passive output	
Programmable Relay Output 3~4, 6~7	10A AC250V Passive output	
Programmable Relay Output 5	8A AC250V Passive output	
LONO Relay Output	12A AC250V Active output	
Digital Input 1~7	GND or (B-) active	
RS485 Port	Isolation, half-duplex, 2400/4800/9600/19200 baud rate can be set, Modbus-RTU communication protocol, the furthest communication distance 1000m	
ETHERNET Port	Self-adapting 10/100Mbps, Modbus TCP/IP communication protocol	
Design Standard	GB/T14048.11-2016 & IEC/EN 60947-6-1	
Production Compliance	According to EN 61010-1 installation category (over voltage category) III, 300V, pollution class 2, altitude 3000m	
Dimensions	198mmx154mmx54mm	
Panel Cutout	186mm x 141mm	
Operating Temperature	(-25~+70)°C	
Operating Humidity	(20~93)%RH	

Items	Contents
Storage Temperature	(-30~+80)°C
Protection Level	Front Panel: IP65, when waterproof gasket ring inserted between panel and housing; Back Panel: IP20;
Insulation Strength	Apply AC2.2kV voltage between high voltage terminal and low voltage terminal and the leakage current is not more than 3mA within 1min; Insulation resistance: 100MΩ
Weight	HAT660B/HAT660BI/HAT660S: 0.8kg

SmartGen

5 MEASURED AND DISPLAY DATA

Table 5 – Measured and Display Data Comparison

Measured/Display Data Item	HAT660B	HAT660BI	HAT660S
S1/S2 Power Phase Voltage	•	•	•
S1/S2 Power Line Voltage	•	•	•
S1/S2 Power Voltage Phase Sequence	•	•	•
S1/S2 Power Frequency	•	•	•
Load 3 Phase Current		•	•
Load 3 Phase Active Power kW		•	•
Load Total Active Power kW		•	•
Load 3 Phase Reactive Power kvar		•	•
Load Total Reactive Power kvar		•	•
Load 3 Phase Apparent Power kVA		•	•
Load Total Apparent Power kVA		•	•
Load 3 Phase Power Factor PF		•	•
Load Average Power Factor PF		•	•
Voltage Difference of S1 and S2			•
Frequency Difference of S1 and S2			•
Phase Difference of S1 and S2			•
Continuous Power Supply Time	•	•	•
Continuous Power Supply Time (Last Time)	•	•	•
S1 Accumulated Supply Time	•	•	•
S2 Accumulated Supply Time	•	•	•
S1 Accumulated Active Energy kWh		•	•
S2 Accumulated Active Energy kWh		•	•
S1 Accumulated Reactive Energy kvarh		•	•
S2 Accumulated Reactive Energy kvarh		•	•
S1 Accumulated Close Times	•	•	•
S2 Accumulated Close Times	•	•	•
Communication Status	•	•	•
Real Time Clock	•	•	•
Alarm Information	•	•	•
Event Log	•	•	•
Black Box Record	•	•	•
AC Voltage Wave Distortion Rate and 3-21 Times Harmonic Analysis	•	•	•
AC Current Wave Distortion Rate and 3-21 Times Harmonic Analysis		•	•

6 OPERATING

6.1 OPERATION PANEL

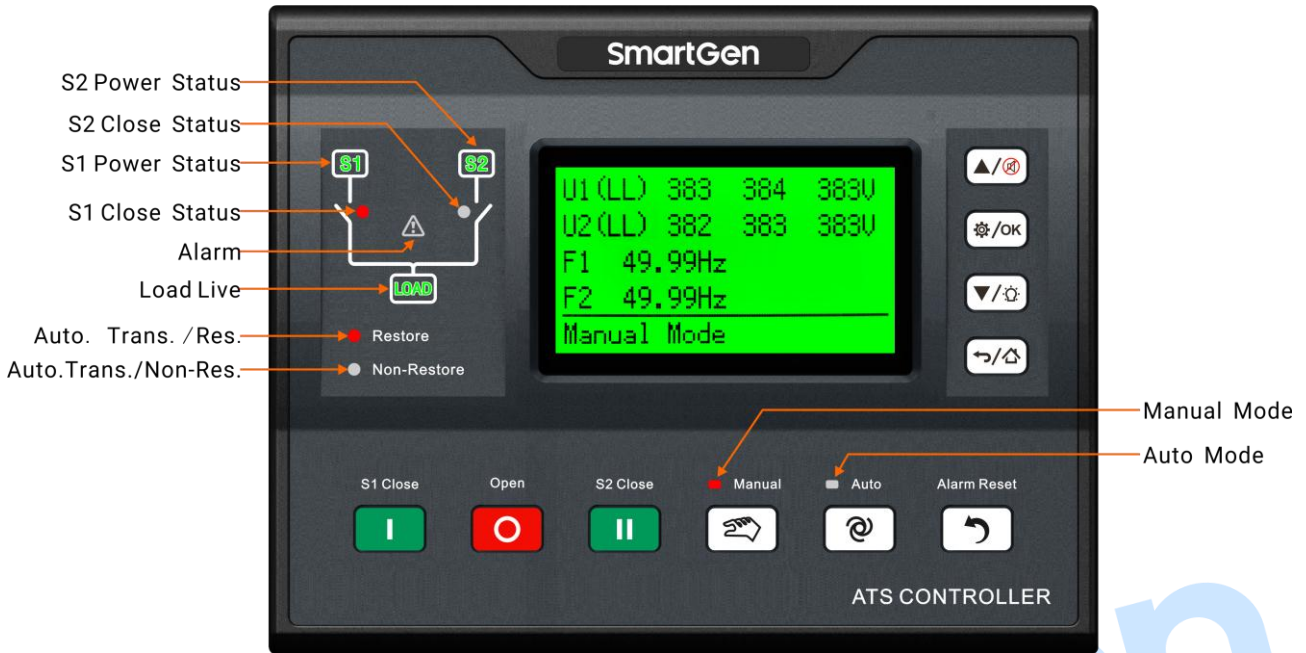











Fig. 2 – Front Panel

Table 6 – Indicator Description

Indicator	Indicator Description
S1 Power Status	Lamp On: S1 Power normal; Lamp Flashing: S1 Power abnormal (under/over voltage, under/over frequency, loss of phase, reverse phase sequence); Lamp Off: S1 Power none voltage;
S1 Close Status	Lamp On: S1 close auxiliary status input is active;
S2 Power Status	Lamp On: S2 Power normal; Lamp Flashing: S2 Power abnormal (under/over voltage, under/over frequency, loss of phase, reverse phase sequence); Lamp Off: S2 Power none voltage;
S2 Close Status	Lamp On: S2 close auxiliary status input is active;
Alarm	Lamp Slow Flashing: flashes when warning alarm occurs (1 time for 1 second); Lamp Fast Flashing: flashes when fault alarm occurs (5 times for 1 second);
Load Live	Lamp On: When S1 close signal input is active or S2 close signal input is active.
Auto Trans./Auto Res.	Lamp On: Current status is Auto Transfer/Auto Restore.
Auto Trans./Non-Res.	Lamp On: Current status is Auto Transfer/Non Restore.
Manual Mode	Lamp On: Current mode is Manual mode.
Auto Mode	Lamp On: Current mode is Auto mode.

6.2 KEY FUNCTION DESCRIPTION

Table 7 – Keys Description

Icon	Keys	Description
	S1 Close	Active in manual mode; Press and S1 close outputs, S1 connects to load.
	Open	Active in manual mode; Press and load is disconnected.
	S2 Close	Active in manual mode; Press and S2 close outputs, S2 connects to load.
	Manual Mode	Press and set controller to manual mode.
	Auto Mode	Press and set controller to auto mode.
	Alarm Reset	Press and enter alarm page; press again to remove fault alarms.
	Up/Mute	In main page, press to scroll up screen; After entering menu page, move up cursor or increase the value where the cursor is; Press longer and it can mute alarms.
	Set/Confirm	In main page, press to enter menu page. After entering menu page, confirm key can move cursor and confirm the set information.
	Down/Lamp Test	In main page, press to scroll down screen; After entering menu page, move down cursor or decrease the value where the cursor is; In main page, pressing longer is lamp test; At lamp test, LCD backlight is on, LCD display is back, and all LEDs on the panel are illuminated.
	Return/Home	Press to return to the previous menu in parameter page while it returns to the first page in main screen; Press longer and it immediately returns to the first page of controller main screen.

7 LCD DISPLAY

7.1 MAIN SCREEN

Table 8 – Main Screen Display

Display Contents	Display Description
<p>U1 (LL) 380 380 380 V U2 (LL) 380 380 380 V F1 50.0Hz Bat 27.6V F2 50.0Hz Manual Mode</p>	<p>S1 Line Voltage (L1-L2, L2-L3, L3-L1) S2 Line Voltage (L1-L2, L2-L3, L3-L1) S1 Frequency S2 Frequency Current mode, alarm status, indication information, other status information</p>
<p>U1 (LN) 220 220 220 V U2 (LN) 220 220 220 V S1 Phase L1-L2-L3 S2 Phase L1-L2-L3 Electricity -----</p>	<p>S1 Phase Voltage (L1, L2, L3) S2 Phase Voltage (L1, L2, L3) S1 Phase Sequence S2 Phase Sequence Current page content and position, alarm status, indication information, and action countdown.</p>
<p>Amp 500 500 0.0A TkW 330 Load 0% Tkvar 0.0 TkVA 330 PF 1.00 Load -----</p>	<p>3 Phase Current Total Active Power and Current Power Percentage Total Reactive Power Total Apparent Power, Power Factor Current page content and position, alarm status, indication information and action countdown.</p>
<p>kW 110 110 110 kvar 0.0 0.0 0.1 kVA 110 110 110 PF 1.00 1.00 1.00 Load -----</p>	<p>3 Phase Active Power 3 Phase Reactive Power 3 Phase Apparent Power 3 Phase Power Factor Current page content and position, alarm status, indication information and action countdown.</p>
<p> 74V ✓ 0.1Hz ✓ 13° ✗ Sync. -----</p>	<p>Synchronous Voltage Difference (the difference of average value of 3-phase voltage) Synchronous Frequency Difference Synchronous Phase Difference and Analogue Synchronous Meter Parallel Mode Current page content and position, alarm status, indication information and action countdown.</p>
<p>RS485 <input type="checkbox"/> USB <input type="checkbox"/> Ethernet <input type="checkbox"/> 2022-11-08 (2) 10:15:30 Comm. -----</p>	<p>RS485 Communication Status USB Communication Status ETHERNET Port Communication Status Real Time Clock Current page content and position, alarm status, indication information and action countdown.</p>
<p>Cont. Power Supply Time 3: 25: 18 Last Cont. Power Supply 8: 15: 32 Total -----</p>	<p>Continuous Supply Time Hour: Minute: Second Continuous Supply Time (Last Time) Hour: Minute: Second Current page content and position, alarm status, indication information and action countdown.</p>

Display Contents	Display Description
<p>S1 Total Supply Time 3: 25: 18</p> <p>S2 Total Power Supply 8: 15: 32</p> <hr/> <p>Total -----</p>	<p>S1 Accumulated Supply Time Hour: Minute: Second</p> <p>S2 Accumulated Supply Time Hour: Minute: Second</p> <p>Current page content and position, alarm status, indication information and action countdown.</p>
<p>S1 Total kWh 2458.0kWh</p> <p>S2 Total kWh 3456.3kWh</p> <hr/> <p>Total -----</p>	<p>S1 Accumulated Active Power</p> <p>S2 Accumulated Active Power</p> <p>Current page content and position, alarm status, indication information and action countdown.</p>
<p>S1 Total kvarh 2458.0kvarh</p> <p>S2 Total kvarh 3456.3kvarh</p> <hr/> <p>Total -----</p>	<p>S1 Accumulated Reactive Power</p> <p>S2 Accumulated Reactive Power</p> <p>Current page content and position, alarm status, indication information and action countdown.</p>
<p>S1 Total Close Num 8</p> <p>S2 Total Close Num 10</p> <hr/> <p>Total -----</p>	<p>S1 Accumulated Close Times</p> <p>S2 Accumulated Close Times</p> <p>Current page content and position, alarm status, indication information and action countdown.</p>
<p>S1 Available</p> <p>S2 Available</p> <p>S1 On Load</p> <p>Genset Standby</p> <hr/> <p>Status -----</p>	<p>S1 Voltage Status</p> <p>S2 Voltage Status</p> <p>Switch Status</p> <p>Genset Status</p> <p>Current page content and position, alarm status, indication information and action countdown.</p>
<p>Alarms 01/05</p> <p>Warn Alarm</p> <p>Sync Failure</p> <p>Fault Alarm</p> <p>S2 Close Failure</p>	<p>Alarm Serial No. and Alarm Number</p> <p>Alarm Type (Warning Alarm, Fault Alarm)</p> <p>Alarm Event</p> <p>Alarm Type (Warning Alarm, Fault Alarm)</p> <p>Alarm Event</p>

NOTE: Above is HAT660S main screen display; HAT660B/HAT660BI display contents are less than above.

7.2 STATUS DESCRIPTION

Table 9 – S1 Power Status

No.	Status Name	Description
1	S1 Normal Identify	S1 normal identification delay
2	S1 Abnormal Identify	S1 abnormal identification delay
3	S1 Voltage Normal	Power value is within the specified range.
4	S1 Voltage None	Voltage is 0.
5	S1 Voltage High	Voltage is above the pre-set upper value.
6	S1 Voltage Low	Voltage is below the pre-set lower value.
7	S1 Frequency High	Frequency is above the pre-set upper value.
8	S1 Frequency Low	Frequency is below the pre-set lower value.
9	S1 Loss of Phase	Loss of one or two phase among A, B, C.
10	S1 Reverse Phase Sequence	Wrong phase sequence A-B-C.

Table 10 – S2 Power Status

No.	Status Name	Description
1	S2 Normal Identify	S2 normal identification delay
2	S2 Abnormal Identify	S2 abnormal identification delay
3	S2 Voltage Normal	Power value is within the specified range.
4	S2 Voltage None	Voltage is 0.
5	S2 Voltage High	Voltage is above the pre-set upper value.
6	S2 Voltage Low	Voltage is below the pre-set lower value.
7	S2 Frequency High	Frequency is above the pre-set upper value.
8	S2 Frequency Low	Frequency is below the pre-set lower value.
9	S2 Loss of Phase	Loss of one or two phase among A, B, C.
10	S2 Reverse Phase Sequence	Wrong phase sequence A-B-C.

Table 11 – Genset Status

No.	Status Name	Description
1	Start Delay	Delay time before genset start.
2	Stop Delay	Delay time before genset stop.
3	Scheduled Not Start	Display Scheduled Not Start lasting time when it is active.
4	Scheduled Start	Display Scheduled Start lasting time when it is active.
5	S1 Cycle Start	S1 Cycle Start finishing countdown when it is active.
6	S2 Cycle Start	S2 Cycle Start finishing countdown when it is active.
7	S1 Genset Start	Only active when system is "S1 Gen S2 Gen".
8	S2 Genset Start	Only active when system is "S1 Gen S2 Gen".
9	Genset Start	Genset start signal outputs.
10	Genset Standby	None genset signal outputs.

Table 12 – Switch Status

No.	Status Name	Description
1	Ready to Transfer	Enter switch transfer process;
2	S1 Closing	S1 closing delay is in progress;
3	S1 Opening	S1 opening delay is in progress;
4	S2 Closing	S2 closing delay is in progress;
5	S2 Opening	S2 opening delay is in progress;
6	Transfer Rest	Interval time between switch transfers;
7	Closing S1 Again	It is the second closing time when the first S1 opening is not successful;
8	Opening S1 Again	It is the second opening time when the first S1 closing is not successful;
9	Closing S2 Again	It is the second closing time when the first S2 opening is not successful;
10	Closing S2 Again	It is the second opening time when the first S2 closing is not successful;
11	Waiting Synch.	Delay time for waiting S1/S2 to meet synch. conditions (voltage difference, frequency difference, phase difference);
12	S1 Sync. Close	S1 synch. close outputs when synch. conditions are satisfied;
13	S2 Sync. Close	S2 synch. close outputs when synch. conditions are satisfied;
14	Waiting S1 PF	S1 is waiting for input setting (S1 gets ready/PF) is active before S1 closes;
15	Waiting S2 PF	S2 is waiting for input setting (S2 gets ready/PF) is active before S2 closes;
16	Elevator Delay	Delay time before switch transfer, elevator control outputs;
17	S1 On Load	S1 was already closed and S1 is taking load;
18	S2 On Load	S2 was already closed and S2 is taking load;
19	Offload	Switch was already opened and load is disconnected.

When controller detects that the warning alarm is active, alarm indicator will flash slowly (1 time 1 second); after warning is recovered, alarm indicator will extinguish. Warning alarm is not latched.

Table 13 – Warning Alarms

No.	Status Name	Description
1	S1 Over Current Warn	Action is set to warning; current is over pre-set limit when S1 is taking load;
2	S2 Over Current Warn	Action is set to warning; current is over pre-set limit when S2 is taking load;
3	Forced Open Warn	It alarms when the forced open (Non-firefighting cutoff input) action is warning, and the forced open input is active;
4	Fail to Sync. Warn	Sync. failure action is set to warning, and it alarms when synch. delay is over time;
5	Switch Output Voltage Abnormal	Input port is configured to "Output Voltage Abnormal Warn", and when the input is active, warning occurs.
6	Busbar Voltage Abnormal	Input port is configured to "Busbar Voltage Abnormal Warn", and when the input is active, warning occurs.

When controller detects that the fault alarm is active, alarm indicator will flash fast (5 time per second); Fault alarm is latched and it can be removed until reset it manually.

Table 14 – Fault Alarms

No.	Status Name	Description
1	S1 Failed to Close	S1 fails to close when it closes in auto mode;
2	S1 Failed to Open	S1 fails to open when it opens in auto mode;
3	S2 Failed to Close	S2 fails to close when it closes in auto mode;
4	S2 Failed to Open	S2 fails to open when it opens in auto mode;
5	S1 Load Over Current Trip	Action is set to trip; current is over preset limit when S1 is taking load;
6	S2 Load Over Current Trip	Action is set to trip; current is over preset limit when S2 is taking load;
7	Forced Open Fault	It alarms when the forced open (Non-firefighting cutoff input) action is fault, and the forced open input is active;
8	S1 Genset Fault	S1 cannot start normally when system is S1-Gen S2-Gen;
9	S2 Genset Fault	S2 cannot start normally when system is S1-Gen S2-Gen;
10	Breaker Trip Alarm	Breaker trip alarm input is active.
11	Sync Fail Fault	Sync. failure action is set to fault, when it is over delay time, fault alarms;
12	S1/S2 Close At the same time	It alarms when S1 close signal input and S2 close signal input are active at the same time for over 300ms;
13	Switch Output Voltage Abnormal	Input is configured to "Output Voltage Abnormal Fault", and when input is active, fault alarms.
14	S1 Switch Trip	S1 switch trip alarm input is active.
15	S2 Switch Trip	S2 switch trip alarm input is active.

When indication information is active, it disappears after it displays for 2s.

Table 15 – Indication Information

No.	Status Name	Description
1	Please reset the alarm	Reminder information for switching to auto mode manually before alarm is removed when fault alarm occurs;
2	S1 was already closed	In manual mode, the indication information for pressing S2 close key when S1 has been closed;
3	S2 was already closed	In manual mode, the indication information for pressing S1 close key when and S2 has been closed;
4	Panel Button Latched	When "panel button latched" input is active, it is the reminder information for pressing panel button (Auto key, Manual key, S1 Close key, S2 Close key, Open key, Alarm Reset key).

Table 16 – Other Status Information

No.	Status Name	Description
1	Start Inhibit	Genset start inhibition input is active;
2	Transfer Inhibit Input	In auto mode, it is active and ATS will no longer transfer.
3	S1 Load Inhibit	S1 close inhibition input is active;
4	S2 Load Inhibit	S2 close inhibition input is active;
5	NEL 1 Trip	NEL 1 unload outputs;
6	NEL 2 Trip	NEL 2 unload outputs;
7	NEL 3 Trip	NEL 3 unload outputs;
8	Remote Gen On Load	Remote start with load input is active;
9	Remote Gen Off Load	Remote start without load input is active;
10	Mains Abnormal Gen Start	Genset starts when mains is abnormal;
11	Genset Start	Active when genset starts;
12	Auto Mode	Current status is Auto mode;
13	Manual Mode	Current status is Manual mode.
14	Local Mode	Current status is Local Mode.



7.3 MAIN MENU INTERFACE

In the main screen, press /OK key and it can enter the main menu interface.

<ol style="list-style-type: none"> 1. Configuration 2. History Records 3. Black Box Records 4. Harmonics Analysis 5. Auto Trans./Restore 	<p>Press /OK and /gear to select different parameter line (backlight), and then press /OK to enter related display screen.</p>
<ol style="list-style-type: none"> 6. Auto Trans./Restore 7. Start/Stop Genset 8. Language 8. Module Info 10. About 	

▲NOTE : Input password to enter parameter settings; default password "01234"; operator can change the password to prevent others changing controller configurations randomly. After change please remember clearly; If it is forgotten, please contact company personnel.

8 GENSET START/STOP OPERATION

8.1 START/STOP GENSET IN MANUAL MODE

8.1.1 START/STOP GENSET ON PANEL

In main menu interface, select "7. Start/Stop Genset", and enter genset start operation manually.

When system type is "S1 Mains S2 Gen", "S1 Gen S2 Mains", "S1 Mains S2 Mains", start/stop genset manually.

Menu interface is as below.

<ol style="list-style-type: none"> 1. Return 2. Genset Stop 3. Genset Start 	<p>Press Up/Down key to select different parameter line (backlight), and press Confirm key to confirm.</p>
--	--

Genset Stop: Disconnect the outputted genset start signal, which is to control genset stop.

Genset Start: Control genset start signal output, which is to control genset start.

For system "S1 Gen S2 Gen", manual genset start/stop menu interface is as below.

<ol style="list-style-type: none"> 1. Return 2. S1 Genset Stop 3. S1 Genset Start 4. S2 Genset Stop 5. S2 Genset Start 	<p>Press Up/Down key to select different parameter line (backlight), and press Confirm key to confirm.</p>
---	--

S1 Genset Stop: Disconnect the outputted S1 genset start signal, which is to control S1 genset stop.

S1 Genset Start: Control S1 genset start signal output, which is to control S1 genset start.

S2 Genset Stop: Disconnect the outputted S2 genset start signal, which is to control S2 genset stop.

S2 Genset Start: Control S2 genset start signal output, which is to control S2 genset start.

8.1.2 REMOTE START/STOP GENSET

Send remote start/stop commands by RS485 port (Modbus-RTU protocol control), ETHERNET port (Modbus TCP/IP protocol control).

Remote Stop: Disconnect the outputted genset start signal, which is to control genset stop.

Remote Start: Control genset start signal output, which is to control genset start.

8.2 START/STOP GENSET IN AUTO MODE

8.2.1 START CONDITIONS

— Input Port Start

Configure "Remote Start On Load" or "Remote Start Off Load", they cannot be set at the same time.

Remote Start On Load: Genset start outputs, when generating is OK, gen closes; when it is inactive, genset start output signal is disconnected.

Remote Start Off Load: Genset start outputs, when mains is OK, mains closes; when it is inactive, genset start output signal is disconnected.

— Mains Abnormal Start

When mains is abnormal, genset start outputs; when generating is OK, gen closes.

8.2.2 START/STOP OF TWO GENSETS

System type is "S1-Gen S2-Gen", and input port settings are as below.

Set programmable input port to "Remote Start On Load", or "Remote Start Off Load", and they cannot be set at the same time.

Remote Start On Load: According to start method, judge S1 or S2 start output; when generating is OK, gen closes;

Remote Start Off Load: According to start method, judge S1 or S2 start output; after gensets are started, both gen S1 and S2 don't close.

Start method of two gensets: Cycle Gen Start Mode, Master-Slave Gen Mode, Balance Gen Hours Mode, Not Used.

— Cycle Gen Start

When remote start is active, S1 and S2 will start according to cycle running time. For the first start, controller selects S1 or S2 start based on master status; for example, if S1 is master, then S1 starts first. then countdown starts based on the pre-set S1 cycle running time, and at the same time genset fault identification countdown is initiated. Before the end of fault identification countdown if S1 generating is normal, S1 takes the load as soon as it is normal. After the end of S1 cycle running countdown, S2 starts and S2 cycle running countdown is initiated; at the same time genset fault identification countdown starts; Before the end of fault identification countdown, if S2 generating is OK, it will take the load as soon as it is normal. S1 stops. It goes in this way until remote start is inactive.

In the process of genset start, if genset fault (power supply delay overtime or genset fault input is active), failed to close, load inhibit, occurs, controller will immediately stop the current started genset, and start the other genset.

During the process of cycle running, if it transfers to manual mode, it will keep the current status, and stop the cycle running timing.

— Master-Slave Gen Mode

When remote start is active, master genset starts. In the process of genset start, when genset fault (genset supply delay overtime, or genset fault input), failed to close, load inhibit, occurs, controller will immediately stop the current started genset, and start the other genset. Otherwise master genset continues starting until remote start is inactive.

— **Balanced Running Start**

When remote start is active, the short accumulated running unit starts, when the current unit fault during the starting process (Gen supply delay or fault input), close failure, inhibit on load, try to stop the current running unit and start another unit, otherwise the current unit will continue to start running until the remote start is inactive.

The following conditions are required to do genset start/stop when system type is "S1-Gen S2-Gen".

- 1) Active in auto mode;
- 2) System type is set to "S1-Gen S2-Gen";
- 3) Output port shall be set to "S1 Genset Working" and "S2 Genset Working";
- 4) Input port shall be set to "S1 Genset Fault Input", "S2 Genset Fault Input", and "Remote Start On Load" or "Remote Start Off Load";
- 5) "Gen-Gen Start Mode" shall be set;
- 6) "Genset Available Time" shall be programmed; if start method is Cycle Start, "S1 Cycle Work Time" and "S2 Cycle Work Time" shall be set.

"S1 Genset Fault Input" and "S2 Genset Fault Input" in the input ports are alternate configurations. Users can also judge whether there is genset fault by "Genset Available Time", without connecting genset status in the input port.

When S1 Gen S2 Gen start method is set to None, there will not any genset start signal output.

For example:

Table 17 – Start Example Illustration

System Type	Start Conditions	Start Result
S1 Gen S2 Gen	Input port is active. (Remote Start On Load/Remote Start Off Load)	S1 genset start outputs.
	Master set is set to: S1 Master	

8.2.3 SCHEDULED GEN START

When "Schedule Gen Enable" function is enabled, users can set scheduled gen start time. Controller will issue start signal when the time is up. When scheduled start lasting time is over, start signal is disconnected. Scheduled Run On Load or Off Load can be set.

Scheduled Start On Load: genset start outputs, and when generating is OK, gen closes;

Scheduled Start Off Load: genset start outputs, and when mains is OK, mains close.

Scheduled Start cycle time can be set to start monthly, weekly, or daily.

Schedule Monthly: which month to start, start date and time can be set.

Schedule Weekly: start at the same time for multiple days in a week can be set. For example: Set it from Monday to Friday, start at 8:00 and last 10 hours.

Schedule Daily: start at the same time for each day can be set.

8.2.4 SCHEDULE NOT WORK

After Schedule Not Work function is enabled, users can set scheduled not work time. Controller will disconnect start signal when the scheduled time is due. Start signal is prohibited before the end of Scheduled Not Work lasting time.

Scheduled Not Work cycle time can be set to Not Run Monthly, Weekly, Daily, three methods.

Scheduled Not Work Monthly: Which month to not run can be set, so do not run date and time;



Scheduled Not Work Weekly: Not run for multiple days in a week can be set; For example: Set it from Monday to Friday, not run at 19:00 every day, lasting for 12 hours;

Scheduled Not Work Daily: Not run at the same time every day can be set.

▲NOTE: Schedule Not Work is prior to Schedule Start Operation.

9 PARAMETER SETTINGS

9.1 ILLUSTRATION

In the first page of the main screen, press  key and enter menu page. Select "1. Configuration", and press  to confirm, so it enters parameter setting password interface. Input correct password to enter parameter main screen. If password is wrong, it directly returns back to main screen. Default factory password: **01234**. In parameter configuration screen, press  key to return to the previous directory.

9.2 PARAMETER CONFIGURATION LIST

Table 18 – Parameter Setting Items

No.	Item	Range	Default	Description
AC Settings				
1	S1 Available Delay	(0-3600)s	10	The check time for S1 from abnormal to normal;
2	S1 Unavailable Delay	(0-3600)s	5	The check time for S1 from normal to abnormal;
3	S2 Available Delay	(0-3600)s	10	The check time for S2 from abnormal to normal;
4	S2 Unavailable Delay	(0-3600)s	5	The check time for S2 from normal to abnormal;
5	Master-Slave Set	(0~1)	0	0: S1 Master 1: S2 Master
6	System Type Set	(0~3)	0	0: S1 Mains S2 Gen 1: S1 Gen S2 Mains 2: S1 Mains S2 Mains 3: S1 Gen S2 Gen
7	AC System	(0-3)	0	0: 3P4W 1: 3P3W 2: 2P3W 3: Single Phase 2-Wire
8	PT Fitted	(0~1)	0	0: Disable 1: Enable
9	PT Primary Voltage	(30~35000)V	100	Primary voltage of AC PT ratio;
10	PT Secondary Voltage	(30~1000)V	100	Secondary voltage of AC PT ratio;
11	Rated Voltage	(0-35000)V	220	Rated voltage of AC system;
12	Over Volt Set	(0~1)	1	0: Disable 1: Enable
13	Set Value	(0-200)%	120	Upper limit value of voltage; it is abnormal if the value has exceeded the set value.
14	Return Value	(0-200)%	115	Upper limit return value of voltage; it is normal only when the value has fallen below the set value.
15	Under Volt Set	(0~1)	1	0: Disable 1: Enable
16	Set Value	(0-200)%	80	Lower limit value of voltage; it is abnormal if the value has fallen below the set value.
17	Return Value	(0-200)%	85	Lower limit return value of voltage; it is normal only when the value has exceeded the set value.
18	Rated Frequency	(10.0-75.0)Hz	50.0	Rated frequency of AC system

No.	Item	Range	Default	Description
19	Over Frequency Set	(0-1)	1	0: Disable 1: Enable
20	Set Value	(0-200)%	110	Upper limit value of frequency; it is abnormal if the value has exceeded the set value.
21	Return Value	(0-200)%	104	Upper limit return value of frequency; it is normal only when the value has fallen below the set value.
22	Under Frequency Set	(0-1)	1	0: Disable 1: Enable
23	Set Value	(0-200)%	90	Lower limit value of frequency; it is abnormal if the value has fallen below the set value.
24	Return Value	(0-200)%	96	Lower limit return value of frequency; it is normal only when the value has exceeded the set value.
25	Phase Sequence Wrong	(0-1)	1	0: Disable 1: Enable
Switch Settings				
1	Power Supply Type	(0~1)	1	0: DC power supply 1: AC power supply
2	AC Power Voltage Lower Limit	(0~200)%	70	The min. AC power voltage, the switch cannot transfer if lower than this value.
3	AC Power Voltage Upper Limit	(0~400)%	130	The max. AC power voltage, the switch cannot transfer if higher than this value.
4	Definite C/O Time	(0~1)	0	0: Disable 1: Enable Disable: Detect output time according to close status when close/open pulse outputs; longest time is the set time; Enable: close/open pulse output time is the set close/open time;
5	Close Time	(0.1~20.0)s	5.0	Outputted pulse time of close relay;
6	Open Time	(0.1~20.0)s	5.0	Outputted pulse time of open relay;
7	Transfer Time	(0~9999)s	1	Delay time from S1 open to S2 close; or from S2 open to S1 close;
8	Again Close Time	(0-20.0)s	1.0	If the first switch open is not successful, then the second close starts and again close delay starts; when the delay is over, then the second open starts; if the open cannot be conducted, then open failure alarm signal shall be sent out;
9	Again Open Time	(0-20.0)s	1.0	If the first switch close is not successful, then the second open starts and again open delay starts; when the delay is over, then the second close starts; if the close cannot be conducted, then close failure alarm signal shall be sent out;
10	Switch Type	(0~2)	0	0: CB/CC (S1 Open and S2 Open control is needed.) 1: PC Three-stage (For PC switch with neutral, S1 open control is needed.) 2: PC Two-stage (For PC switch without neutral)
11	Forced Open Action	(0-1)	0	0: Warn Alarm

No.	Item	Range	Default	Description
				1: Fault Alarm
12	Continually Close	(0~1)	0	0: Disable 1: Enable It needs to be enabled when close control is continuous signal and close/open time is inactive at this time;
13	Load SW Transfer Time	(0-9999)s	1	Load switch outputs of 4 circuits are configured by output ports; time interval for each switch output;
14	Load SW Close Time	(0-20)s	5	Output time for load switch; when it is set 0, load switch output is continuous output;
15	No Opening Transfer Enabled	(0~1)	0	0: Disable 1: Enable When it enables, the controller will transfer from S1 to S2, and there is no opening control output during the transferring process.
16	Parallel Mode Set	(0~3)	0	0: Non-parallel 1: Manual auto parallel; 2: Automatic parallel; 3: Manual parallel.
17	Volt Diff. Enabled	(0~1)	0	0: Disable 1: Enable
18	Volt Diff.	(0~50)V	5	Max. voltage difference when sync. is completed;
19	Freq Diff.	(0~0.50)Hz	0.20	Max. frequency difference when sync. is completed;
20	Phase Diff.	(0~20) °	5	Max. phase difference when sync. is completed;
21	Fail to Sync Action	(0~1)	0	0: Warn Alarm 1: Fault Alarm It continues to wait for sync when sync fails until it closes after sync; For warning alarm, it is removed when sync is completed or exit from sync. For fault alarm, it needs to press alarm reset to remove alarm.
22	Transfer in Sync Fail	(0~1)	0	0: Disable 1: Enable After sync fails, close without sync shall be conducted and fail to sync alarm also isn't issued;
23	Fail to Sync Delay	(0~9999)s	120	Time for waiting for sync success; if it is over time, then sync fails;
24	Sync. Close/Open Detection Time	(0.1~1.0)s	0.6	At the time of sync transfer, sync close/open output delay starts; during this period if correct close status is detected, then stop close/open pulse output; if delay is over and close/open status is not detected, then close/open failure alarm shall be initiated;
Genset Settings				
1	Genset Start Delay	(0~9999)s	1	When genset prepares to start, delay starts, and when the delay is over,

No.	Item	Range	Default	Description
				genset starting signal is sent out;
2	Genset Stop Delay	(0~9999)s	5	When genset prepares to stop, delay starts, and when the delay is over, genset starting signal is disconnected;
3	Gen-Gen Start Mode	(0~3)	0	0: Cycle Gens 1: Master-Slave Gens 2: Balance Gens Hours 3: Not Used
4	S1 Cycle Work Time	(0~9999)min	720	The running time of S1 at the mode of Cycle Gens;
5	S2 Cycle Work Time	(0~9999)min	720	The running time of S2 at the mode of Cycle Gens;
6	Genset Available Time	(0~9999)s	120	Time from issuing genset start signal to gen voltage is normal; if delay is over and gen voltage is still abnormal, then genset fault alarm is initiated;
Scheduled Start/Stop Settings				
1	Schedule Gen Enable	(0~1)	0	0: Disable 1: Enable
2	Schedule Load	(0~1)	0	0: Off Load 1: On Load
3	Schedule Period	(0~2)	0	0: Monthly 1: Weekly 2: Daily
4	Schedule Monthly	(1~4095)	4095	Bit0: January Bit1: February Bit2: March Bit3: April Bit4: May Bit5: June Bit6: July Bit7: August Bit8: September Bit9: October Bit10: November Bit11: December
5	Schedule Date	(1~31)	1	Date of genset start in every month;
6	Schedule Weekly	(1~127)	1	Bit0: Sunday Bit1: Monday Bit2: Tuesday Bit3: Wednesday Bit4: Thursday Bit5: Friday Bit6: Saturday
7	Schedule Hours	(0~23)h	0	Scheduled start time;
8	Schedule Minutes	(0~59)min	0	
9	Schedule Work Time	(0~30000)min	30	The lasting time for scheduled start running;
10	Gen Inhibit Work	(0~1)	0	0: Disable 1: Enable
11	Inhibit Period	(0~2)	0	0: Monthly 1: Weekly 2: Daily
12	Inhibit Monthly	(1~4095)	4095	Bit0: January Bit1: February

No.	Item	Range	Default	Description
				Bit2: March Bit3: April Bit4: May Bit5: June Bit6: July Bit7: August Bit8: September Bit9: October Bit10: November Bit11: December
13	Inhibit Date	(1~31)	1	Date of not start in every month;
14	Inhibit Weekly	(1~127)	1	Bit0: Sunday Bit1: Monday Bit2: Tuesday Bit3: Wednesday Bit4: Thursday Bit5: Friday Bit6: Saturday
15	Inhibit Hours	(0~23) h	0	Time for scheduled non-start;
16	Inhibit Minutes	(0~59) min	0	
17	Inhibit Rest Time	(0~30000) min	30	The lasting time for scheduled non-start;
Load Settings				
1	Elevator Enable	(0~1)	0	0: Disable 1: Enable
2	Elevator Delay	(0~300)s	300	Delay time for load power off or before switch transfer; used to control the running elevator stop at the nearest level until switch transfer is finished;
3	Current CT Enable	(0~1)	1	0: Disable 1: Enable
4	CT Primary/5	(5~6000)A	500	Primary Current of CT;
5	S1 Full Load Rating	(5~6000)A	500	Current of S1 full load;
6	S2 Full Load Rating	(5~6000)A	500	Current of S2 full load;
7	S1 Max kW Rating	(1~20000)kW	200	Max. active power of S1 full load;
8	S2 Max kW Rating	(1~20000)kW	200	Max. active power of S2 full load;
9	Over Current Enable	(0~1)	1	0: Disable 1: Enable
10	Over Current	(0~200)%	120	Limits for over current;
11	Over Current Protection	(0~1)	0	0: Warn 1: Trip
12	Over Current Type	(0~1)	0	0: Definite 1: Inverse Definite
13	Definite Delay Set (Value)	(0~3600)s	10	Over current delay value for definite time;
14	Inverse Delay Set (Multiplier)	(1~36)	36	Over current delay multiplier for inverse definite;
15	NEL Enable	(0~1)	0	0: Disable 1: Enable
16	NEL Over Power Val 1	(0~200)%	90	When load power is over the set value, unload control outputs after delay;
17	NEL Over Power Delay 1	(0~3600)s	5	
18	NEL Over Power Val 2	(0~200)%	100	When load power is over the set value, unload control outputs after delay;

No.	Item	Range	Default	Description
19	NEL Over Power Delay 2	(0~3600)s	1	
20	NEL Return Enable	(0~1)	0	0: Disable 1: Enable
21	NEL Return Value	(0~200)%	50	When load power is lower than the set value, unload control is disconnected after delay;
22	NEL Return Delay	(0~3600)s	5	
23	NEL Nums	(1~3)	3	NEL numbers;
24	Mains Load NEL Enable	(0~1)	0	0: Disable 1: Enable
Digital Input Settings				
1	Digital Input 1	(0~45)	36	S1 close signal input
2	Active Type	(0~1)	0	0: Close to activate; 1: Open to activate
3	Digital Input 2	(0~45)	42	S1 switch trip input
4	Active Type	(0~1)	0	0: Close to activate; 1: Open to activate
5	Digital Input 3	(0~45)	37	S2 close signal input
6	Active Type	(0~1)	0	0: Close to activate; 1: Open to activate
7	Digital Input 4	(0~45)	43	S2 switch trip input
8	Active Type	(0~1)	0	0: Close to activate; 1: Open to activate
9	Digital Input 5	(0~45)	1	Forced to open
10	Active Type	(0~1)	0	0: Close to activate; 1: Open to activate
11	Digital Input 6	(0~45)	8	Switch trip input
12	Active Type	(0~1)	0	0: Close to activate; 1: Open to activate
13	Digital Input 7	(0~45)	0	Not used
14	Active Type	(0~1)	0	0: Close to activate; 1: Open to activate
Digital Output Settings				
1	Digital Output 1 Active Type	(0~1)	0	0: Output (N/O); 1: Output (N/C)
2	Digital Output 1	(0~92)	34	S1 switch close control
3	Digital Output 2 Active Type	(0~1)	0	0: Output (N/O); 1: Output (N/C)
4	Digital Output 2	(0~92)	36	S2 switch close control
5	Digital Output 3 Active Type	(0~1)	0	0: Output (N/O); 1: Output (N/C)
6	Digital Output 3	(0~92)	35	S1 switch open control
7	Digital Output 4 Active Type	(0~1)	0	0: Output (N/O); 1: Output (N/C)
8	Digital Output 4	(0~92)	37	S2 switch open control
9	Digital Output 5 Active Type	(0~1)	0	0: Output (N/O); 1: Output (N/C)
10	Digital Output 5	(0~92)	32	Genset start
11	Digital Output 6 Active Type	(0~1)	0	0: Output (N/O); 1: Output (N/C)
12	Digital Output 6	(0~92)	11	Common alarm
13	Digital Output 7 Active Type	(0~1)	0	0: Output (N/O); 1: Output (N/C)
14	Digital Output 7	(0~92)	1	Custom output combination 1
15	Combined 1 Or	(0~1)	0	0: Output (N/O);

No.	Item	Range	Default	Description
	Output 1 Active Type			1: Output (N/C)
16	Combined 1 Or Output 1 Contents	(0~92)	23	S1 voltage is normal;
17	Combined 1 Or Output 2 Active Type	(0~1)	0	0: Output (N/O); 1: Output (N/C)
18	Combined 1 Or Output 2 Contents	(0~92)	25	S2 voltage is normal;
19	Combined 1 and Output Active Type	(0~1)	1	0: Output (N/O); 1: Output (N/C)
20	Combined 1 and Output Contents	(0~92)	0	Not Used
21	Combined 2 or Output 1 Active Type	(0~1)	0	0: Output (N/O); 1: Output (N/C)
22	Combined 2 or Output 1 Contents	(0~92)	0	Not Used
23	Combined 2 or Output 2 Active Type	(0~1)	0	0: Output (N/O); 1: Output (N/C)
24	Combined 2 or Output 2 Contents	(0~92)	0	Not Used
25	Combined 2 and Output Active Type	(0~1)	0	0: Output (N/O); 1: Output (N/C)
26	Combined 2 and Output Contents	(0~92)	0	Not Used
27	Combined 3 or Output 1 Active Type	(0~1)	0	0: Output (N/O); 1: Output (N/C)
28	Combined 3 or Output 1 Contents	(0~92)	0	Not Used
29	Combined 3 or Output 2 Active Type	(0~1)	0	0: Output (N/O); 1: Output (N/C)
30	Combined 3 or Output 2 Contents	(0~92)	0	Not Used
31	Combined 3 and Output Active Type	(0~1)	0	0: Output (N/O); 1: Output (N/C)
32	Combined 3 and Output Contents	(0~92)	0	Not Used
33	Combined 4 or Output 1 Active Type	(0~1)	0	0: Output (N/O); 1: Output (N/C)
34	Combined 4 or Output 1 Contents	(0~92)	0	Not Used
35	Combined 4 or Output 2 Active Type	(0~1)	0	0: Output (N/O); 1: Output (N/C)
36	Combined 4 or Output 2 Contents	(0~92)	0	Not Used
37	Combined 4 and Output Active Type	(0~1)	0	0: Output (N/O); 1: Output (N/C)
38	Combined 4 and Output Contents	(0~92)	0	Not Used
39	Combined 5 or	(0~1)	0	0: Output (N/O);

No.	Item	Range	Default	Description
	Output 1 Active Type			1: Output (N/C)
40	Combined 5 or Output 1 Contents	(0~92)	0	Not Used
41	Combined 5 or Output 2 Active Type	(0~1)	0	0: Output (N/O); 1: Output (N/C)
42	Combined 5 or Output 2 Contents	(0~92)	0	Not Used
43	Combined 5 and Output Active Type	(0~1)	0	0: Output (N/O); 1: Output (N/C)
44	Combined 5 and Output Contents	(0~92)	0	Not Used
45	Combined 6 or Output 1 Active Type	(0~1)	0	0: Output (N/O); 1: Output (N/C)
46	Combined 6 or Output 1 Contents	(0~92)	0	Not Used
47	Combined 6 or Output 2 Active Type	(0~1)	0	0: Output (N/O); 1: Output (N/C)
48	Combined 6 or Output 2 Contents	(0~92)	0	Not Used
49	Combined 6 and Output Active Type	(0~1)	0	0: Output (N/O); 1: Output (N/C)
50	Combined 6 and Output Contents	(0~92)	0	Not Used
51	Combined 7 or Output 1 Active Type	(0~1)	0	0: Output (N/O); 1: Output (N/C)
52	Combined 7 or Output 1 Contents	(0~92)	0	Not Used
53	Combined 7 or Output 2 Active Type	(0~1)	0	0: Output (N/O); 1: Output (N/C)
54	Combined 7 or Output 2 Contents	(0~92)	0	Not Used
55	Combined 7 and Output 2 Active Type	(0~1)	0	0: Output (N/O); 1: Output (N/C)
56	Combined 7 and Output 2 Contents	(0~92)	0	Not Used
Module Settings				
1	Language	(0~2)	0	0: Simplified Chinese 1: English 2: Other (Users can self-define module language by PC software; default: English.)
2	Password	(00000~65535)	01234	For entering parameter setting
3	Power On Mode	(0~2)	0	0: Last Mode (reserved the mode before power off) 1: Manual 2: Auto
4	Module Address	(1~254)	1	RS485 communication address
5	Com Baud Rate	(0~3)	2	0: 2400 bps

No.	Item	Range	Default	Description
				1: 4800 bps 2: 9600 bps 3: 19200 bps
6	Com Stop Bit	(1~2)	2	1/2 bit can be set;
7	Com Parity	(0~2)	0	0: None 1: Odd Parity 2: Even Parity
8	Communication Set	(0~3)	0	0: Enable COM Adj/Ctrl 1: Disable COM Control 2: Disable COM Adjust 3: Disable COM Adj/Ctrl
9	Date/Time Setting			
10	LCD Backlight Delay	(1-3600)min	5	Enlightened time for LCD backlight;
11	Controller Information 1	(0-20) characters		Information displayed in ABOUT page; Users can input any character (letter is 1 character; while Chinese character is 2 characters), and it needs to set on PC by software;
12	Controller Information 2	(0-20) characters		
13	Controller Information 3	(0-20) characters		
Network Settings				
1	Network Enable	(0~1)	1	0: Disable 1: Enable
2	IP Address	192.168.0.100		ETHERNET communication parameters;
3	Subnet Mask	255.255.255.0		
4	Gateway	192.168.0.1		
5	MAC Address	Set through PC software		

9.3 DIGITAL INPUT PORT FUNCTION DESCRIPTION

Table 19 – Input Port Function Description

No.	Item	Description
0	Not Used	Invalid
1	Forced Open	It (Non-firefighting cutoff input) is only suitable for switches with breaker control; when it is active, switches shall changeover to neutral no matter in manual mode or in auto mode.
2	Remote Start on Load	Genset start outputs, and when mains is normal, close the generating breaker.
3	Remote Start off Load	Genset start outputs, and when mains is normal, gen breaker will not close.
4	Lamp Test	LED indicators are all light; LED backlight is light; LED is all dark.
5	S1 Genset Fault Input	Prohibit S1 genset start when S1 genset has fault (used in circular starting).
6	S2 Genset Fault Input	Prohibit S2 genset start when S2 genset has fault (used in circular starting).
7	Start Inhibit Input	Prohibit genset start signal output; In auto mode, disconnect start signal output when stop delay is over; In manual mode, start is inactive after genset stop when it is stopped manually if it has started;
8	Switch Trip Input	Breaker trip fault input.
9	S1 Close Inhibit	S1 close on load are prohibited; In manual mode, manual close is prohibited; if it is closed, then it needs to open manually; In auto mode, if it is closed then load is disconnected or S2 takes load;
10	S2 Close Inhibit	S2 close on load are prohibited; In manual mode, manual close is

No.	Item	Description
		prohibited; if it is closed, then it needs to open manually; In auto mode, if it is closed then load is disconnected or S1 takes load;
11	S1 Breaker PF IN	S1 close ready signal input; waiting for S1 PF input is active before S1 close;
12	S2 Breaker PF IN	S2 close ready signal input; waiting for S2 PF input is active before S2 close;
13	Key S1 Close	Same as S1 close key on the panel, and it is needed to select auto reset button.
14	Key S2 Close	Same as S2 close key on the panel, and it is needed to select auto reset button.
15	Alarm Reset	Remove current alarm;
16	Alarm Mute	Stop audible alarm output;
17	NEL Trip Key	Control NEL unload manually; it is needed to select auto reset button;
18	NEL Return Key	Control NEL to load again manually; it is needed to select auto reset button;
19	S1 Master Input	Forcibly set S1 switch priority the highest;
20	S2 Master Input	Forcibly set S2 switch priority the highest;
21	Forced Manual Mode	Forcibly set controller mode as manual mode.
22	Forced Auto Mode	Forcibly set controller mode as manual mode.
23	Panel Lock	Panel button operation is prohibited; Up/Down/Set/Return/Alarm Reset can be used;
24	Sync Inhibit	Sync transfer function is inactive;
25	Scheduler Inhibit	Scheduled start and scheduled not start functions are inactive;
26	Simulate S1 OK	Simulate S1 power is normal; S1 voltage detection is inactive;
27	Simulate S2 OK	Simulate S2 power is normal; S2 voltage detection is inactive;
28	Open IN	Same as panel open key, used to control switch open, please use auto reset button.
29	Local Mode	In this mode, the controller only displays "Not control".
30	Auto Trans./Restore	After this port is configured, it is Auto Trans./Restore when it is active; it is Auto Trans./Non Restore when it is inactive.
31	Switch Output Voltage Abnormal Fault	After this port is configured, fault alarm occurs when it is active. (HVD100 voltage detection module as signal input is needed.)
32	Switch Output Voltage Abnormal Warn	After this port is configured, warning alarm occurs when it is active. (HVD100 voltage detection module as signal input is needed.)
33	Remote Control Inhibit	When it is active, all remote control commands by communication port are inactive.
34	Transition Inhibit	In Auto mode, after this signal is active, it can inhibit ATS to transfer.
35	Busbar Voltage Abnormal	After this port is configured, warning alarm occurs when it is active.
36	S1 Closing Signal Input	To detect the closing status of S1 switch.
37	S2 Closing Signal Input	To detect the closing status of S2 switch.
38	Non Parallel	Set the parallel mode as "non-parallel", the parallel mode is inhibited in this mode.
39	Auto Parallel	Set the parallel mode as "auto parallel", in auto mode, the auto restore of main power will be automatically transferred in parallel. Only for HAT660S.
40	Manual Parallel	Set the parallel mode as "manual parallel", in auto mode, the controller can be manually transferred in parallel. Only for HAT660S.
41	Manual Auto Parallel	Set the parallel mode as "manual auto parallel", both manual and auto modes (auto restore) can be transferred in parallel. Only for HAT660S.

No.	Item	Description
42	S1 Switch Trip Input	S1 switch trip fault input.
43	S2 Switch Trip Input	S2 switch trip fault input.
44	Reserved	
45	Reserved	

SmartGen

9.4 DIGITAL OUTPUT PORT FUNCTION DESCRIPTION

Table 20 – Output Port Function Description

No.	Items	Description
0	Not Used	Output port is inactive.
1	Custom Combined 1	
2	Custom Combined 2	
3	Custom Combined 3	
4	Custom Combined 4	
5	Custom Combined 5	
6	Custom Combined 6	
7	Custom Combined 7	
8	Reserved	
9	Reserved	
10	Reserved	
11	Common Alarm	It includes fault alarm and warning alarm.
12	Common Fault Alarm	It includes "Transition Fault" alarm, and "Over Current" trip alarm.
13	Common Warn Alarm	It includes reverse phase sequence of S1, reverse phase sequence of S2, load over current and forced open.
14	Transition Fault	It includes "S1 Fail to Close" alarm, "S1 Fail to Open" alarm, "S2 Fail to Close" alarm, "S2 Fail to Open" alarm.
15	Audible Alarm	It can be connected with annunciator externally when common alarm is active. When "alarm mute" input is active or 60s delay has expired, it can remove the alarm.
16	Reserved	
17	Genset Start Delay	Output when genset start delay is initiated;
18	Genset Stop Delay	Output when genset stop delay is initiated;
19	Elevator Control	Output before load is power off or switch transfer; used to control running elevator to stop at the nearest level until transfer is finished;
20	Fire Control Linkage	Output when forced to open (Fire) input signal is active and ATS succeeds to open.
21	Busbar Voltage Abnormal Output	Output when busbar voltage abnormal warning input is active.
22	Reserved	
23	S1 Available	Output when S1 voltage is normal.
24	S1 Unavailable	Output when S1 voltage is abnormal.
25	S2 Available	Output when S2 voltage is normal.
26	S2 Unavailable	Output when S2 voltage is abnormal.
27	S1 Over Current	Output when S1 is over current with load;
28	S2 Over Current	Output when S2 is over current with load;
29	Local Mode	Output when the local mode is active.
30	Auto Mode	Output when the genset is in Auto mode.
31	Manual Mode	Output when the genset is in Manual mode.
32	Genset Start Output	Control the genset starting.
33	Reserved	
34	S1 Close Control	Control the S1 switch to close.
35	S1 Open Control	Control the S1 switch to open.
36	S2 Close Control	Control the S2 switch to close.
37	S2 Open Control	Control the S2 switch to open.
38	Reserved	
39	Reserved	
40	NEL1 Trip Control	Control NEL unload when output is active; used to control NEL unload and return (on load) when output is inactive;
41	NEL2 Trip Control	
42	NEL3 Trip Control	

No.	Items	Description
43	Reserved	
44	Reserved	
45	S1 Closed Status	The closed status of S1;
46	S2 Closed Status	The closed status of S2;
47	S1 Genset Start	Control S1 genset start; used for system S1-Gen S2-Gen;
48	S2 Genset Start	Control S2 genset start; used for system S1-Gen S2-Gen;
49	Input 5 Status	Programmable input status;
50	Input 6 Status	
51	Input 7 Status	
52	Reserved	
53	Remote Control Output	It is controlled by RS485 communication command.
54	Input 1 Status	Programmable input status;
55	Input 2 Status	
56	Input 3 Status	
57	Input 4 Status	
58	Load 1 Close	Load 1-4 close in order after S1 load supply or S2 load supply; After ATS open, load switch close outputs are all disconnected;
59	Load 2 Close	
60	Load 3 Close	
61	Load 4 Close	
62	Reserved	
63	Reserved	
64	S1 Blackout	S1 power status;
65	S1 Over Volt	
66	S1 Under Volt	
67	S1 Over Freq	
68	S1 Under Freq	
69	S1 Loss Of Phase	
70	S1 Phase Seq Wrong	
71	Reserved	
72	Reserved	
73	S2 Blackout	S2 power status;
74	S2 Over Volt	
75	S2 Under Volt	
76	S2 Over Freq	
77	S2 Under Freq	
78	S2 Loss Of Phase	
79	S2 Phase Seq Wrong	
80	Reserved	
81	Reserved	
82	Sync Fail	Only for HAT660S;
83	Sync Waiting	Only for HAT660S;
84	Switching	Output in the process of switch transfer;
85	Reserved	
86	Reserved	
87	Gen Inhibit Work	Output in continuous time for scheduled not start;
88	Scheduler Gen Start	Output in continuous time for scheduled start;
89	Close Fault of Two Circuits at the same time	Output when the two circuits close at the same time;
90	Electrical Interlock Release	When parallel mode is active, the electrical interlock release will output. Only for HAT660S.
91	Unload Output	When S1 Mains and S2 Gen, S1 Gen and S2 Mains, unload outputs when mains is offload.
92	Reserved	

9.5 DEFINED COMBINATION OUTPUT

Defined combination output is composed by 3 parts: OR condition output SW1/SW2 and AND condition output SW3.

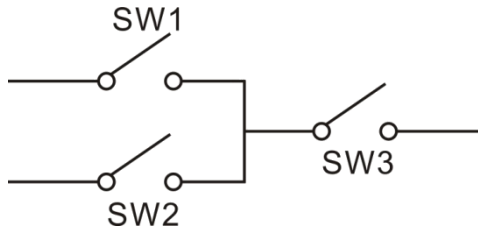

SW1 or SW2 is **TRUE**, and SW3 is **TRUE**, defined combination output is outputting;

SW1 and SW2 are **FALSE**, or SW3 is **FALSE**, defined combination output is not outputting.

▲NOTE 1: SW1, SW2, SW3 can be set as any contents except for “defined combination output” in the output settings.

▲NOTE 2: 3 parts of defined combination output (SW1, SW2, SW3) couldn’t include or recursively include themselves.

For example:

Contents of OR condition output SW1: Input port 1 is active;

Close when OR condition output SW1 is active /inactive: close when active (disconnect when inactive);

Contents of OR condition output SW2, input port 2 is active;

Close when OR condition output SW2 is active /inactive: close when active (disconnect when inactive);

Contents of AND condition output SW3: Input port 3 is active;

Close when AND condition output SW3 is active /inactive: close when active (disconnect when inactive);

Output result is as below:

When input port 1 active or input port 2 is active, if input port 3 is active, defined combination output is outputting; If input port 3 is inactive, defined combination output is not outputting;

When input port 1 is inactive and input port 2 is inactive, whatever input port 3 is active or not, defined combination output is not outputting.

9.6 Over Current Definite Time and Inverse Definite Time Settings

Definite Time: Over current delay is fixed delay; different over current values correspond to the same delay, which is the pre-set delay time;

Inverse Definite Time: Over current delay decreases as over current increases; different over current values correspond to different delays;

Inverse over current delay formula is as below:

$$T = \frac{t}{\left(\frac{IA}{IT} - 1\right)^2}$$

T: Over current delay value (s)

t: Timing multiplier

IA: Current maximum current (L1/L2/L3)

IT: Pre-set value of over current







For example:

Input conditions: t= 36, IA= 550A, IT= 500A

Output result: T= 3600s(1h)











10 HISTORICAL RECORDS

In menu interface, select "2. Historical Records", press  key to enter historical record interface.

Enter historical record page, press  and  to check every record.			
Action Event	010/200	Record type, serial No./total record number;	
Closing S2		Record event;	
S1 Blackout		S1 power status;	
S2 Available		S2 power status;	
2022-10-24	09:18:26	Record date and time;	
Press  to check the detailed information of current records.			
Action Event	010/200	Record type, serial No./total record number;	
Closing S2		Record event;	
U1 (LN)	0 0 0V	S1 phase voltage;	
U2 (LN)	220 221 219V	S1 phase voltage;	
F1	0.00Hz	F2 50.00Hz	S1 frequency, S2 frequency;
Press  and  to check the detailed information of current records. Press  or  key to exit current detailed information check.			
Action Event	010/200	Record type, serial No./total record number;	
Closing S2		Record event;	
Amp	130 145 136A	Load current;	
TkW	86 PF 1.00	Load active power and power factor;	

11 BLACK BOX RECORDS

In main menu interface, select "3. Black Box Records", press  to enter black box records interface.

Enter black box record interface, press  and  to check every record; press  to return main menu interface.	
1: 2022-10-24 09:25:30	Record time of the first data;
2: 2022-10-28 10:07:18	Record time of the second data;
3: 2022-10-29 10:13:56	Record time of the third data;
4: 2022-10-30 11:45:20	Record time of the four data;
Close S2	Current selected event;
Press  to check one data of the current records; Press  and  to check every data of current records; Press  to return back to black box record interface.	
Closing S2	Record event;
22-10-28 10:07:18 +10s	Record time (60 time points between 50s before record event and 10s after the event occur)
S1 Available	S1 power status;
U1 (LN) 220 221 219V	S1 phase voltage;
F1 50.00Hz	S1 frequency;
Press  and  key to check S1 Voltage, S2 Voltage, Current and Power of current time point. Press  or  to exit the detailed data interface.	
Closing S2	Record event;
22-10-28 10:07:18 +10s	Record time point;
S1 Available	S1 power status;
U1 (LN) 220 221 219V	S1 phase voltage;
F1 50.00Hz	S1 frequency;
Closing S2	Record event;
22-10-28 10:07:18 +10s	Record time point;
S2 Available	S2 power status;
U2 (LN) 220 221 219V	S2 phase voltage;
F2 50.00Hz	S2 frequency;
Closing S2	Record event;
22-10-28 10:07:18 +10s	Record time point;
Amp 130 145 136A	Load current;
TkW 86 PF 1.00	Load active power and power factor;

Black box records max. 5 items. Every event records the status information during the 60s before and after the event occur. It records once per second. When record items is up to 5, new item will cover the newest record. The first item is the newest. Users can check each record by Confirm key and check the 60 detailed data status in each item by Up and Down key.

Record type: Action events during the close and open transfer in Auto mode.







Table 21 – Action Events are Ones at Below Time

No.	Action Event	Description
1	Opening	Opening in Auto mode;
2	Closing S1	S1 close in Auto mode;
3	Closing S2	S2 close in Auto mode;

12 HARMONIC ANALYSIS

Controller has harmonic analysis function for voltage and current, which can monitor harmonic distortion rate and 3-21 times harmonic component of voltage/current of all phases.

In main menu interface, select "4. Harmonic Analysis", and press  key to enter harmonic analysis interface.

Enter harmonic analysis page, press  and  key to select the voltage needed to analyze; press  to return main menu screen.	
>U1 Volt. Harmonic >U2 Volt. Harmonic >Current Harmonic	Harmonic analysis of S1 power 3 phases; Harmonic analysis of S2 power 3 phases; Harmonic analysis of load 3 phase current;
Press  to check harmonic analysis data of current phase; press  and  to check data of next phase; press  to return the previous menu.	
THDu-U1-A 0% 3-7 0 0 0% 9-13 0 0 0% 15-19 0 0 0% 21 0%	Harmonic distortion rate of U1 A phase voltage; 3-7 times harmonic display of U1 A phase voltage; 9-13 times harmonic display of U1 A phase voltage; 15-19 times harmonic display of U1 A phase voltage; 21 times harmonic display of U1 A phase voltage;

13 AUTO RESTORE TIME SETTING

In menu page, select "6 Auto Restore Time Set", press  to enter the setting interface.

When auto trans./auto restore and the voltage of main power is normal:	
Auto restore delay is due, the current time is greater than or equal to the start time but less than the stop time, the process of auto restore is performed.	
Auto restore delay is due, the auto restore process is performed when start time and stop time are equal.	
Waiting Time 00000min Start Time 00:00(h:m) Stop Time 00:00(h:m)	Auto restore delay time (min): (0-30000) min Start time (h): 0~23h, min: 0~59m Stop time (h): 0~23h, min: 0~59m

14 SWITCH OPERATION

14.1 MANUAL SWITCH OPERATION





Press  key, and manual status indicator is illuminated. Controller is in manual mode.

Table 22 – Manual Transfer Key

Icon	Function	Description
	S1 Close Key	Press this key and if load is disconnected, then S1 closes and load is supplied by S1.
	S2 Close Key	Press this key and if load is disconnected, then S2 closes and load is supplied by S2.
	Open Key	Press and load is disconnected.

14.2 AUTOMATIC SWITCH OPERATION

Press  key, and auto mode indicator becomes light and the controller is in the auto mode.

Under auto mode, the controller will switch automatically to ensure power supply for loading according to S1&S2 status, switch priority and Auto Trans./Restore status. The following illustrates the control logics by the example of "S1 Master", "S1 Mains S2 Gen".

14.2.1 AUTO TRANSFER AUTO RESTORE

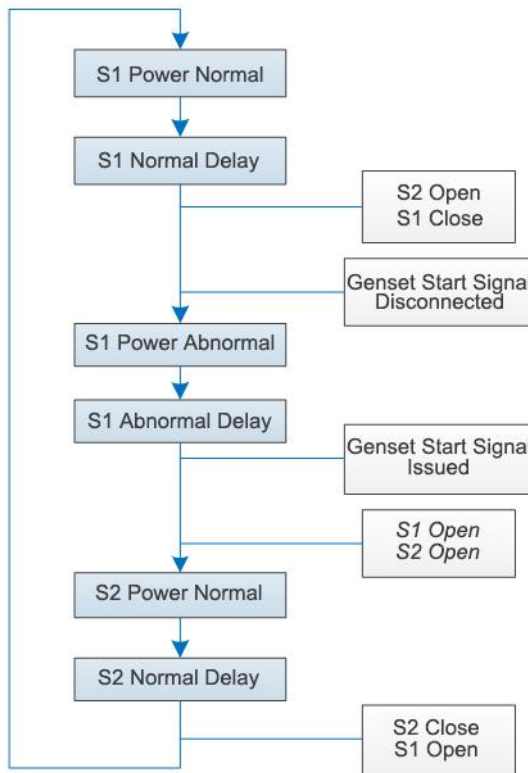

Fig. 3 – Auto Trans./Restore Diagram

14.2.2 AUTO TRANSFER NON RESTORE (MUTUAL BACKUP ACTIVE)

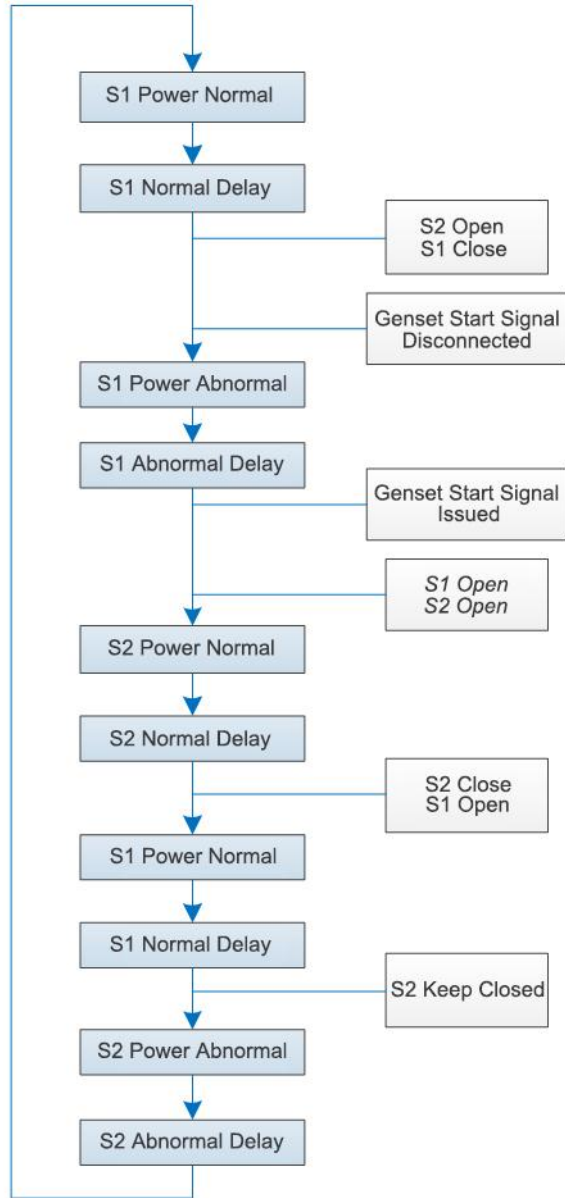

Fig. 4 – Auto Transfer Non Restore Diagram (Mutual Backup Active)

14.2.3 AUTO TRANSFER NON RESTORE (MUTUAL BACKUP INACTIVE)

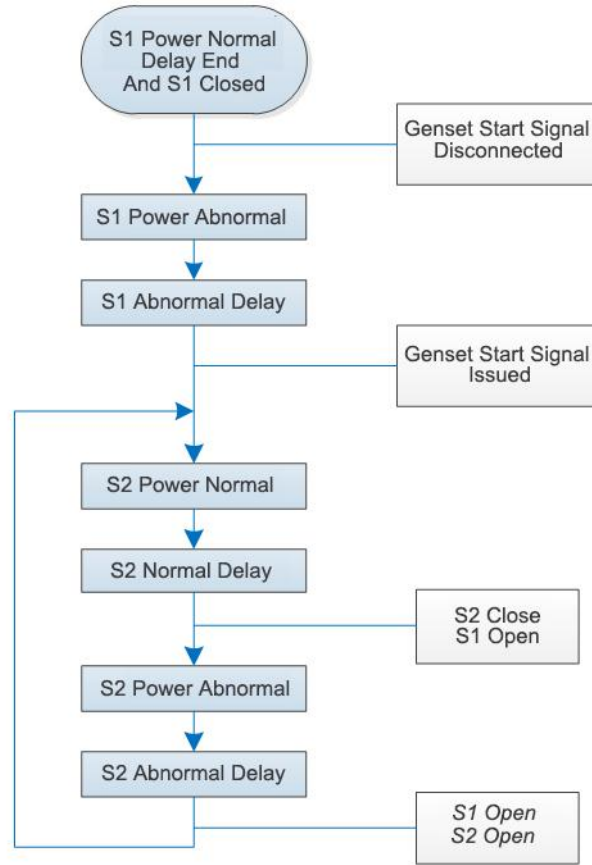

Fig. 5 – Auto Transfer Non Restore Diagram (Mutual Backup Inactive)

NOTE: Master power (S1) close needs to transfer to manual mode by close operation key, otherwise, in auto mode switch only transfers at the position of open and backup power (S2).

14.3 SYNCHRONIZING CLOSE

Synchronizing close is transferring current power side to the other power supply under normal condition of both S1 and S2. During this process synchronizing transfer is needed.

Parallel Mode: When the selected parallel mode is manual automatic parallel/manual parallel/automatic parallel or set the input port as manual automatic parallel/manual parallel/automatic parallel and the sync close function are active, when select non-parallel mode, sync. close function cannot be executed.

Sync. Volt Difference: Maximum volt difference between S1 and S2 at synchronization; if it is enabled, volt difference won't be detected in synchronizing process.

Sync. Freq. Difference: Maximum frequency difference between S1 and S2 at synchronization.

Sync. Phase Difference: Maximum phase difference between S1 and S2 at synchronization. Usually phase difference shall not be set too big. Otherwise, load impact will be too big at closing.

Fail To Sync Action: Warning alarm or fault alarm can be set; after sync failure, it continues waiting for sync until sync close is finished. For warning alarm when sync is completed or it exits from sync, alarm shall be cleared; for fault alarm, it needs alarm reset key to clear the alarm.

Transfer On Sync Fail: When this is enabled, after sync fails, non sync close will be conducted and no sync failure alarm shall be issued.

Fail To Sync Delay: Waiting time for sync; it shall issue sync failure alarm when it is overtime.

Breaker Feedback Time: Pulse time for synchronizing close/open; at the time of synchronizing transfer, sync close/open output delay starts; in the delay process if correct close status is detected, then stop the close/open pulse output; if after delay is over, correct close status still cannot be detected, close/open failure alarm shall be initiated.

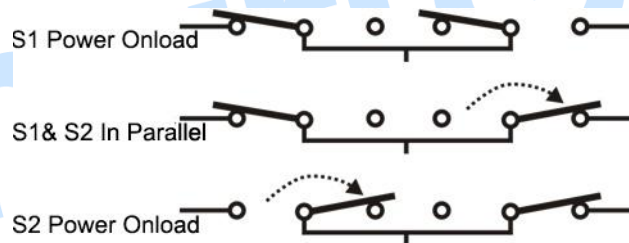
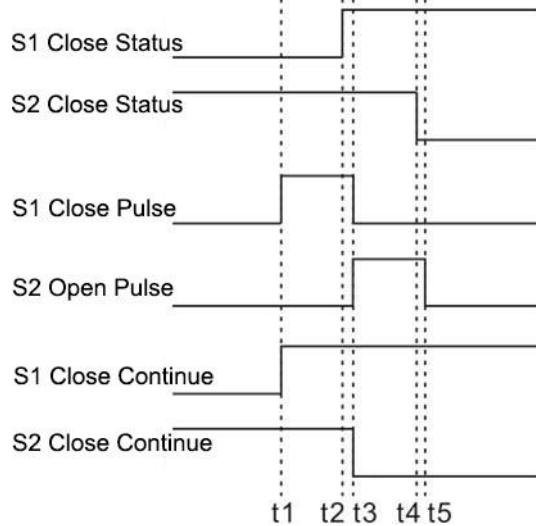

Fig. 6 – Sync Transfer Diagram

14.3.1 S1 SYNC CLOSE

S1&S2 power voltages are normal. S2 is on load, and S1 close pulse outputs. Until S1 close status is detected or delay is up to sync close/open detection time, disconnect S1 close pulse output. At the same time S2 open pulse outputs; until S2 open status is detected or delay is over sync close/open detection time, disconnect S2 open pulse outputs. In synchronizing process if close/open time is over sync close/open detection time, then close/open failure alarm is initiated.



- t1: S1 starts to sync. close;
- t2: S1 close signal is active;
- t3: execute S2 open;
- t4: S2 close signal is inactive;
- t5: S2 open ends;

Fig. 7 – S1 Sync Close Procedure Oscillogram

14.3.2 S2 SYNC CLOSE

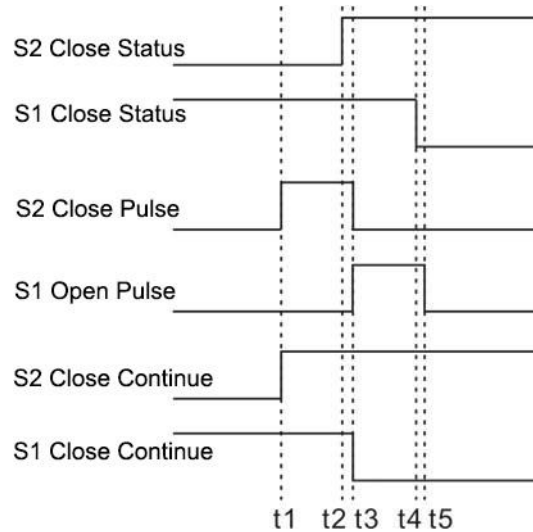

S1&S2 power voltages are normal. S1 is on load, and S2 close pulse outputs. Until S2 close status is detected or delay is up to sync close/open detection time, disconnect S2 close pulse output. At the same time S1 open pulse outputs; until S1 is opened or delay is over sync close/open detection time, disconnect S1 open pulse outputs. In synchronizing process if close/open time is over sync close/open detection time, then close/open failure alarm is initiated.



- t1: S2 starts to sync. close;
- t2: S2 close signal is active;
- t3: execute S1 open;
- t4: S1 close signal is inactive;
- t5: S1 open ends;

Fig. 8 – S2 Sync Close Procedure Oscillogram

14.3.3 MANUAL SYNC CLOSE

When it is manual mode, and S1&S2 power are normal, if S1 is closed, press S2  key and S2 closes synchronously. If S2 is closed, press S1  key, and S1 closes synchronously. In the process of waiting for sync, press close key again and sync close is stopped. If sync waiting is overtime, sync failure warning alarm is initiated; but it will continue waiting to sync, until sync is completed, or cancel sync close by pressing close key.

14.3.4 AUTO SYNC CLOSE

When it is auto mode and backup power is normal and backup is closed, master will sync close if master power recovers.

 **NOTE:** Controller is in auto mode, if failed to close or close inhibit occur in transferring process, corresponding switch won't execute close action, but execute other switch that can control close to supply for load. If failed to open occurs, switch won't execute action.

 **HAZARD:** When controller is in auto mode, direct switch operation is inhibited! when sync close is active, S1 and S2 may be in parallel. If system is S1 Mains S2 Mains, please do the locking on switch side to prevent S1 and S2 close at the same time. Otherwise, it may cause switch or lines burning or personal injury if it is serious.

14.4 LOCAL MODE RUNNING

The local mode is controlled by the programmable input port (external knob). When the local mode is active, the controller only displays “not control”, the output port of electrical interlock release will not output, electrical interlock is active (Parallel Inhibit).

15 ATS SUPPLY POWER

15.1 DC SUPPLY

Configure switch power supply to DC supply. When switch is DC supply, it is considered that switch can be transferred at any time, including the time of S1/S2 power off.

15.2 AC SUPPLY

If AC supply is used, ATS power is supplied by controller smartly. If there is only one voltage normal, it can ensure ATS power supply normal and make it normally transfer.

Please confirm the following parameters when AC supply is used:

- Switch supply type is AC supply;
- The upper and lower thresholds of AC supply voltage meet the requirements;

ATS power supply is phase voltage (A-N):

Set AC supply rated voltage to 220V, and set AC supply voltage lower limit to 70% rated, upper limit to 130% rated.

The internal connection is as below:

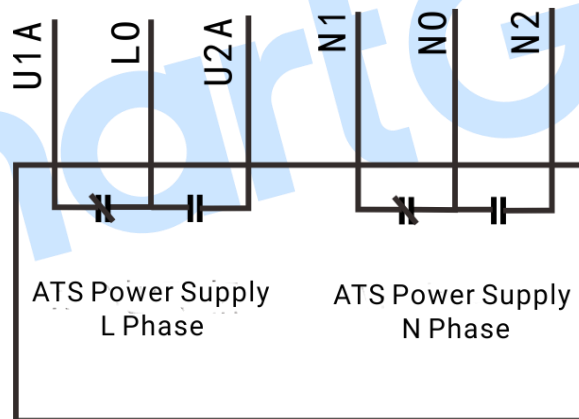

Fig. 9 – ATS Power Phase Voltage Supply

16 NEL CONTROL

16.1 ILLUSTRATION

Non-essential Load is NEL for short, which refers to the load that can be unloaded first when genset power is not enough.

Controller can control 3 ways of NEL trip and the essentiality is: NEL 3>NEL 2>NEL 1.

16.2 AUTOMATIC OPERATION

When NEL auto trip is enabled: If genset power has exceeded NEL trip value, after trip delay NEL1 will trip for the earliest, and next is NEL2, NEL3;

When NEL auto reconnection is enabled: If genset power has fallen below the auto reconnection set value, after the auto reconnection delay NEL3 will be reconnected for the earliest, and next is NEL2, NEL1;

t1: NEL Trip Delay
t2: Reconnection Delay

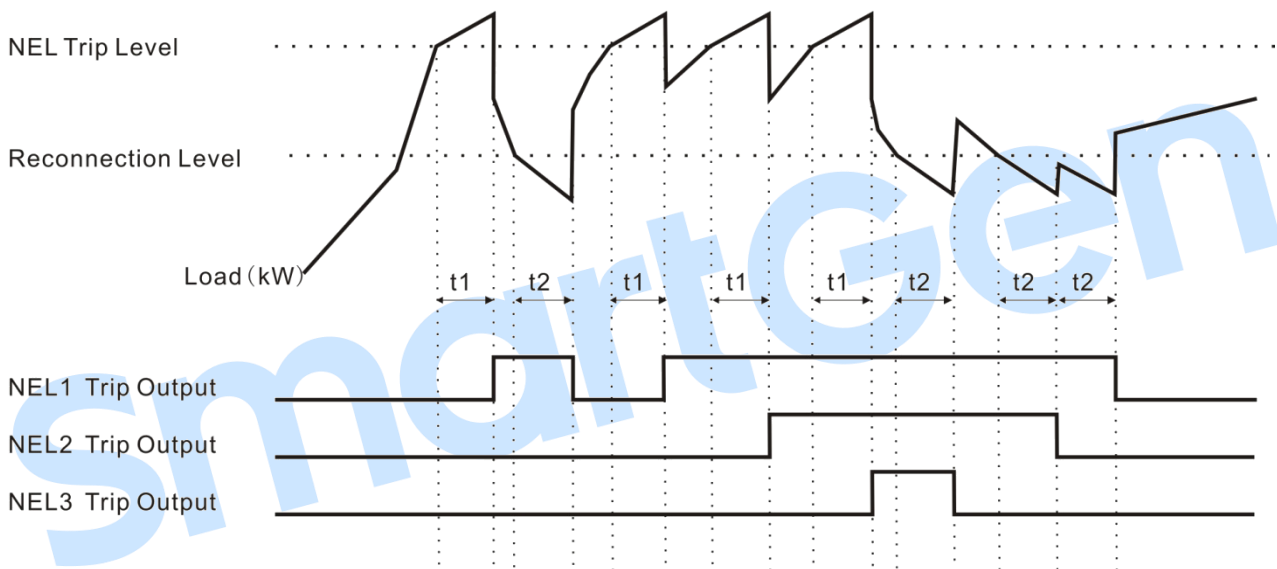

Fig. 10 – NEL Control Time Sequence

16.3 MANUAL TRIP

If NEL manual trip input is active (falling edge is active), NEL1 will trip without delay; If NEL manual trip input is active again, NEL2 will trip; If NEL manual trip input is active for the third time, NEL3 will trip. During this process, the controller does not detect if the genset power has exceeded the NEL trip value or not.

If NEL manual reconnection input is active, NEL3 will be reconnected without delay; If NEL manual reconnection input is active again, NEL2 will reconnect; If NEL manual reconnection input is active for the third time, NEL1 will reconnect. During this process, the controller detects the genset power: if the genset power has fallen below the NEL reconnection value, then the input is active; if it doesn't, the input is deactivated.

NOTE: When auto trip and auto reconnection are enabled, manual trip is still active.

17 COMMUNICATION CONFIGURATION

17.1 ILLUSTRATION

HAT660 series controller has RS485 serial port, USB communication port, ETHERNET communication port. Among them RS485 and ETHERNET communication port are allowed to connect the local area network openly. They both use Modbus protocol via PC or system software of data collecting, which provides a simple and practical dual power switching management to factories, telecom, industrial and civil buildings, which achieves “remote control, remote measuring, remote communication” functions.

More information of Communication Protocol, refer to “HAT660 Communication Protocol”.

NOTE: ETHERNET communication is only applicable for HAT660BI and HAT660S.

17.2 RS485 COMMUNICATION PORT

Communication Protocol: Modbus-RTU

Communication Parameters

Module address 1 (range: 1-254)
 Baud rate 9600 bps(2400/4800/9600/19200bps)
 Data bit 8bit
 Parity bit None (None, Odd Parity, Even Parity)
 Stop bit 2bit (1 bit or 2-bits)

17.3 USB COMMUNICATION PORT

D form USB communication port can be used to connect PC test software to configure parameters and at the same time it can be used to module software upgrade.

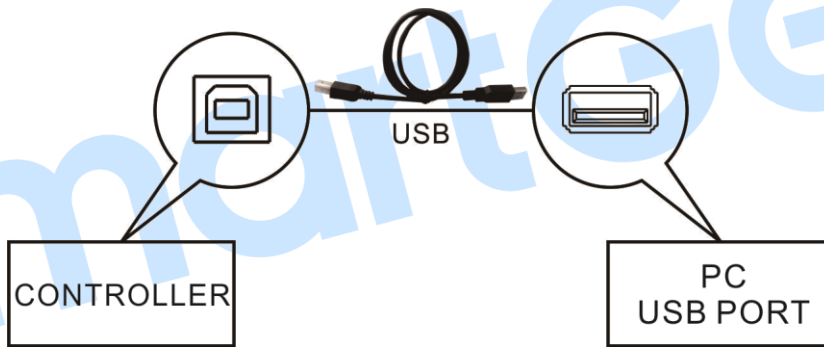

Fig. 11 – USB Connection

17.4 ETHERNET COMMUNICATION PORT

Communication protocol: Modbus TCP/IP

Self-adaptable 10/100Mbps working mode, not supportive of autopolarity inversion function. Users need to use direct connecting wire to connect with converter or router, use cross wire to connect with terminal device (e.g. PC). If the device connecting with controller has autopolarity inversion function, then users can use any wire to connect with the device.

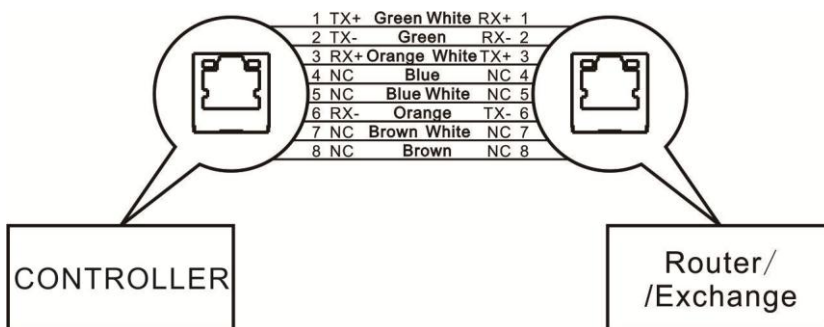

Fig.12 – Direct Connection Between Controller and Router

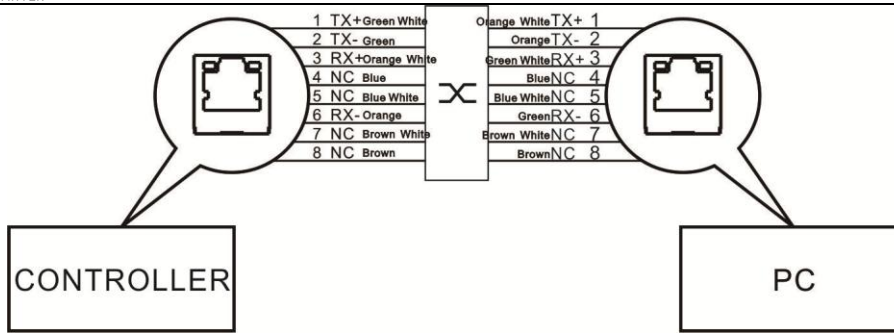

Fig. 13 – Cross Connection Between Controller and PC

NOTE: Generally direct wiring is enough to connect controller and PC.

18 TERMINAL DESCRIPTION

18.1 CONTROLLER TERMINAL DESCRIPTION

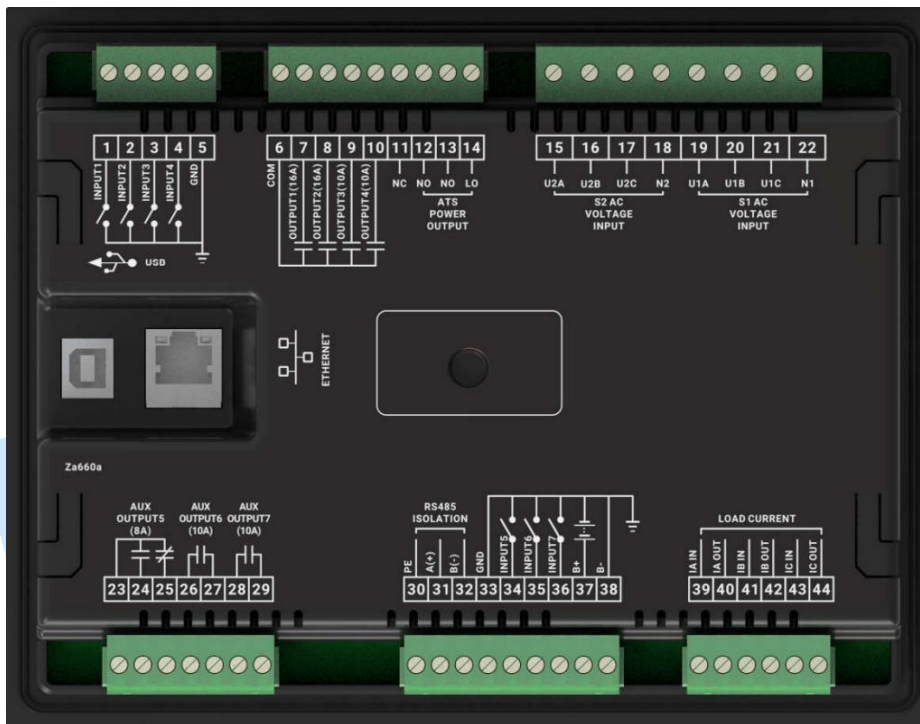

Fig. 14 – Controller Back Panel

Table 23 – Port Function Description

Pin	Items	Description	Notes
1	Aux. input 1	User defined	Default: S1 close input GND connected is active;
2	Aux. input 2		Default: S1 switch trip input GND connected is active;
3	Aux. input 3		Default: S2 close input GND connected is active;
4	Aux. input 4		Default: S2 switch trip input GND connected is active;
5	GND	Input common	
6	COM	Input common	
7	Aux. output 1	Voltage free relay N/O output	Default: S1 close control Capacity 16A 250VAC Connect to output port COM.
8	Aux. output 2	Voltage free relay N/O output	Default: S2 close control

Pin	Items	Description	Notes
			Capacity 16A 250VAC Connect to output port COM.
9	Aux. output 3	Voltage free relay N/O output	Default: S1 open control Capacity 10A 250VAC Connect to output port COM.
10	Aux. output 4	Voltage free relay N/O output	Default: S2 open control Capacity 10A 250VAC Connect to output port COM.
11	NC	Null	
12	NO	ATS power supply N	Provide power supply for ATS.
13	NO		
14	LO		
15	U2A	S2 AC 3P4W voltage input	For single phase, only connect U2A, N2.
16	U2B		
17	U2C		
18	N2	S1 AC 3P4W voltage input	For single phase, only connect U1A, N1.
19	U1A		
20	U1B		
21	U1C		
22	N1		
23	Aux. output 5	Common	Default: genset start output Capacity 8A 250VAC
24		NO	
25		NC	
26	Aux. output 6	Voltage free relay N/O output	Default: self-defined combination 1 output; Capacity 10A 250VAC
27			
28	Aux. output 7	Voltage free relay N/O output	Default: common alarm output; Capacity 10A 250VAC
29			
30	PE	GND Connected terminal for communication port	
31	485A	RS485 communication port	
32	485B		
33	GND	Input common port	
34	Aux. input 5	User-defined input port	Default: forced open GND connected is active;
35	Aux. input 6		Default: switch trip GND connected is active;
36	Aux. input 7		Default: not used GND connected is active;
37	B+	Connects genset start battery positive when genset is started;	DC positive input (8-35)V, controller power
38	B-	Connects genset start battery negative;	Internal connect to GND.
39	IA Input	Input of CT Secondary phase A current	Rated current 5A Only suitable for HAT660BI/HAT660S
40	IA Output		
41	IB Input	Input of CT Secondary phase B current	
42	IB Output		
43	IC Input	Input of CT Secondary phase C current	
44	IC Output		
USB	USB	D form USB communication port	Able to connect PC to configure parameters and software upgrade;
ETHERNET	Ethernet port	Used for communication	Only suitable for HAT660BI/HAT660S;

18.2 CONTROLLER POWER SUPPLY DESCRIPTION

18.2.1 DC SUPPLY

HAT660B/HAT660BI/HAT660S controller are all DC supply fitted, with supply voltage range (8-35)VDC.

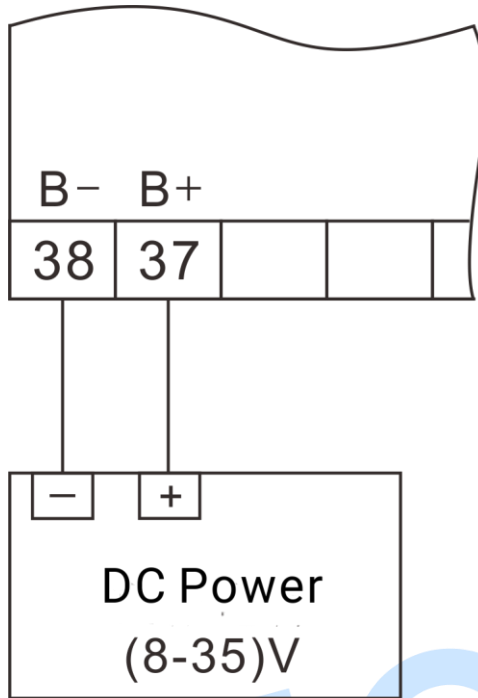

Fig. 15 – DC Supply

18.2.2 AC SUPPLY

HAT660B/HAT660BI/HAT660S controllers are AC supply fitted. Controllers are supplied by the AC sampling terminals of the two circuits.

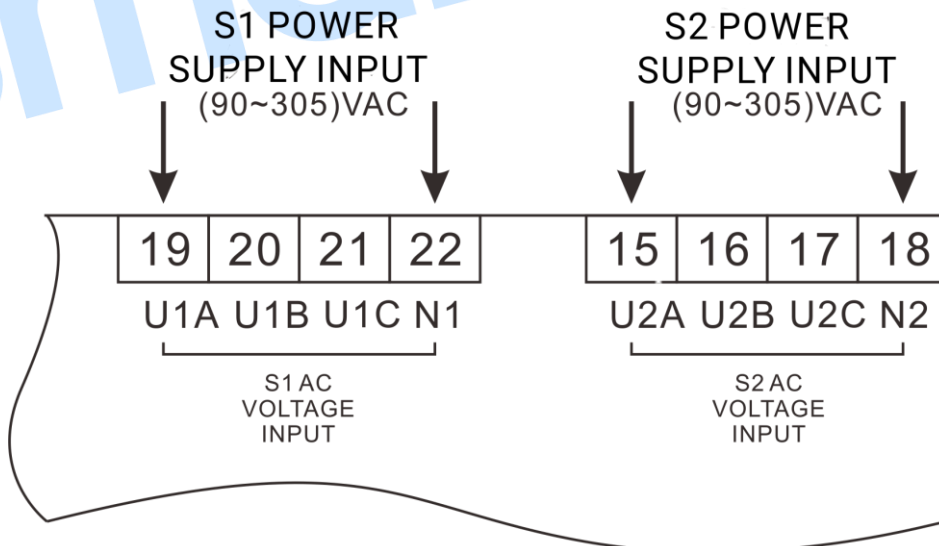

Fig. 16 – AC Supply

18.3 RS485 CONNECTION DESCRIPTION

RS485 and Adapter connection is as below:

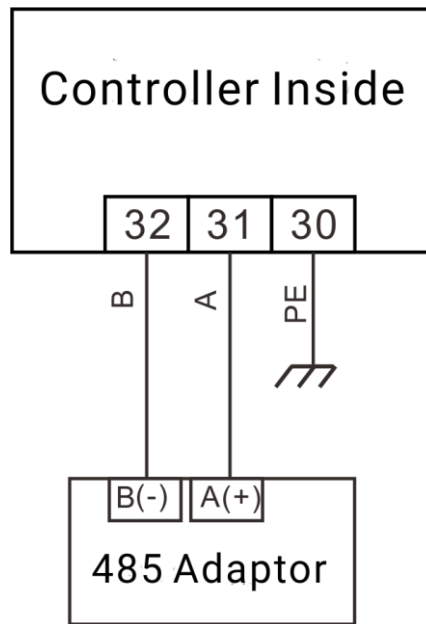

Fig. 17 – RS485 Connection

19 TYPICAL APPLICATION WIRING DIAGRAM

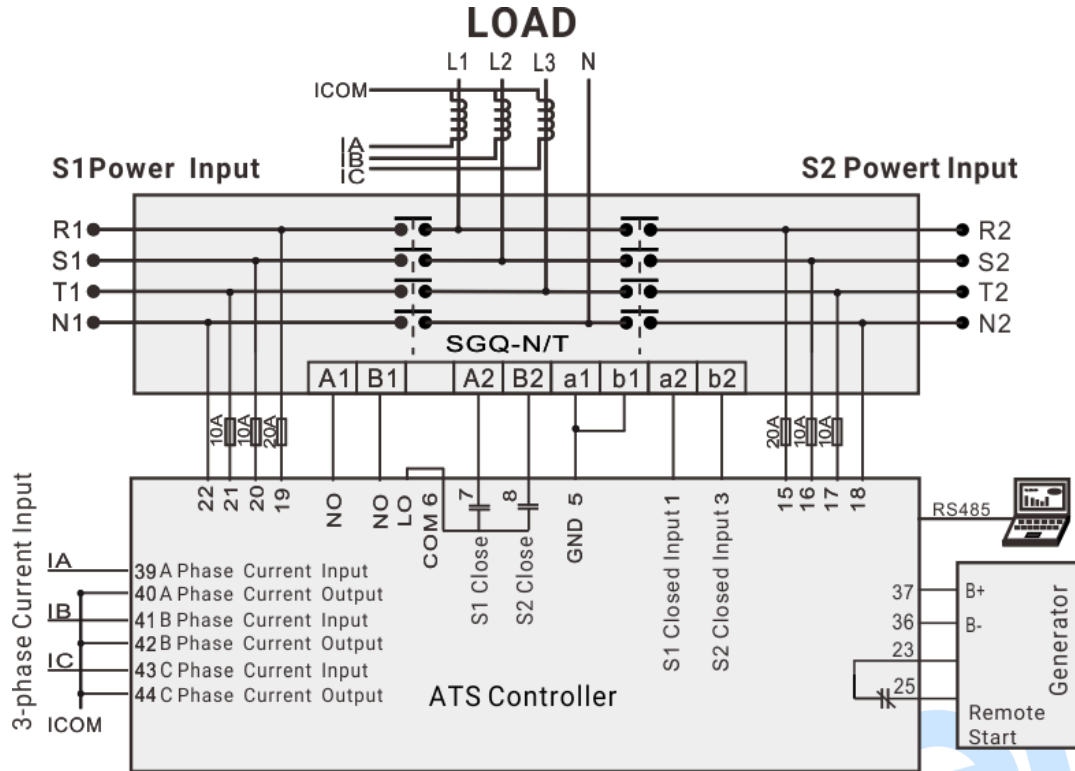

Fig. 18 – SGQ-N/T Application Diagram

Table 24 – Corresponding Settings

Part of Parameter Settings	
Switch Type Setting	PC two-stage
Aux. Input 1	S1 Closed Signal Input
Aux. Input 3	S2 Closed Signal Input
Aux. Output 1	S1 Switch Close Control
Aux. Output 2	S2 Switch Close Control
Aux. Output 5	Genset Start Output

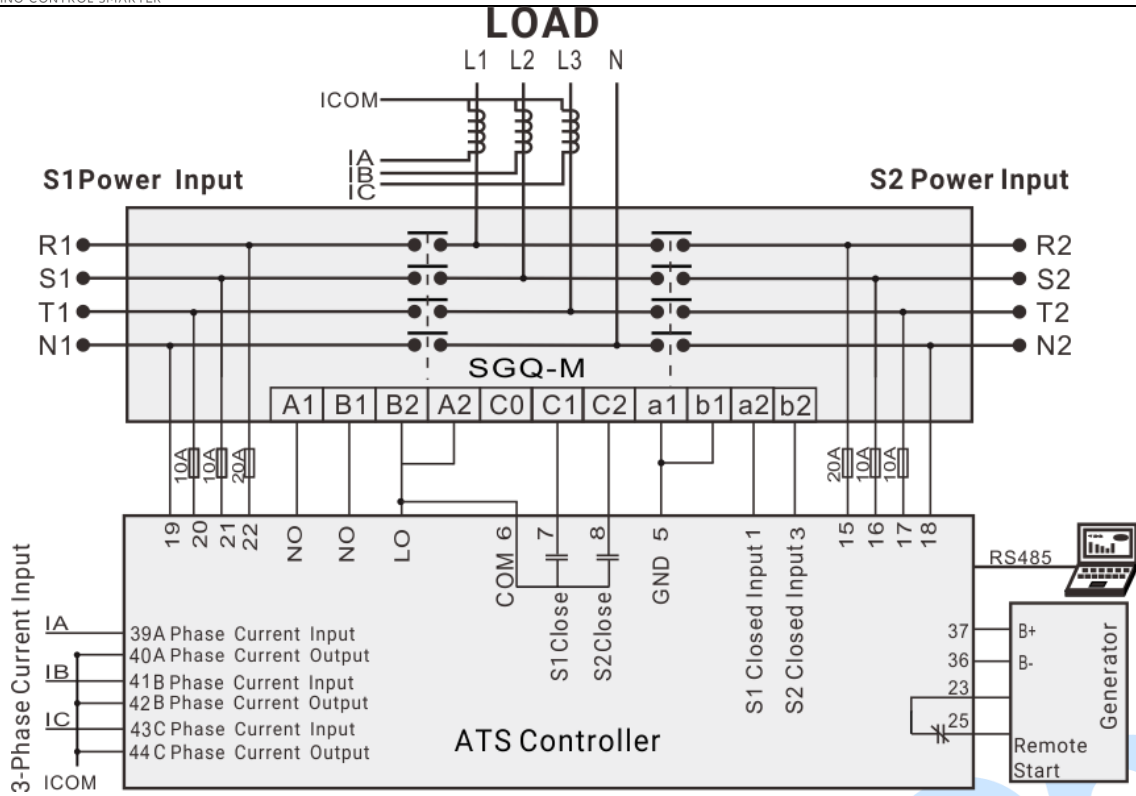

Fig. 19 – SGQ-M Application Diagram

Table 25 – Corresponding Settings

Part of Parameter Settings	
Switch Type Setting	PC two-stage
Aux. Input 1	S1 Closed Signal Input
Aux. Input 3	S2 Closed Signal Input
Aux. Output 1	S1 Switch Close Control
Aux. Output 2	S2 Switch Close Control
Aux. Output 5	Genset Start Output

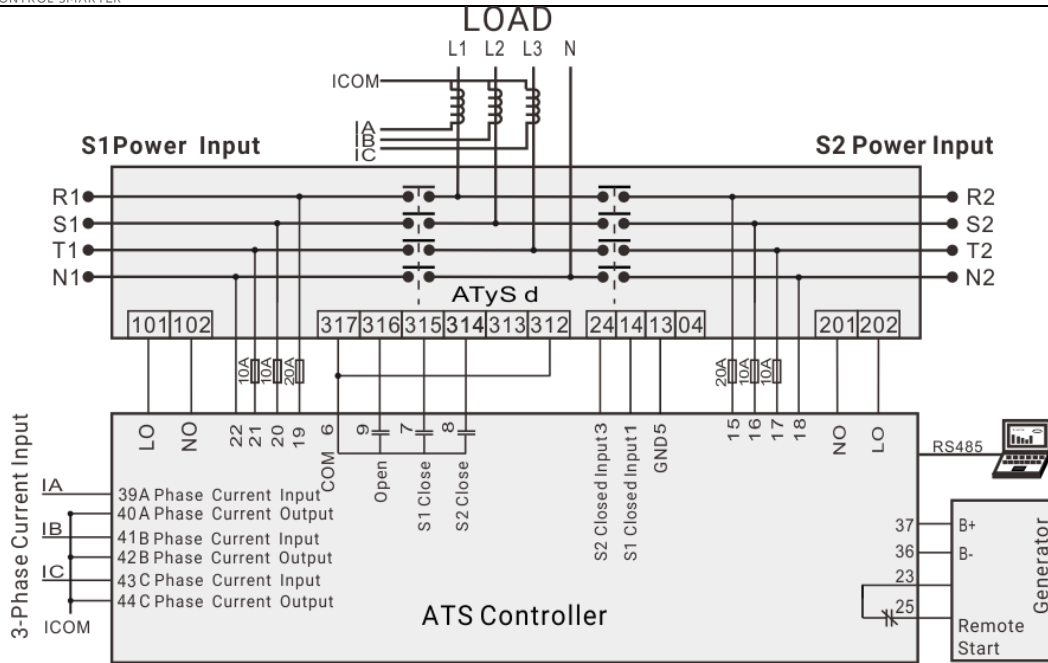

Fig. 20 – AtySd Application Diagram

Table 26 – Corresponding Settings

Part of Parameter Settings	
Switch Type Setting	PC three-stage
Aux. Input 1	S1 Closed Signal Input
Aux. Input 3	S2 Closed Signal Input
Aux. Output 1	S1 Switch Close Control
Aux. Output 2	S2 Switch Close Control
Aux. Output 3	S1 Switch Open Control
Aux. Output 5	Genset Start Output

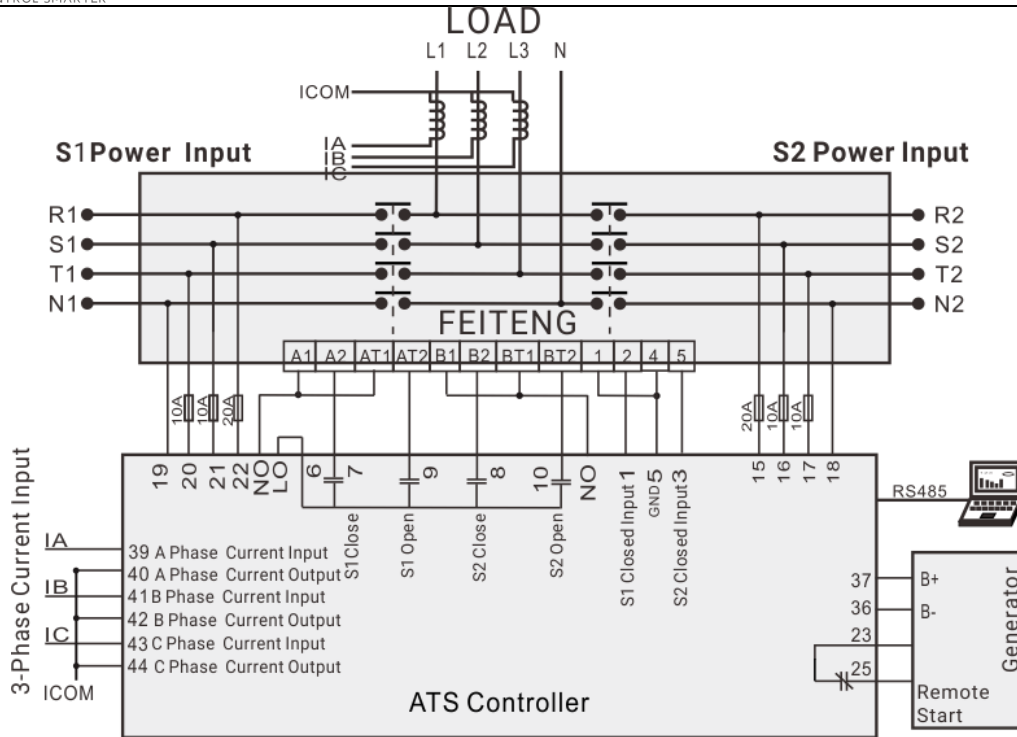

Fig. 21 – FEITENG Application Diagram

Table 27 – Corresponding Settings

Part of Parameter Settings	
Switch Type Setting	CB/CC Class
Aux. Input 1	S1 Closed Signal Input
Aux. Input 3	S2 Closed Signal Input
Aux. Output 1	S1 Switch Close Control
Aux. Output 2	S2 Switch Close Control
Aux. Output 3	S1 Switch Open Control
Aux. Output 4	S2 Switch Open Control
Aux. Output 5	Genset Start Output

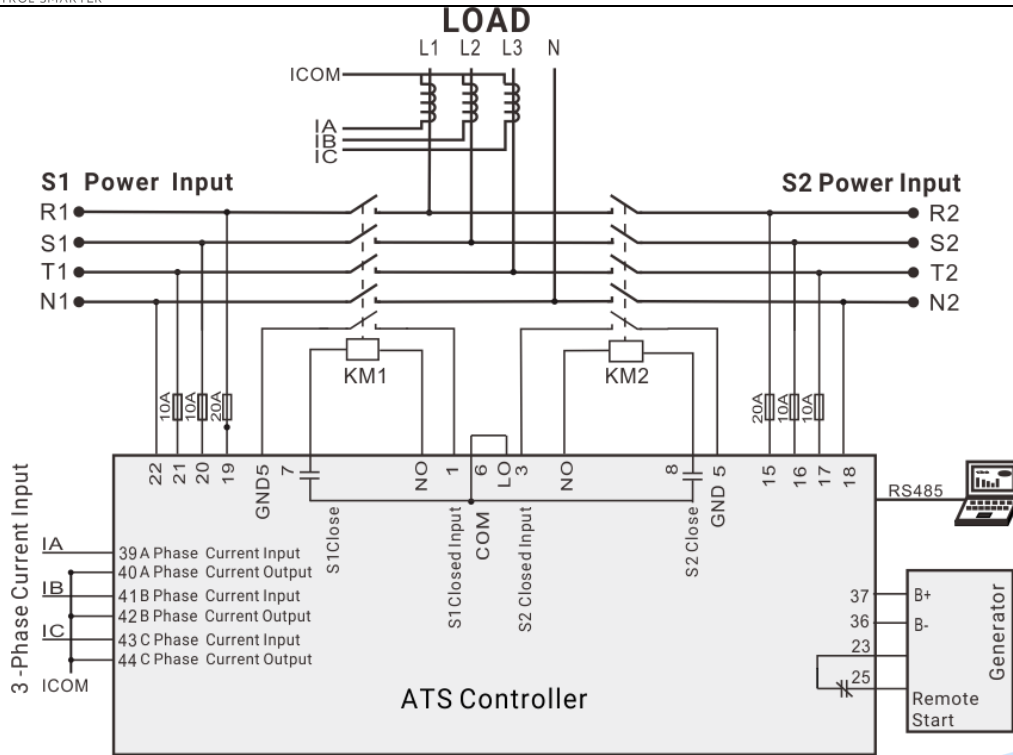

Fig. 22 – Contactor Application Diagram

Table 28 – Corresponding Settings

Part of Parameter Settings	
Switch Type Setting	CB/CC Class
Aux. Input 1	S1 Closed Signal Input
Aux. Input 3	S2 Closed Signal Input
Aux. Output 1	S1 Switch Close Control
Aux. Output 2	S2 Switch Close Control
Aux. Output 3	S1 Switch Open Control
Aux. Output 5	Genset Start Output
Close Continuous Output	Enable

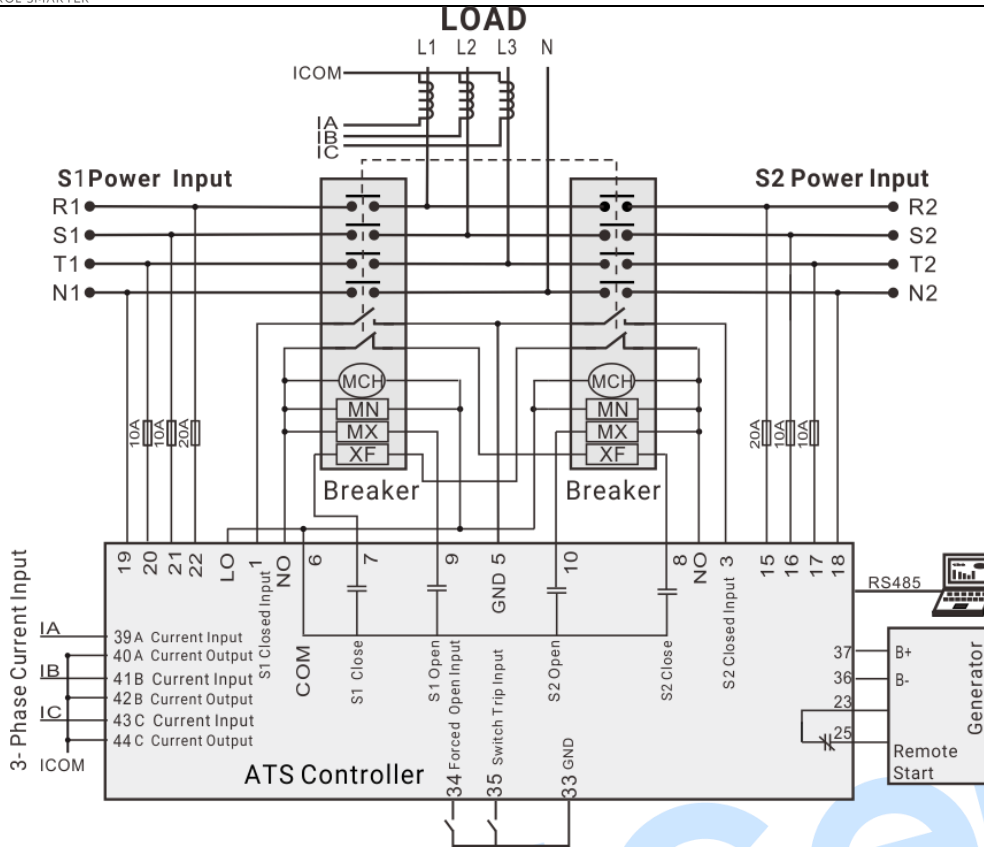

Fig. 23 – Breaker Application Diagram

Table 29 – Corresponding Settings

MCH: Energy-save Motor; MN: Undervolt Trip; MX: Open Coil; XF: Close Coil;

Part of Parameter Settings	
Switch Type Setting	CB/CC Class
Aux. Input 1	S1 Closed Signal Input
Aux. Input 3	S2 Closed Signal Input
Aux. Input 5	Forced Open Input
Aux. Input 6	Switch Trip Input
Aux. Output 1	S1 Switch Close Control
Aux. Output 2	S2 Switch Close Control
Aux. Output 3	S1 Switch Open Control
Aux. Output 4	S2 Switch Open Control
Aux. Output 5	Genset Start Output

NOTE 1: Above are HAT660 series function application diagrams, among which HAT660B doesn't have current sampling input, please neglect the current part of the diagrams.

20 INSTALLATION

The controller is panel installation designed and needs to be fixed by clips.

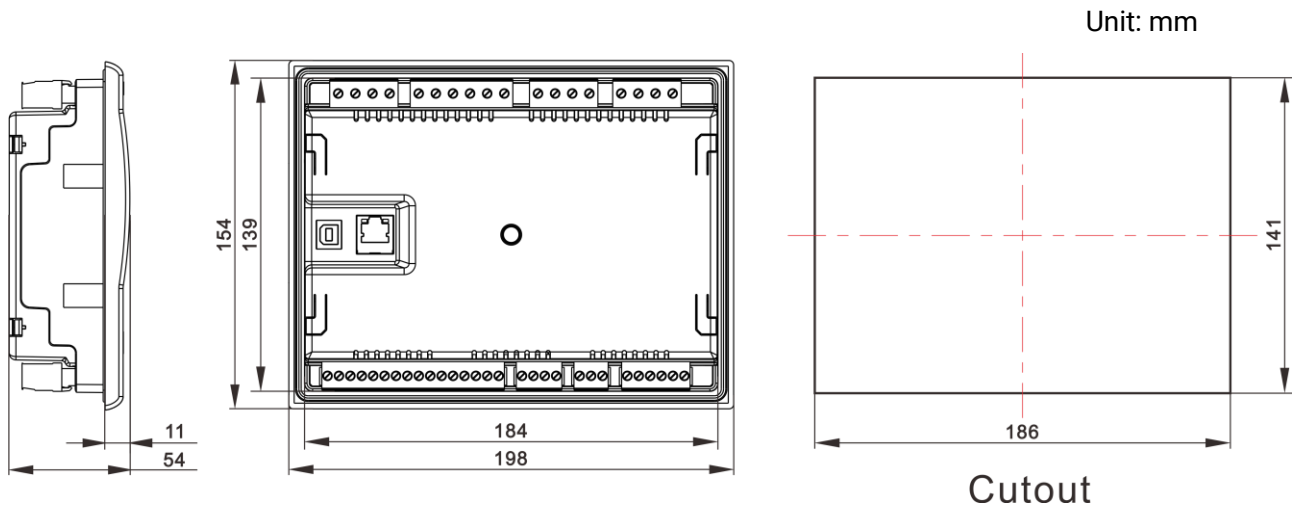

Fig. 24 – Case Dimensions and Panel Cutout

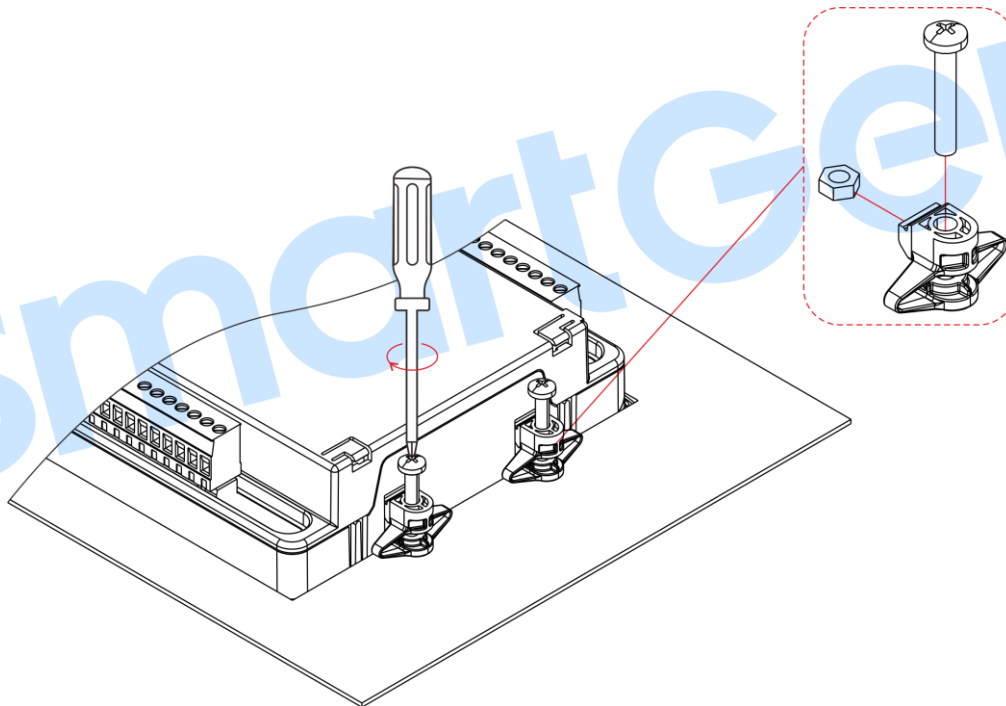

Fig. 25 – Clip Installation Illustration

NOTES:

CAUTION: Risk of electric shock. Please cut off the power of the controller before maintenance.

WARNING: Risk of electric shock. Do not remove the rear shell of the controller. There are no parts inside the controller for maintenance.

WARNING: When there is current in the primary circuit of the CT, the secondary circuit of the CT is not allowed to open.

Table 30 – Fault Finding

Fault Symptom	Possible Remedy
Controller no response	Check DC supply voltage; Check DC fuse; Check AC power;
RS485 communication failure	Check whether the RS485 is wrong connected between negative and positive. Check whether the RS485 adapter is abnormal. Check whether the parameter settings in the module addresses are incorrect.
ETHERNET communication failure	Check network communication is enabled or not; Check whether controller IP address, Gateway etc. are correctly set; Check whether network wires are correctly connected;
Programmable output error	Check programmable output connections, pay attention to Normally opened and closed; Check the output parameters settings and output types;
Programmable input abnormal	Check whether the input ports are GND connected when they are active; Ensure they are hung up when they are inactive; (NOTE: The input will be possibly destroyed when connected with over high voltage.) Check the input function settings and input active types in the parameter settings;
ATS transfer abnormal	Check ATS; Check the connection wire between controller and switch; Check whether switch type setting is in accordance with switch; Check ATS power settings and connection wires;
Genset start control abnormal	Check system type settings; Check output function settings and output types; Check start/stop function settings of all items.