

SmartGen

MAKING CONTROL SMARTER

CMM366A-4G

CLOUD MONITORING COMMUNICATION MODULE

USER MANUAL



郑州众智科技股份有限公司
SMARTGEN(ZHENGZHOU)TECHNOLOGY CO.,LTD.

SmartGen Registered trademark

No. 28 Xuemei Street, Zhengzhou, Henan, China

Tel: +86-371-67988888/67981888/67992951

+86-371-67981000 (overseas)

Fax: +86-371-67992952

Web: www.smartgen.com.cn/

www.smartgen.cn/

Email: sales@smartgen.cn

All rights reserved. No part of this publication may be reproduced in any material form (including photocopying or storing in any medium by electronic means or other) without the written permission of the copyright holder.

SmartGen reserves the right to change the contents of this document without prior notice.

Table 1 Software Version

Date	Version	Note
2017-12-25	1.0	Original release.
2022-07-14	1.1	Update company logo and manual format.
2023-08-09	1.2	Update description of RS485 access to 120Ω resistor.

CONTENT

1	OVERVIEW.....	4
2	PERFORMANCE AND CHARACTERISTICS.....	4
3	SPECIFICATION	5
4	PANEL AND TERMINAL DESCRIPTION.....	6
4.1	PANEL INDICATOR AND BUTTONS.....	6
4.2	GPRS	7
4.3	GPS.....	7
4.4	SIM INSTALLATION	7
4.5	RS485.....	8
4.6	RS232.....	9
4.7	LINK.....	9
4.8	USB HOST	9
4.9	USB DEVICE	10
4.10	TERMINAL	10
5	PROGRAMMABLE PARAMETERS.....	11
5.1	CONTENTS AND SCOPES OF PARAMETERS	11
5.2	PC CONFIGURATION INTERFACE	13
6	SYSTEM DIAGRAM	14
7	CASE DIMENSION AND INSTALLATION.....	15
8	FAULT FINDING	16
9	PACKING LIST.....	16

1 OVERVIEW

CMM366A-4G Cloud Monitoring Communication Module is 4G GPRS wireless network communication protocol switch module which can achieve genset (with SCI) connect to Internet. After logging into cloud server, module will receive corresponding genset controller communication protocol from cloud server. And the module gains genset data via RS485 port, USB port, LINK port or RS232 port. Then the module transmits the data to corresponding cloud server via 4G wireless network for achieving user's real-time monitoring to running status and searching of running records via APP (IOS or Android) and pc terminal devices.

CMM366A-4G module not only can achieve genset monitoring but also can insert some digital alarm input/output signal to achieve monitoring of generator room entrance guard, guard against theft and fire facilities.

CMM366A-4G module, which has GPS locate function, can upload gained longitude, latitude and altitude to corresponding cloud server.

2 PERFORMANCE AND CHARACTERISTICS

- Connect to cloud server via 4G wireless network, one genset to one monitoring;
- Multiple ports for communication with genset control module: RS485, RS232, LINK and USB (Host); can monitor great majority genset control modules of international first-class brands;
- Widely power supply: DC (8~35)V, can direct use genset built-in battery;
- With ARM-based 32-bit SCM, high integration of hardware and strong programming ability;
- With GPS location function to achieve gain location information and locate genset;
- Take JSON network data communication protocol, upload real-time data variation and take compression algorithm to vastly reduce network flow at the same time;
- When alarm occurs it can upload data to server immediately;
- 2 auxiliary digital input ports which can receive external alarm signal;
- 1 auxiliary relay output ports which can output various of alarm signal;
- Power and multiple communication status indicators on front panel that working status is clear at a glance;
- Lamp test function;
- Parameter adjust function: users can adjust parameters via USB port;
- Take standard π -type 35mm guide-rail installation or screw-fixed installation that the module can be installed in the genset control box;
- Modular design, self extinguishing ABS plastic shell, light weight, compact structure with easy installation.

3 SPECIFICATION

Table 2 Technical Data

Items	Contents
Operating Voltage	DC 8.0V~35.0V, continuous power supply.
Power Consumption	Standby: ≤2W Working: ≤5W
Digital Input	Digital Input, connect (B-) is active.
Relay Output	1A DC30V Volts free output
USB Host	A-type USB female port
RS485	Isolated type
RS232	General type
LINK	SmartGen exclusive port
USB Device	B-type USB female port
GPRS Port	Standard SMA port (female), SMA port (male) for antenna
GPS Port	Standard SMA port (female), SMA port (male) for antenna, active antenna
Wireless Network	LTE-TDD/LTE-FDD/HSPA+/TD-SCDMA/EVDO GSM/GPRS/EDGE
Case Dimensions	72.5mmx105mmx34mm
Working Temperature	(-25~+70)°C
Working Humidity	(20~93)%RH
Storage Temperature	(-25~+70)°C
Weight	0.15kg

4 PANEL AND TERMINAL DESCRIPTION

4.1 PANEL INDICATOR AND BUTTONS

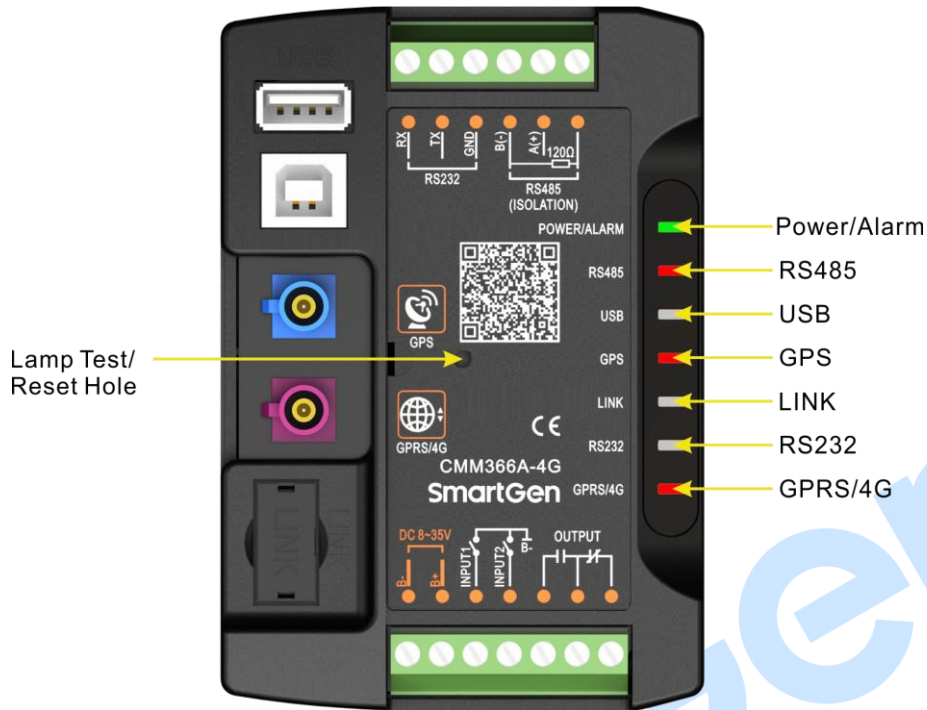

Fig.1 CMM366A-4G Front Panel Diagram

Table 3 Indicators Description

Icon	Note
POWER/ALARM	Green LED Light: Power supply normal indicator; Red LED Light: Common alarm indicator.
RS485(Red)	Normally Extinguish: RS485 disabled; Normally Light: Communication fail; Blink: Communication normal.
USB(Red)	Normally Extinguish: USB(Host) disabled; Normally Light: Communication fail; Blink: Communication normal.
GPS(Red)	Normally Extinguish: GPS disabled; Normally Light: GPS not gained satellite signal; Blink: GPS gained satellite signal.
LINK(Red)	Normally Extinguish: Disabled; Normally Light: Communication fail; Blink: Communication normal.
RS232(Red)	Normally Extinguish: RS232 disabled; Normally Light: Communication fail; Blink: Communication normal.
GPRS/4G(Red)	Extinguish: CMM366A-4G login with server unsuccessfully; Light: Login with server successfully; Blink: Real-time communication normal.

Lamp test/Reset:

Press this button for 1s, all the LEDs are illuminated; press for 10s, reset the module to default and all the LEDs blink for 3 times.

NOTE: After reset the module, parameters need to re-configured via PC software. Please operate cautiously.

4.2 GPRS

Connect GPRS antenna to GPRS/4G port.

Antenna: 50Ω/SMA female.

4.3 GPS

GPS enabled, connect GPS antenna to CMM366A-4G.

NOTE: GPS antenna needs to be placed to open outdoors, otherwise location information may not accurate or cannot be gained.

Antenna: 50Ω/SMA female, active antenna.

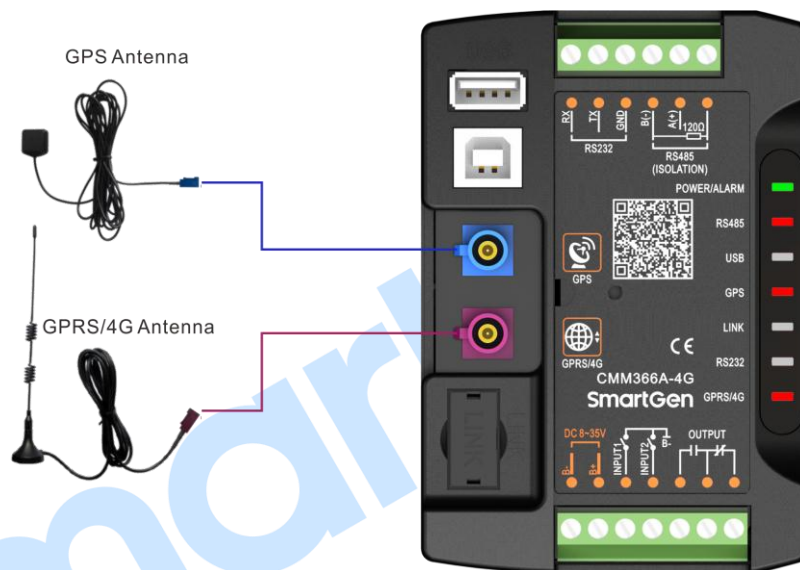

Fig.2 CMM366A-4G Antenna Connection

NOTE: GPRS antenna and GPS antenna cannot be connected reversely.

4.4 SIM INSTALLATION

Insert 4G, 3G or 2G SIM card. CMM366A-4G will connect to servers via wireless mobile network.

NOTE: 4G GPRS wireless network is supported. Use standard SIM card (25mmX15mm); GPS indicator and GPRS indicator blink in the same time, which means SIM card hasn't been inserted or bad contacts.

After removing the head cover, the installation steps are as below:

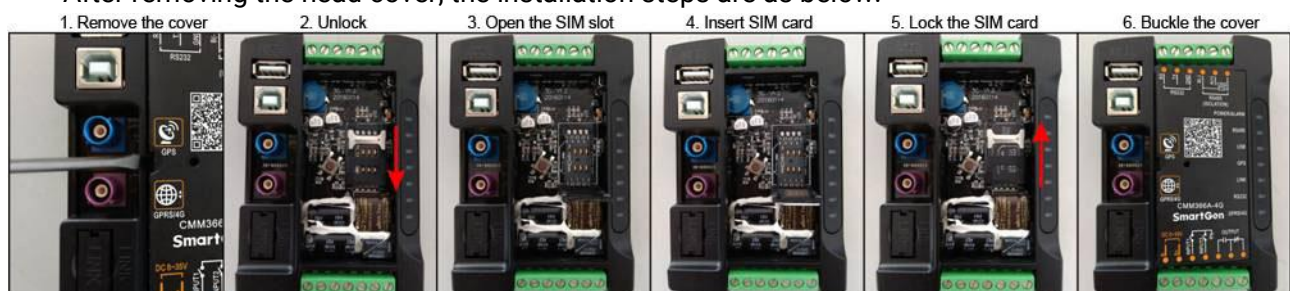

Fig.3 SIM Card Installation Steps

4.5 RS485

Receive genset data information by connecting module RS485 port with genset controller RS485 port.

If communication is abnormal, 120Ω terminal resistance is recommended. If 120Ω resistor is required, please short connect A(+) of RS485 port on CMM366A-4G and 120Ω.

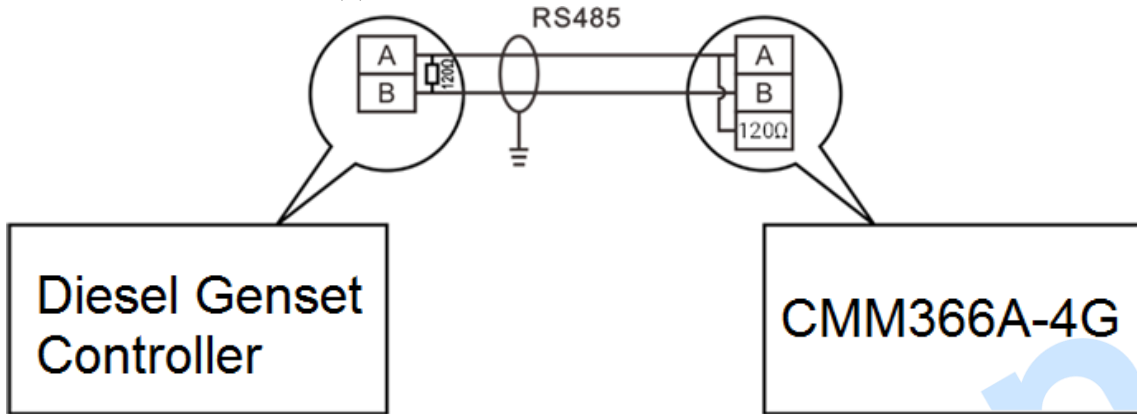

Fig.4 RS485 Connection



Fig.5 RS485 Access to 120Ω Resistor

4.6 RS232

Receive genset data information by connecting module RS232 port with genset controller RS232 port.

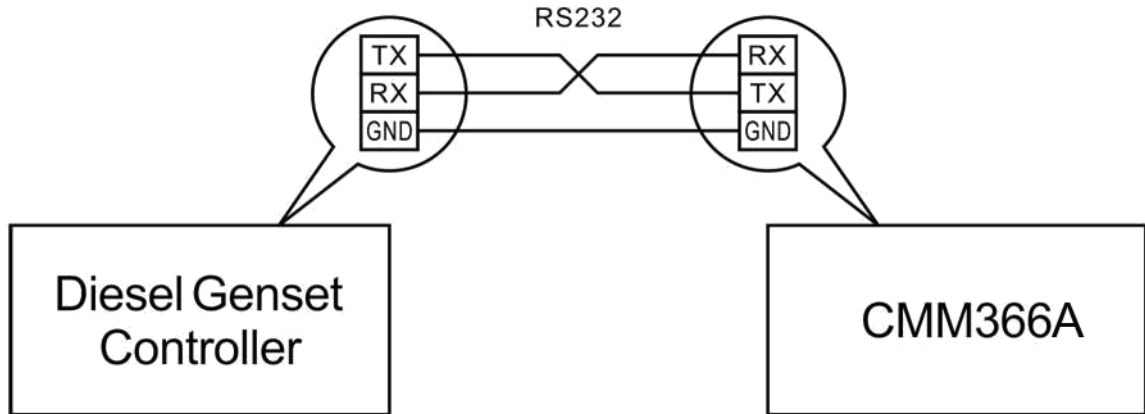

Fig.6 RS232 Connection

4.7 LINK

Receive genset data information by connecting module LINK port with genset controller LINK port.

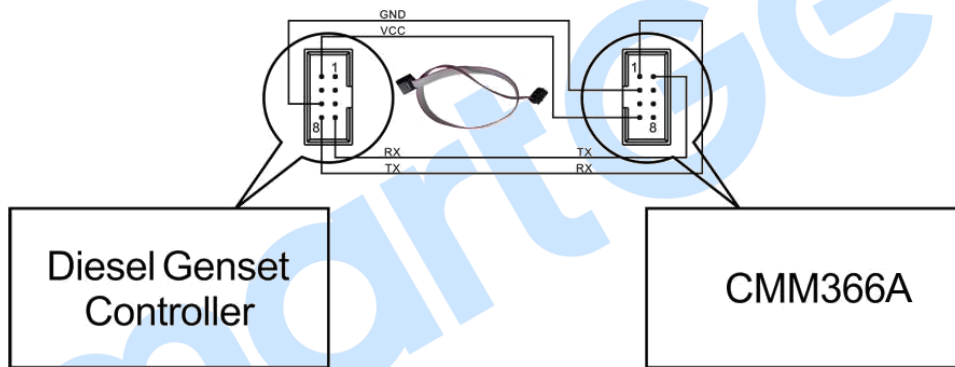

Fig.7 LINK Connection

4.8 USB HOST

Receive genset data information by connecting module A-type USB port (female port) with genset controller USB port via USB cable.

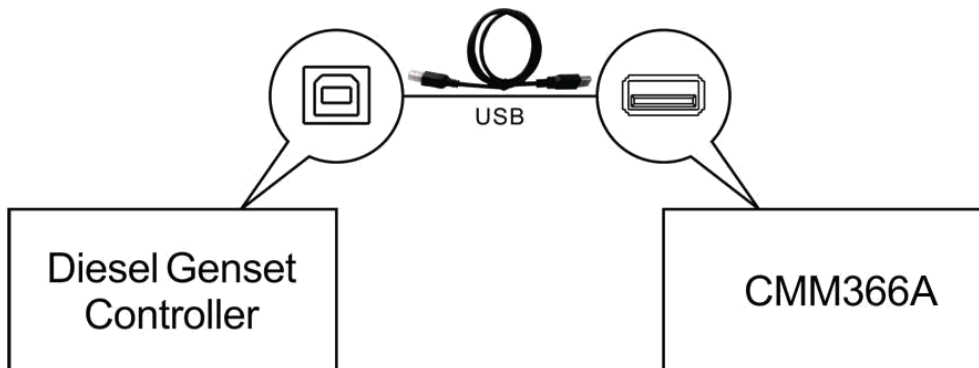

Fig.8 USB HOST Connection

4.9 USB DEVICE

All the parameters can be configured and view CMM366A-4G ID&Login password by connecting USB port with USB disk of PC software.



Fig.9 USB Connect PC Device

4.10 TERMINAL

Table 4 Terminals Description

No.	Function	Cable Size	Note
1	B-	1.0mm ²	Connected with negative of starter battery.
2	B+	1.0mm ²	Connected with positive of starter battery. 3A fuse is recommended.
3	Digital Input 1	1.0mm ²	Active when connect to B-.
4	Digital Input 2	1.0mm ²	Active when connect to B-.
5	Relay Output	Normally Open	Volt free output with 1A DC30V.
6		Common	
7		Normally Close	
8	RS485 B(-)	0.5mm ²	Impedance-120Ω shielding wire is recommended, its single-end earthed.
9	RS485 A(+)	0.5mm ²	
10	RS485 (SCR)	0.5mm ²	
11	RS232 RX	0.5mm ²	RS232 port.
12	RS232 TX	0.5mm ²	
13	RS232 GND	0.5mm ²	

5 PROGRAMMABLE PARAMETERS

5.1 CONTENTS AND SCOPES OF PARAMETERS

Table 5 Parameter Content & Scope

No.	Items	Parameters	Defaults	Description
Gateway				
1	Site Name	(0-65535)		20 Chinese characters, letters or numbers
2	URL	(0-65535)	www.monitoryun.com	40 characters
3	Server Port	(0-65535)	91	
4	Security Code	(0-65535)	123456	16 characters
GPS				
1	GPS Enabled	(0-1)	1	0: Manual Input 1: GPS Location
2	Longitude	((-180)-180)°	0.000000	GPS location, altitude information
3	Latitude	((-90)-90)°	0.000000	
4	Altitude	((-9999.9)-9999.9)m	100.0	
GSM				
1	GSM Enabled	(0-1)	1	0: Disabled; 1: Enabled
2	GPRS Password	Reserved		
3	Message Center	Reserved		
4	PIN Enabled	(0-1)	0	0:Disabled; 1:Enabled
5	APN	(0-65535)	40 characters	
Digital Input				
Digital Input 1				
1	Setting	(0-9)	0	Default: Not used
2	Type	(0-1)	0	0: Active when close 1: Active when open See: Table 6 – Digital Input Ports Content
3	Delay	(0-20.0)	0.0	Action delay
Digital Input 2				
1	Setting	(0-9)	1	Default: Lamp test
2	Type	(0-1)	0	0: Active when close 1: Active when open See: Table 6 – Digital Input Ports Content
3	Delay	(0-20.0)	0.0	Action delay
Digital Output				
1	Setting	(0-14)	0	Default: Not used See: Table 7 – Relay Output Ports Content

NOTE: Configuration of monitoring genset controller model, communication port, communication baud rate, and communication ID need to be set on the platform, and monitoring module need to restart up after all parameters been set.

Table 6 Digital Input Ports Content

No.	Item	Description
0	Not Used	Not used.
1	Lamp Test	All the indicators are illuminated when input is active.
2	Remote Control Inhibited	Cloud start/stop control is prohibited when input is active.
3	Access Alarm Input	Access alarm is uploaded to server when input is active.
4	Fire Alarm Input	Fire alarm is uploaded to server when input is active.
5	Alarm Input	External alarm is uploaded to server when input is active.
6	Reserved	
7	Reserved	
8	Reserved	
9	Factory Test Mode	It is only used for factory test when active.

Table 7 Relay Output Ports Content

No.	Item	Description
0	Not used	Output port won't output when this item is selected.
1	Digital Input 1 Active	Output when auxiliary input 1 is active.
2	Digital Input 2 Active	Output when auxiliary input 2 is active.
3	RS485 Comm. Fail	Output when RS485 communication fails.
4	Network Comm. Fail	Output when Network communication fails.
5	LINK Comm. Fail	Output when LINK communication fails.
6	RS232 Comm. Fail	Output when RS232 communication fails.
7	Common Alarm	Output when there is an alarm.
8	Remote Control Output	Send remote control commands via cloud platform with fixed output delay 20s.
9	Reserved	
10	Reserved	
11	Reserved	
12	Reserved	
13	Reserved	
14	Reserved	

5.2 PC CONFIGURATION INTERFACE

Connecting the USB port of CMM366A-4G communication module with PC USB port to configure the parameters.

Gateway

Site Name	<input type="text"/>
Server Url	<input type="text" value="www.monitoryun.com"/>
Server Port	<input type="text" value="91"/> (0-65535)
Security Code	<input type="text" value="123456"/>

Fig.10 Gateway Configuration

Monitoring

Satellite Num.	0	Altitude	0
Longitude	0.000000	Hardware Ver.	V 1.2
Latitude	0.000000	Software Ver.	V 1.1
Input 1		Issue Date	2017-12-20
Input 2		Module Time	2000-01-01(6) 00:00:19
Output 1			
Module ID	<input type="text" value="3239333734364713003C002F"/>	<input type="button" value="Print"/>	<input type="button" value="Print Setup"/>

Fig.11 Module Monitoring Interface

6 SYSTEM DIAGRAM

One CMM366A-4G module connects with one genset monitor module. It can be connected via RS485 port, LINK port, RS232 port or USB port.

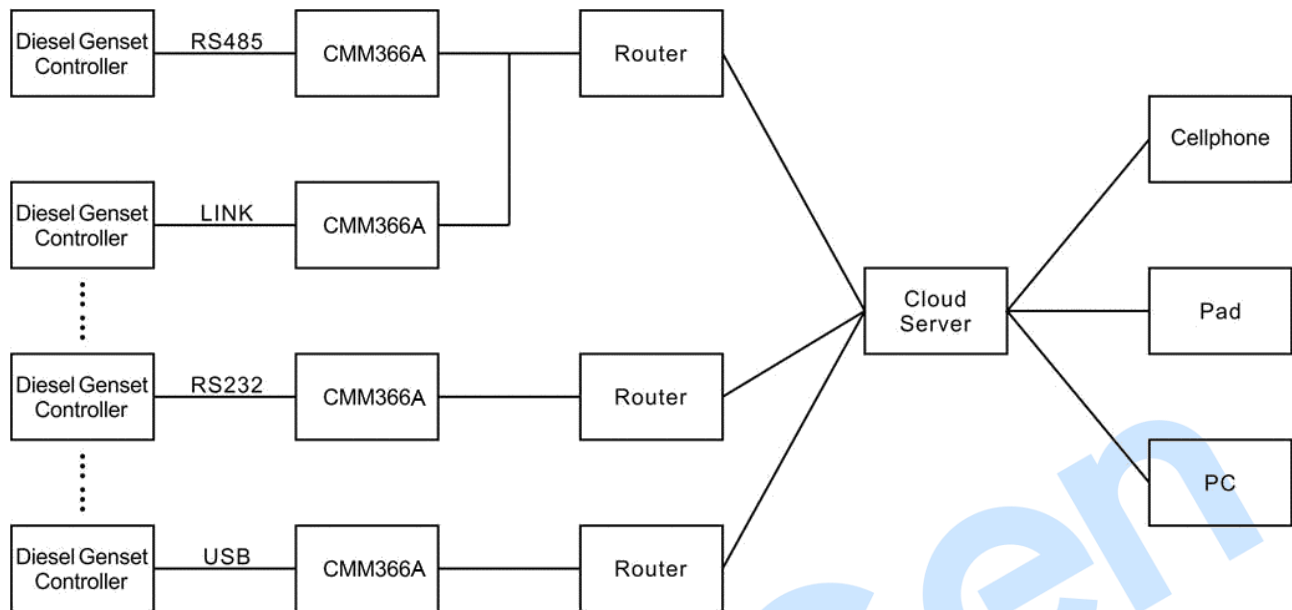

Fig.12 CMM366A-4G System Diagram

7 CASE DIMENSION AND INSTALLATION

2 ways for installation: 35mm guide rail in box or screw (M4) installation as below:

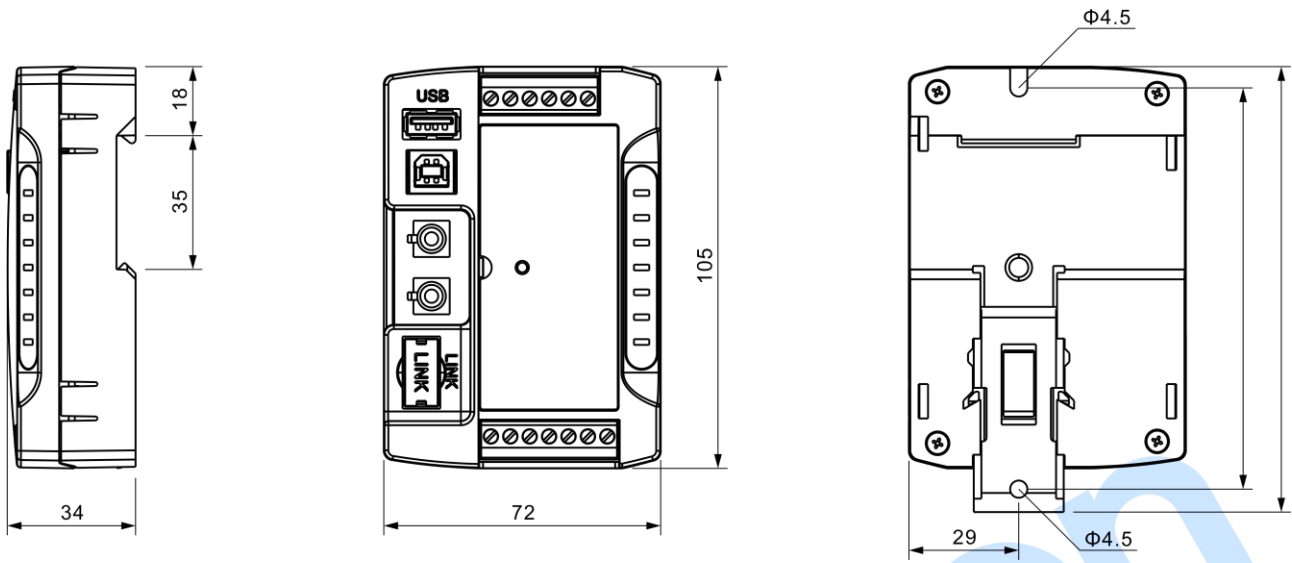

Fig.13 CMM366A-4G Case Dimension

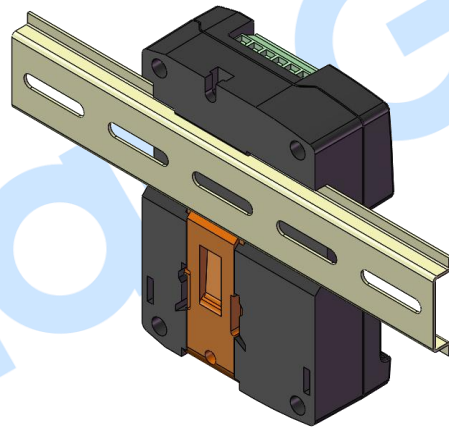

Fig.14 CMM366A-4G Guide Rail Installation

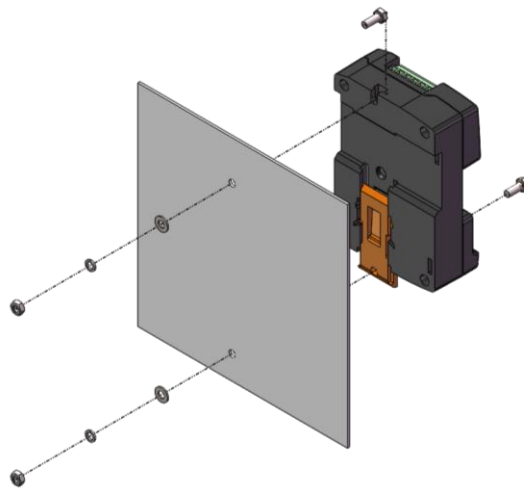

Fig.15 CMM366A-4G Screw Installation

8 FAULT FINDING

Table 8 Fault Finding

Symptoms	Possible Solutions
Controller No Response for Power	Check power voltage; Check controller connection wirings.
GPRS/4G Indicator Not Light	Check SIM card is inserted or not; Check GPRS antenna is connected or not.
GPS Not Gain Location	Check GPS parameters are enabled or not; Check GPS antenna is connected or not and placed outdoor or not.
RS485 Comm. Abnormal	Check connections; Check RS485 port is enabled or not; Check settings of genset ID and baud rate are correct or not. Check RS485's connections of A and B is reverse connect or not.
RS232 Comm. Abnormal	Check connections; Check RS232 port is enabled or not; Check settings of genset ID and baud rate are correct or not.
LINK Comm. Abnormal	Check connections; Check LINK port is enabled or not; Check settings of genset ID and baud rate are correct or not.

9 PACKING LIST

Table 9 Packing List

No.	Name	Quantity	Remark
1	CMM366A-4G	1	
2	Osculum type GSM antenna	1	
3	External GPS antenna	1	
4	Certificate	1	
5	User manual	1	