



SmartGen
ideas for power

**HT SERIES
(HT05M/HT10M/HT22M)
ENGINE WATER HEATER
USER MANUAL**



SMARTGEN (ZHENGZHOU) TECHNOLOGY CO., LTD.



Chinese trademark

SmartGen English trademark

SmartGen — make your generator *smart*

No.28 Jinsuo Road, Zhengzhou, Henan Province, China

Tel: +86-371-67988888/67981888/67992951

+86-371-67981000(overseas)

Fax: +86-371-67992952

Email: sales@smartgen.cn

Web: www.smartgen.com.cn

www.smartgen.cn

All rights reserved. No part of this publication may be reproduced in any material form (including photocopying or storing in any medium by electronic means or other) without the written permission of the copyright holder.

Applications for the copyright holder's written permission to reproduce any part of this publication should be addressed to SmartGen Technology at the address above.

Any reference to trademarked product names used within this publication is owned by their respective companies.

SmartGen Technology reserves the right to change the contents of this document without prior notice.

Table 1 - Software Version

Date	Version	Note
2018-03-23	1.0	Original release.
2018-05-31	1.1	Combined installation instruction and overall dimensions into one drawing; modified technical parameters table; modified front foil drawing.
2020-03-21	1.2	Fixed temperature unit.
2020-08-20	1.4	Added product model HT05M, modified the technical parameter "Off/Reset Temperature" of HT10M-2, HT22M-2.
2020-12-03	1.5	Modified the product weight.

CONTENTS

1	OVERVIEW	4
2	PERFORMANCE AND CHARACTERISTICS	4
3	TECHNICAL PARAMETERS	5
4	INDICATOR	6
5	OPERATION	6
5.1	TEST RUNNING	6
5.2	RESET OVERHEAT PROTECTION.....	6
6	WIRE CONNECTION	6
7	HEATER CONNECTION	6
8	INSTALLATION AND OVERALL DIMENSIONS.....	8
9	CAUTION	8
10	HEATER PACKING LIST	9

SmartGen

1 OVERVIEW

HT Series Water Heater enjoys wide application on various engine coolant preheaters. It has fine cast aluminum enclosure and self-extinguishing engineering plastics end closure, multiple installation ways and easy and convenient use.

If during cranking the outside temperature is lower than 4°C engine coolant and lubricant may condense into solid state and lose their lubricating and cooling properties, which can damage the engine. Engine heater should be installed to ensure normal starting and running of the engine when the outside temperature is lower than 4°C.

HT Series Water Heater combines the following features: cast stainless steel inner pipes and end closure with high corrosion resistance; power, heating and overheat protection light indicators; 3 kinds of heaters with different heating temperature are optional (Standard heater: 40°C; 50°C and 60°C heaters are needed to be customized).

This product is suitable for various engine with (0~13)L displacement.

Please login our company's official website (www.smartgen.com.cn) to select heaters.

2 PERFORMANCE AND CHARACTERISTICS

- Fine cast aluminum enclosure and special surface treatment with high corrosion resistance and high/low temperature capability;
- Stainless steel inner pipes and end closure with high corrosion resistance;
- Coolant temperature is controlled by thermostat which is installed within the heater. It has simple connections and high reliability;
- power, heating and overheat protection light indicators make it easy to observe the heater status;
- There is a water drain valve with seal ring on the bottom of the heater so as to be used when needed;
- Users can press “Test” button to test-run the machine in the extremely high ambient temperature;
- Overheating thermostat provides the protection of dry heating and overheating;
- Multiple installation ways apply to different installation situations;
- This product can work normally at -25°C temperature.

3 TECHNICAL PARAMETERS

Table 2 – Technical Parameters

Items	Description						
Model	HT05M	HT10M	HT22M	HT10M-1	HT22M-1	HT10M-2	HT22M-2
Rated Power	595W (220V 500W)	1190W (220V 1000W)	2200W (220V 1850W)	1190W (220V 1000W)	2200W (220V 1850W)	1190W (220V 1000W)	2200W (220V 1850W)
Rated Voltage	AC240V						
Rated Current	2.5A	5A	9.2A	5A	9.2A	5A	9.2A
Engine Displacement (L)	0~2.5	2.5~7	7~13	2.5~7	7~13	2.5~7	7~13
Thermostat Set Point	(40±3)°C			(50±3)°C		(60±3)°C	
Thermostat Range	Off: (40±3)°C Reset: (25±6)°C			Off: (50±3)°C Reset: (35±6)°C		Off: (60±3)°C Reset: (45±6)°C	
Overheating Thermostat Range	Off: (110±3)°C Reset: Manual (≤95°C)						
Insulating Resistance	≥50MΩ						
Electrical Strength	AC 1.5kV 1min						
Inlet/Outlet Size	3/4"(Φ19mm)						
Max. Water Pressure	0.5MPa						
Protection Level	IP54						
Vibration Resistance	(5~8)Hz (8~500)Hz	Amplitude±7.5mm a=2g		Triaxial Triaxial			
Shock Resistance	Half-sine Wave; a _{peak} =50g;			Triaxial			
Working Conditions	-25°C~+70°C						
Storage Conditions	-30°C~+70°C						
Case Dimensions	208mm×150mm×177mm						
Weight (include accessories)	1.9kg						

4 INDICATOR

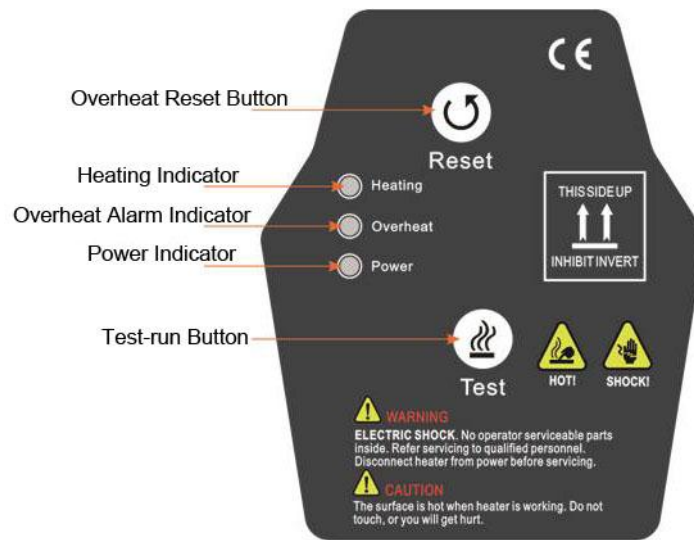

Fig.1 – Panel Indicator Drawing

5 OPERATION

5.1 TEST RUNNING

If the heater is not heating and the overheat protection light is not on, users can press “Test” button to perform the test-run operation.

5.2 RESET OVERHEAT PROTECTION

When overheat alarm indicator is on, heater will enter into overheat protection status and stop heating. If heater temperature falls below the reset temperature limit of overheat protection thermostat (95°C), users need to press reset button and heater enters into auto mode again.

6 WIRE CONNECTION

The supplied power cable is 1.2 m long. Please follow the back cover application diagram when wiring; earth line must be soundly connected to earth.

In the above diagram: L--Phase line (Red), N-Neutral line (Green), E-Earth line (Yellow).

7 HEATER CONNECTION

Please install the heater vertically according to the diagram before use. Paying attention to direction of heater inlet and outlet, and ensure that the heater position is below the lowest water level of the engine and that all the air is exhausted out of the heater and it is topped off with water.

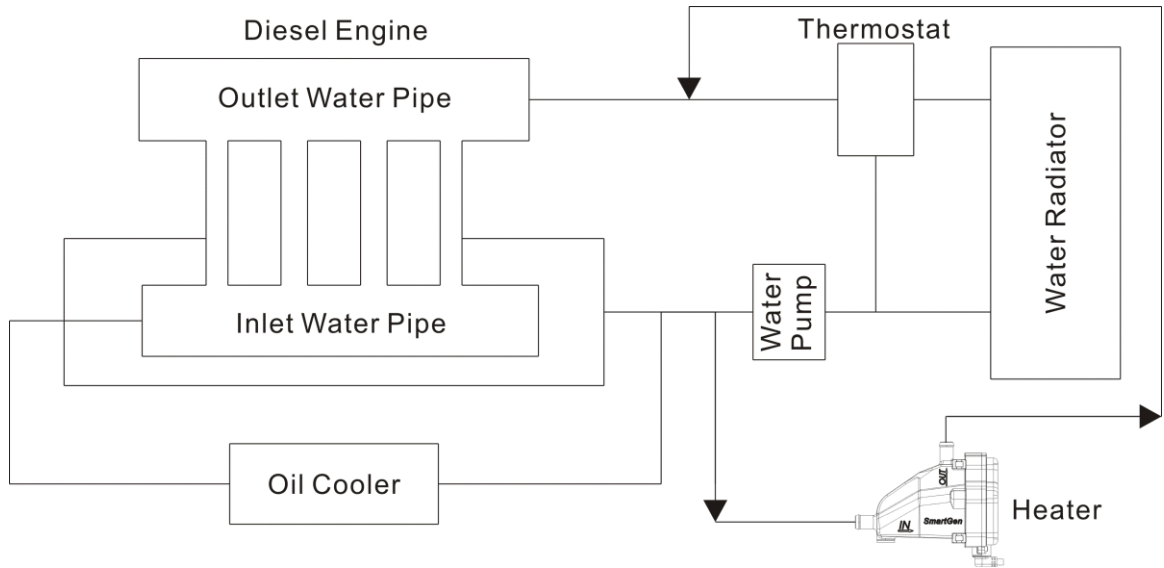

Fig.2 – Heater Operating Schematic Diagram

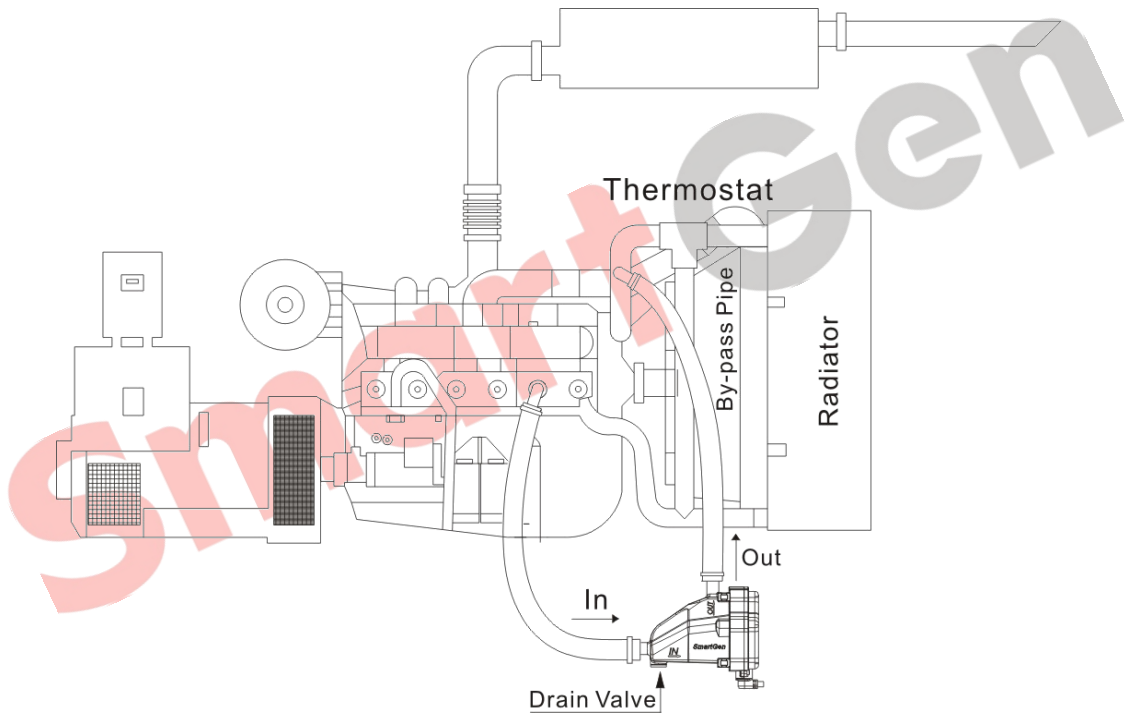

Fig.3 – Heater Position Diagram

8 INSTALLATION AND OVERALL DIMENSIONS

(Unit: mm)

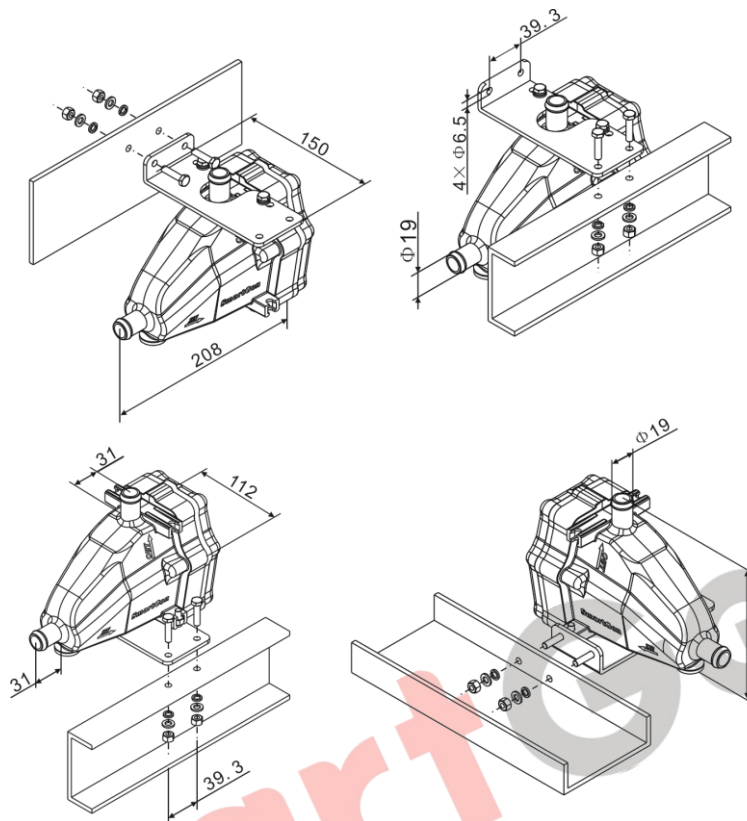

Fig.4 – Installation Dimensions

9 CAUTION

(Unit: mm)

Before starting the machine, ensure that all the air is exhausted out of the heater and it is topped off with coolant. If water is used, please drain it off when generator is stopped to avoid internal corrosion. Otherwise, the remaining water freezes when temperature is lower than 0°C, which can damage the enclosure.

Corresponding antifreeze is strongly recommended.

Earth line must be soundly connected to earth.

Drain valve: Can be opened or closed using hexagonal tools.

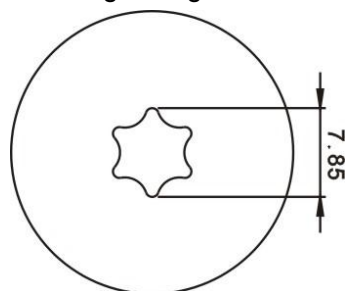

Fig.5 –Water Drain Valve

10 HEATER PACKING LIST

Table 3 – Packing List

No.	Name	Number	Remarks
1	Heater	1	
2	Bracket	1	
3	Flat gasket	4	GB/T 95 6
4	Spring washer	4	GB/T 93 6
5	Hexagon nut	4	GB/T 6170 M6
6	Hexagon screws	4	GB/T 5783 M6x25
7	Hose clamps	4	Φ 18 – Φ33
8	Certificate	1	
9	User Manual	1	

SmartGen