



SmartGen
ideas for power

HAT553V

DUAL POWER ATS CONTROLLER

USER MANUAL

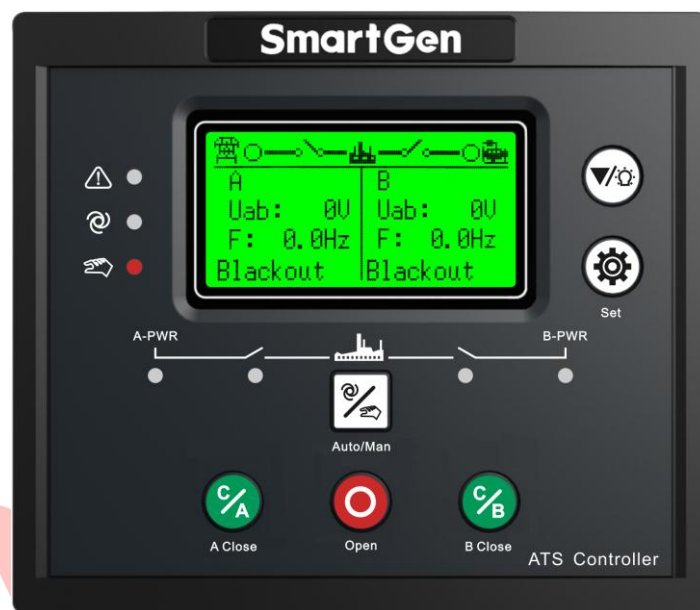

SMARTGEN (ZHENGZHOU) TECHNOLOGY CO., LTD.

CONTENT

1 OVERVIEW.....	5
2 PERFORMANCE AND CHARACTERISTICS.....	5
3 SPECIFICATION	6
4 MEASURED AND DISPLAYED DATA	7
5 OPERATING.....	8
5.1 OPERATION PANEL.....	8
5.2 INDICATOR DESCRIPTION.....	8
5.3 KEY FUNCTION DESCRIPTION	9
6 LCD DISPLAY	9
6.1 MAIN SCREEN.....	9
6.2 SECOND LEVEL INTERFACE.....	10
6.3 STATUS DESCRIPTION	10
6.4 MAIN MENU.....	13
7 GENSET START/STOP OPERATIONS.....	13
7.1 MANUAL START/STOP.....	13
7.1.1 PANEL START/STOP.....	13
7.1.2 REMOTE COMMUNICATION START/STOP.....	14
7.2 AUTO START/STOP.....	14
7.2.1 START REQUIREMENTS.....	14
7.2.2 SCHEDULED START	14
8 PARAMETER CONFIGURATION.....	14
8.1 ILLUSTRATION.....	14
8.2 PARAMETER CONFIGURATION TABLE.....	15
8.3 DIGITAL INPUT/OUTPUT FUNCTION DESCRIPTION	18
8.3.1 INPUT PORT FUNCTION DESCRIPTION.....	18
8.3.2 OUTPUT PORT FUNCTION DESCRIPTION	19
9 EVENT LOG.....	20
10 SWITCH OPERATION RUNNING	21
10.1 MANUAL OPERATION RUNNING	21
10.2 AUTO OPERATION RUNNING	21
10.2.1 AUTO TRANS./RESTORE.....	22
10.2.2 AUTO TRANS./NON RESTORE (ACTIVE FOR MUTUAL BACKUP).....	23
10.2.3 AUTO TRANS./NON RESTORE (ACTIVE FOR MUTUAL BACKUP).....	24
10.2.4 NONE OPEN TRANSFER	24
10.3 AUXILIARY CONTACT FEEDBACK INPUT OF SWITCH OPEN	25
11 COMMUNICATION CONFIGURATION AND CONNECTION	25
11.1 ILLUSTRATION	25
11.2 COMMUNICATION PORT CONNECTION	26
11.3 USB COMMUNICATION PORT.....	27
12 DEFINITION OF CONNECTING TERMINALS.....	27



12.1 DESCRIPTION OF CONNECTING TERMINALS	27
12.2 TYPICAL WIRING DIAGRAM	29
13 INSTALLATION	31
14 TROUBLESHOOTING	32

SmartGen



Chinese trademark

SmartGen English trademark

SmartGen – make your generator *smart*

SmartGen Technology Co., Ltd.

No.28 Jinsuo Road, Zhengzhou, Henan Province, China

Tel: +86-371-67988888/67981888/67992951

+86-371-67981000(overseas)

Fax: +86-371-67992952

Email: sales@smartgen.cn

Web: www.smartgen.com.cn
www.smartgen.cn

All rights reserved. No part of this publication may be reproduced in any material form (including photocopying or storing in any medium by electronic means or other) without the written permission of the copyright holder.

Applications for the copyright holder's written permission to reproduce any part of this publication should be addressed to Smartgen Technology at the address above.

Any reference to trademarked product names used within this publication is owned by their respective companies.

Smartgen Technology reserves the right to change the contents of this document without prior notice.

Table 1 Software Version

Date	Version	Note
2020-11-20	1.0	Original release.

1 OVERVIEW

HAT553V dual power ATS controller is a dual power transfer module integrated with configurable function, automatic measurement, LCD display, and digital communication. It combines digitalization, intelligence and networking together, which realizes automation for measuring and control process, reducing artificial operation mistakes. It is the ideal product for dual power transfer. HAT553V is applicable for non-breaking, one-breaking, and two-breaking switches.

HAT553V dual power ATS controller is made with the microprocessor in the core, which can precisely measure 2-channel 3-phase voltages, make correct judgment and control outputs for occurred voltage abnormal (over voltage, under voltage, over frequency, under frequency, loss of phase, reverse phase sequence). It has compact structure, advanced circuits, simple wiring and high reliability, and can be widely used in electrical automatic control system of electric power, telecommunications, petroleum, coal, metallurgy, railways, municipal administration, intelligent building etc.

2 PERFORMANCE AND CHARACTERISTICS

- System type can be set to: Mains - Generator, Generator - Mains, Mains - Mains;
- 132x64 LCD with backlight, optional Chinese and English display, push-button operation;
- Wide working temperature range (-40°C ~+70°C), suitable for awful environmental places;
- Collect and display 2-channel 3 phase voltage, frequency and phase sequence;
- Display of A power/B power accumulated close times;
- Display of present continuous power supply time and A power/B power accumulated power supply time;
- Over/under voltage, over/under frequency, loss of phase, reverse phase sequence protection functions;
- Auto/Manual mode transfer function: in manual mode, user can control the switch to close or open;
- All parameters are configurable. Password verification is used to prevent non-professional error operations;
- Commissioning can be done on site manually to execute genset start/stop operations;
- Switch Re-closing function is fitted;
- Breaker close output can be set to pulse or steady output;
- 2-channel N wire isolated design;
- Real-time clock (RTC) display, and event log function, which can record 50 data cyclically;
- Scheduled start & stop generator function: running once/monthly/weekly, and on-load/offload running are configurable;
- 1 RS422 isolated communication port, has "remote control, remote communication, remote measuring, remote adjusting" function with ModBus-RTU communication protocol; genset start/stop, ATS close/open can be controlled remotely;
- Suitable for various AC system types (3 phase 4-wire, single-phase 2-wire, and 2-phase 3-wire);
- Modular design, self-extinguishing ABS plastic shell, pluggable terminal, built-in mounting, compact structure with easy installation.

3 SPECIFICATION

Table 2 Technical Parameters

Items	Contents	
Operating Voltage	DC 9.0V~35.0V, continuous power supply; DC reverse connection protection.	
Power Consumption	≤3W (Standby mode: <2W)	
AC Voltage Input	AC system	HAT553V
	3P4W (L-L)	(170~277)V
	3P3W (L-L)	N/A
	1P2W (L-N)	(170~277)V
	2P3W (A-B)	(170~277)V
Rated Frequency	50/60Hz	
Close Relay Capacity	10A AC250V Volts free output	
Open Relay Capacity	10A AC250V Volts free output	
Auxiliary Relay Output 1 Capacity	10A AC250V Volts free output	
Dynamo Start Relay	8A AC250V Volts free output	
Digital Close Input	Active when A-CLOSE and IN COM short connected; Active when B-CLOSE and IN COM short connected;	
Forced to Open Input	GND IN COM connected is active;	
Digital Input 1	GND IN COM connected is active.	
Communication	1. 1 RS422 isolated port, MODBUS Protocol; 2. D-form USB port;	
Case Dimensions	139mmx120mmx50mm	
Panel Cutout	130mmx111mm	
Working Conditions	Temperature: (-40~+70) °C; Humidity: (20~93)%RH	
Storage Condition	Temperature: (-45~+80)°C	
Protection Level	IP65 Gasket: when there is waterproof gasket installed between controller and the control panel;	
Insulation Strength	Apply AC1.5kV voltage between high voltage terminal and low voltage terminal and the leakage current is not more than 3mA within 1min.	
Weight	0.44kg	

4 MEASURED AND DISPLAYED DATA

Table 3 Display Parameters

No.	Measured and Displayed Data Items
1	A/B power phase voltage
2	A/B power line voltage
3	A/B power voltage phase sequence
4	A/B power frequency
5	Present continuous supply time
6	Last time continuous supply time
7	A power accumulated supply time
8	B power accumulated supply time
9	A power accumulated close times
10	B power accumulated close times
11	Close/open status
12	Real time clock
13	Event log
14	Alarm information
15	Controller information

SmartGen

5 OPERATING

5.1 OPERATION PANEL

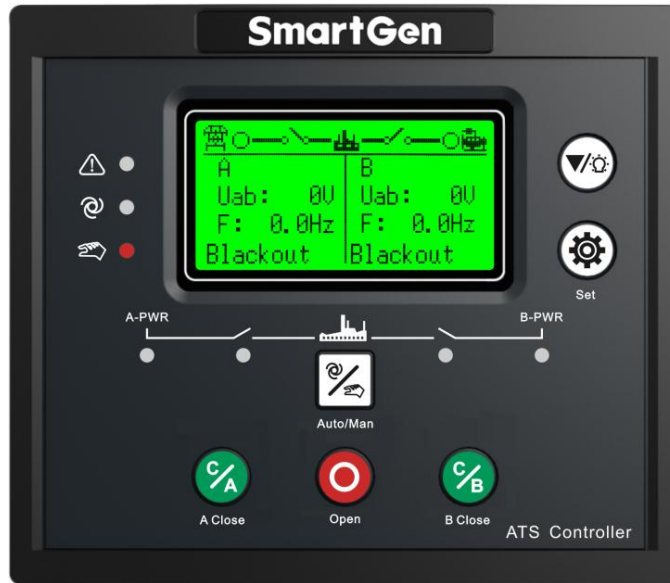

Fig. 1 HAT553V Front Panel







5.2 INDICATOR DESCRIPTION



Table 4 Indicator Description

Indicator Name	Indicator Description
Alarm Indicator	Slow flashing for warning alarms (1time per second); Fast flashing for fault alarms (5 times per second)
Auto Mode Indicator	Light on when current is Auto mode;
Manual Mode Indicator	Light on when current is Manual mode;
A Power Indicator	Always light on when A AC power is normal; flashing when it is abnormal; light off when it is outage.
A Power Close Status Indicator	Light on when A power switch auxiliary contact is active; light off when it is inactive;
B Power Close Status Indicator	Light on when B power switch auxiliary contact is active; light off when it is inactive;
B Power Indicator	Always light on when B AC power is normal; flashing when it is abnormal; light off when it is outage.

5.3 KEY FUNCTION DESCRIPTION

Table 5 Key Function Description

Icon	Function	Description
	Manual/Auto Key	Transfer to Manual or Auto mode;
	A Close Key	Active in manual mode; Press and A power switch closes; load is supplied by A power;
	Open Key	Active in manual mode; Press and load is disconnected;
	B Close Key	Active in manual mode; Press and B power switch closes; load is supplied by B power;
	Set/Confirm	In main screen, press and it enters menu interface; After entering menu interface, confirm key can move the cursor and confirm the set information;
	Down/Lamp Test Key	In main screen, press and scroll down the screen display; After entering menu interface, it can move down the cursor or decrease the value where the cursor is; In main screen, pressing longer is lamp test; when lamp test is done, LCD backlight is illuminated, LCD displays all dark and all LED indicators on the panel are illuminated.

NOTE: Press  and  simultaneously to set backlight on always; Again press both simultaneously or power on afresh to cancel backlight on always.

6 LCD DISPLAY

6.1 MAIN SCREEN

Table 6 Main Screen Display

Item	Display Contents
Home Page	A power status, B power status, Generator start status, switch status; A/B power voltage and frequency;
Power	A power line voltage, phase voltage, phase sequence, frequency; B power line voltage, phase voltage, phase sequence, frequency;
Master Status	A/B master setting; Auto Transfer/Restore status Mutual backup setting;
Alarms	Current alarm information (including warning and fault alarms);
Status Line	Alarm status/working status; Supply system diagram; Real time clock; Status line is displayed on the first row of every page in main screen.

6.2 SECOND LEVEL INTERFACE

Table 7 Second Level Display

Item	Display Contents
Parameter Settings	AC Config. Switch Config. Genset Config. Scheduler Config. Digit Inputs Config. Relay Outputs Config. Module Config.
History Record	Running mode switch event; Start/stop event; Fault event;
Auto Trans./Restore	Auto Trans./Restore; Each Backup;
Test Genset	Manual Start/Stop;
Date and Time Set	Module date and time setting;
Language	Display language setting;
Total Information	Continuous Power Supply Time; Last Continuous Power Supply; A Total Supply Time; B Total Supply Time; A Total Close Numms; B Total Close Numms;
Information	Controller model, version, release date, LCD temp. display and start interface.

6.3 STATUS DESCRIPTION

Table 8 A Power Voltage Status

No.	Item	Description
1	A Available	Delay for A power available detection
2	A Unavailable	Delay for A power unavailable detection
3	Power Normal	Power value is within normal range.
4	Blackout	Voltage is 0.
5	Over Volt	Voltage is above the pre-set upper limit.
6	Under Volt	Voltage is less than the pre-set lower limit.
7	Over Frequency	Frequency is above the pre-set upper limit.
8	Low Frequency	Frequency is less than the pre-set lower limit.
9	Loss Phase	One or two phases are lost among L1, L2, L3.
10	Phase Wrong	Phase sequence is wrong for L1-L2-L3.



Table 9 B Power Voltage Status

No.	Item	Description
1	B Available	Delay for B power available detection
2	B Unavailable	Delay for B power unavailable detection
3	Power Normal	Power value is within normal range.
4	Blackout	Voltage is 0.
5	Over Volt	Voltage is above the pre-set upper limit.
6	Under Volt	Voltage is less than the pre-set lower limit.
7	Over Frequency	Frequency is above the pre-set upper limit.
8	Low Frequency	Frequency is less than the pre-set lower limit.
9	Loss Phase	One or two phases are lost among L1, L2, L3.
10	Phase Wrong	Phase sequence is wrong for L1-L2-L3.

Table 10 Genset Status

No.	Item	Description
1	Genset Start Delay	Delay time before genset start
2	Genset Stop Delay	Delay time before genset stop
3	Schedule Work	Lasting time for scheduled start is displayed when scheduled start is active.
4	Genset Working	Genset start signal outputs.
5	Genset Standby	None genset start signal outputs.

Table 11 Switch Status

No.	Item	Description
1	Ready to Transfer	Enter switch transfer procedure
2	Closing A	A power is experiencing close delay.
3	Opening A	A power is experiencing open delay.
4	Closing B	B power is experiencing close delay.
5	Opening B	B power is experiencing open delay.
6	Transfer Rest	The interval time for switch transfer
7	Closing A Again	Again close time when A power failed to open for the first time, if Again Close Delay is not set to 0.
8	Opening A Again	Again open time when A power failed to close for the first time, if Again Close Delay is not set to 0.
9	Closing B Again	Again close time when B power failed to open for the first time, if Again Close Delay is not set to 0.
10	Opening B Again	Again open time when B power failed to close for the first time, if Again Close Delay is not set to 0.
11	A On Load	A power is closed and A power takes the load.
12	B On Load	B power is closed and B power takes the load.
13	Offload	Switch has been open and load is disconnected.

When controller detects warning alarm, warning alarm becomes active, alarm indicator will slow flashes (1 time per second), and when alarm disappears, alarm indicator will extinguish. Warning alarm isn't latched.

Table 12 Warning Alarm

No.	Item	Description
1	Forced to Open	Forced to open (Non fire cutoff input) action is set to Warning; when it is active, the warning alarms.

When controller detects fault alarm, fault alarm becomes active, alarm indicator will quick flash (5 times per second). Fault alarm is latched, and it disappears until user resets it manually.

Table 13 Fault Alarm

No.	Item	Description
1	A Failed to Close	Switch didn't close properly after A power close signal is stopped to output.
2	A Failed to Open	Switch didn't succeed to close properly after A power open signal is stopped to output.
3	B Failed to Close	Switch didn't close properly after B power close signal is stopped to output.
4	B Failed to Open	Switch didn't succeed to close properly after B power open signal is stopped to output.
5	Forced Open Fault	Forced Open Fault (Non fire cutoff input) action is set to Fault; when it is active, Forced Open Fault alarms.
6	Switch Trip Alarm	Switch trip alarm input is active.
7	Simult. Dual Close	Side switches of A/B power are in closed status.

When reminder information is active, it displays for 2s and then it disappears.

Table 14 Reminder Information

No.	Item	Description
1	Press Reset Alarm	The reminder for manual transfer to auto mode before alarm clear as fault alarm occurs.
2	A Already Close	Set it to one breaking or two breakings; reminder information for pressing A power close key as A power is closed.
3	B Already Close	Set it to one breaking or two breakings; reminder information for pressing B power close key as B power is closed.
4	Already Open	Reminder information for pressing open key as load is disconnected.

Table 15 Other Status Information

No.	Item	Description
1	Start Inhibit	Genset start inhibit input is active.
2	Remote Gen On Load	Remote start on-load input is active.
3	Remote Gen Off Load	Remote start offload input is active.
4	Gen Start Mains NG	Start when Mains is abnormal.
5	Auto Mode	Current is in auto mode.
6	Manual Mode	Current is in manual mode.

6.4 MAIN MENU

In main interface, press  key to enter main menu screen.

<ul style="list-style-type: none"> 1. Exit 2. Parameters Set 3. History Record 4. Auto Trans./Restore 5. Test Genset 6. Date & Time Set 7. Language 8. Total Information 9. Information 	<p>Press Down key and select different parameter line (backlit) and then press Confirm key, to enter related interface.</p>
--	---

NOTE: Password is needed for entering parameter settings, and default password is "01234"; Operators can change the password to prevent others changing controller configurations randomly. Please remember clearly after the change, or it is forgotten, please contact our company personnel.

7 GENSET START/STOP OPERATIONS

7.1 MANUAL START/STOP

7.1.1 PANEL START/STOP

In main screen, press Set/Confirm key to enter main menu interface; select "5. Test Genset" to enter manual start operation screen.

When system type is "A Mains B Gen, A Gen B Mains, A Mains B Mains", the below operation interface is directly entered.

Test Genset	Press Down key to select different parameter line (backlit) and press Confirm key to confirm.
Return	
Genset Stop	
Genset Start	

Genset Stop: Disconnect the outputted genset start signal, which is to control genset stop;

Genset Start: Control genset start signal output, which is to control genset start;

7.1.2 REMOTE COMMUNICATION START/STOP

Through RS422 port and by using Modbus protocol control, remote start or remote stop commands can be issued.

Remote Stop: Disconnect the outputted genset start signal, which is to control genset stop;

Remote Start: Control genset start signal output, which is to control genset start;

7.2 AUTO START/STOP

7.2.1 START REQUIREMENTS

7.2.1.1.1 INPUT PORT START

Set "Remote Start Onload" or "Remote Start Offload" for configurable input ports, and they are cannot be set at the same time.

Remote Start Onload: Genset start outputs, when generating is Ok, GB closes; when it is inactive, disconnect genset start output signal;

Remote Start Offload: Genset start outputs, when mains is Ok, MB closes; when it is inactive, disconnect genset start output signal;

7.2.1.1.2 MAINS ABNORMAL START

When Mains is abnormal, genset start outputs; when generating is Ok, GB closes;

7.2.2 SCHEDULED START

When Scheduled Gen Start is enabled, user can set scheduled start time; Controller will issue start signal when the time is up; when the scheduled start delay time is over start signal is disconnected. Scheduled start can be set to onload or offload.

Scheduled Start Onload: genset start outputs, when generating is Ok, GB closes;

Scheduled Start Offload: genset start outputs, when Mains is Ok, MB closes;

Scheduled Start Cyclical Time can be set to Start Monthly/Weekly/Daily.



Start Monthly: Which month to start, start date and time can be set;

Start Weekly: Start at the same time of several days in a week can be set; for example, from Monday to Friday start at 8:00 every day and last for 10 hours.

Start Daily: Start at the same time for each day can be set.

8 PARAMETER CONFIGURATION

8.1 ILLUSTRATION

In the first page of the main screen, press  key to enter menu screen; select "Parameters Set" and press Confirm key to confirm and enter parameter setting password check interface. Input correct password and it will enter parameter main interface. If password is wrong, then it directly returns to main interface. **Default password is 01234.** In parameter setting page, press longer  to directly exit from this screen and return to main screen.

8.2 PARAMETER CONFIGURATION TABLE

Table 16 Parameter Configuration Items

No.	Item	Range	Default	Description
AC Setting				
1	A Available Delay	(0-3600)s	10	The check time from A power abnormal to normal.
2	A Unavailable Delay	(0-3600)s	5	The check time from A power normal to abnormal.
3	B Available Delay	(0-3600)s	10	The check time from B power abnormal to normal.
4	B Unavailable Delay	(0-3600)s	5	The check time from B power normal to abnormal.
5	Set Master	(0-1)	0	0: A Master 1: B Master
6	System Type Set	(0-2)	0	0: A Mains B Gen 1: A Gen B Mains 2: A Mains B Mains
7	AC System	(0-3)	0	0: 3-Phase, 4-Wire 1: 3-Phase, 3-Wire 2: 2-Phase, 3-Wire 3: Single Phase, 2-Wire Special custom is needed for 3 phase 3 wire
8	Rated Voltage	(0~30000)V	220	Rated voltage value for AC system.
9	Over Volt Set	(0~1)	1	0: Disable 1: Enable
10	Over Volt Value	(0~200)%	120	Voltage upper limit; abnormal when it is over upper limit.
11	Over Volt Return	(0~200)%	115	Voltage upper limit return value; normal when it is lower than return value.
12	Under Volt Set	(0~1)	1	0: Disable 1: Enable
13	Under Volt Value	(0~200)%	80	Voltage lower limit; abnormal when it is lower than this limit.
14	Under Volt Return	(0~200)%	85	Lower limit return value; normal when it is above return value.
15	Rated Frequency	(10.0~75.0)Hz	50.0	Rated frequency value for AC system
16	Over Freq. Set	(0~1)	1	0: Disable 1: Enable
17	Over Freq. Value	(0~200)%	110	Frequency upper limit; abnormal when it is above upper limit.
18	Over Freq. Return	(0~ 200)%	104	Upper limit return value; normal when it is lower than return value.
19	Under Freq. Set	(0~1)	1	0: Disable 1: Enable
20	Under Freq. Value	(0~ 200)%	90	Frequency lower limit value; abnormal when it is lower than this limit.



No.	Item	Range	Default	Description
21	Under Freq. Return	(0~ 200)%	96	Lower limit return value, normal when it is above return value.
22	Loss of Phase	(0~1)	1	0: Disable 1: Enable
23	Phase Sequence Wrong	(0~1)	1	0: Disable 1: Enable
24	PT Fitted	(0~1)	0	0: Disable 1: Enable
25	PT Primary Volt	(30-30000)V	100	
26	PT Secondary Volt	(30-1000)V	100	
Switch Setting				
1	Close Delay	(0.0~20.0)s	5.0	Pulse time for close relay output; continuous output when it is 0.
2	Open Delay	(0.1~20.0)s	5.0	Pulse time for open relay output.
3	Transfer Interval	(1~9999)s	1	Waiting delay time from A open to B close, or B open to A close.
4	After Transfer Delay	(0~20.0)s	0	When closing output ends, it stops after the transfer delay.
5	Again Close Delay	(0~20.0)s	1.0	For the first time switch open failed, then it closes again and close again delay starts; when delay is over, it opens again; if it cannot open, then it issues failed to open alarm signal.
6	Again Open Delay	(0~20.0)s	1.0	For the first time switch close failed, then it opens again and open again delay starts; when delay is over, it closes again; if it cannot close, then it issues failed to close alarm signal.
7	Switch Type	(0~2)	0	0: Two Breaking 1: One Breaking 2: No Breaking
8	Forced Open Action	(0~1)	0	0: Warning 1: Fault
9	Auto Trans/Restore	(0-1)	1	0: Auto Trans/Non Restore 1: Auto Trans/Restore
10	Each Backup	(0-1)	1	0: Inactive 1: Active
11	Open Input Enable	(0~1)	0	0: Disable 1: Enable If this is not connected, please set it to Disable.
12	No Open Transfer Enable	(0~1)	0	0: Disable 1: Enable When it is set to Enable, controller directly transfers to the other circuit from one circuit; and there is not open control output in the transfer process.
Genset Setting				
1	Genset Start Delay	(0~9999)s	1	Delay starts when genset prepares to start;



No.	Item	Range	Default	Description
				when delay is over, controller issues genset start signal.
2	Genset Stop Delay	(0~9999)s	5	Delay starts when genset prepares to stop; when delay is over, controller disconnects genset start signal.
Scheduled Start/Stop Setting				
1	Schedule Gen Enable	(0~1)	0	0: Disable 1: Enable
2	Schedule Load	(0~1)	0	0: Off Load 1: On Load
3	Schedule Period	(0~2)	0	0: Monthly 1: Weekly 2: Daily
4	Schedule Monthly	Month		<input checked="" type="checkbox"/> January <input checked="" type="checkbox"/> February <input checked="" type="checkbox"/> March <input checked="" type="checkbox"/> April <input checked="" type="checkbox"/> May <input checked="" type="checkbox"/> June <input checked="" type="checkbox"/> July <input checked="" type="checkbox"/> August <input checked="" type="checkbox"/> September <input checked="" type="checkbox"/> October <input checked="" type="checkbox"/> November <input checked="" type="checkbox"/> December
5	Schedule Date	(1~31)	1	Date for genset start for each month.
6	Schedule Weekly	Week		<input checked="" type="checkbox"/> Sunday <input checked="" type="checkbox"/> Monday <input checked="" type="checkbox"/> Tuesday <input checked="" type="checkbox"/> Wednesday <input checked="" type="checkbox"/> Thursday <input checked="" type="checkbox"/> Friday <input checked="" type="checkbox"/> Saturday
7	Schedule Hours	(0~23)h	0	Time for scheduled start.
8	Schedule Minutes	(0~59)min	0	
9	Schedule Work Time	(0~30000)min	30	Lasting time for scheduled start running.
Programmable Input Setting				
1	Digital Input 1	(0~20)	0	Not Used
2	Active Type	(0~1)	0	0: Close to Activate 1: Open to Activate
Programmable Output Setting				
1	Relay Output 1 Active Type	(0~1)	0	0: Output(N/O) 1: Output (N/C)
2	Relay Output 1	(0~36)	1	Common Alarm
Module Setting				
1	Power On Mode	(0~2)	0	0: Previous Mode 1: Manual Mode 2: Auto Mode
2	Language	(0~1)	0	0: Simplified Chinese 1: English
3	Password	(00000~65535)	01234	Password for entering parameter setting
4	Module Address	(1~254)	1	Communication address for RS485 network
5	Com Baud Rate	(0~3)	2	0: 2400bps 1: 4800bps 2: 9600bps 3: 19200bps
6	Com USART Parity	(0~2)	0	0: None 1: Odd Parity



No.	Item	Range	Default	Description
				2: Even Parity
7	Com Stop Bit	(1~2)	2	1 or 2 stop bits can be set.
8	Date/Time Setting			
9	Communication Set	(0~3)	0	0: Enable COM Adj/Ctrl 1: Disable COM Control 2: Disable COM Adjust 3: Disable COM Adj/Ctrl

8.3 DIGITAL INPUT/OUTPUT FUNCTION DESCRIPTION

8.3.1 INPUT PORT FUNCTION DESCRIPTION

Table 17 Input Port Function Description

No.	Item	Description
0	Not used	Invalid
1	Reserved	
2	Remote Gen On Load	Genset start outputs; when Mains is normal, gen closes.
3	Remote Gen Off Load	Genset start outputs; when Mains is normal, Mains closes.
4	Test Lamp	LED lamps are all illuminated on the panel, LCD backlight is on, LCD is all dark.
5	Reserved	
6	Reserved	
7	Start Inhibit Input	Inhibit genset start signal output; In auto mode, after stop delay is over, controller disconnects genset start signal output; In manual mode, if genset is started, manual stop is needed; after stop manual start is inactive.
8	Breaker Trip Input	Breaker trip fault input
9	A Master Input	Force to set A Master
10	B Master Input	Force to set B Master
11	A C Key	Same as A Close key on the panel; Auto reset button is needed.
12	B C Key	Same as B Close key on the panel; Auto reset button is needed.
13	Open Key	Same as Open key on the panel; Auto reset button is needed.
14	Man Mode Input	Force controller mode to manual mode.
15	Auto Mode Input	Force controller mode to auto mode.
16	Alarm Reset Input	Reset current alarm
17	Remote Ctrl Inhibit	Remote operation is inactive when this is active.
18	Auto Charge/Rec.	
19	Open IN	Open auxiliary feedback input; if switch needs open IN, please first set Open IN Enable.
20	Reserved	





8.3.2 OUTPUT PORT FUNCTION DESCRIPTION

Table 18 Output Port Function Description

No.	Item	Description
0	Not Used	Invalid
1	Common Alarm	Common alarms include fault alarm, warning alarm.
2	Common Fault Alarm	Fault alarm includes switch transfer failure.
3	Common Warn Alarm	Warning alarms include A phase sequence wrong, B phase sequence wrong, and forced to open.
4	Transition Fault	Switch transfer failures include A failed to close, A failed to open, B failed to close, and B failed to open.
5	Audible Alarm	When fault alarms are active, external annunciator can be connected; After delay for 60s, clear the audible alarm output.
6	Reserved	
7	Reserved	
8	Transition Output	Relay outputs when switch close/open transfers; it stops outputting when transfer is over; shortest output time is 1s.
9	A&B Abnormal	Output when A and B both are abnormal.
10	A Available	Output when A is normal.
11	A Unavailable	Output when A is abnormal.
12	B Available	Output when B is normal.
13	B Unavailable	Output when B is abnormal.
14	Auto Mode	Output when controller is in auto mode.
15	Manual Mode	Output when controller is in manual mode.
16	Genset Start Output	Control genset to start.
17	Breaking Compulsory	Output when Forced to Open is active.
18	A Close Control	Control A switch to close.
19	A Open Control	Control A switch to open.
20	B Open Control	Control B switch to close.
21	B Open Control	Control B switch to open.
22	Open Control	Control A and B switches to open.
23	Reserved	
24	Reserved	
25	A Closed Input	A switch closed status is outputted when switch is at I position.
26	B Closed Input	B switch closed status is outputted when switch is at II position.
27	Opened Input	Switch open status is outputted when switch is at 0 position and it needs to enable open input function and configure input to open input; when this input is active, it outputs.
28	Reserved	
29	Reserved	
30	Reserved	
31	Reserved	

No.	Item	Description
32	Reserved	
33	Reserved	
34	Remote Control	By RS422 communication command control output.
35	Reserved	
36	Reserved	

9 EVENT LOG

In the first page of the main interface, press  key, and enter menu page. Select "Event Log", and then select  to confirm. In this way Event Log interface is entered.

Each item of Event Log contents includes:

Date and time at recording;

Type of record;

Event of record;

A power status;

B power status;

A power 3-phase voltage;

B power 3-phase voltage;

A power frequency;

B power frequency;

Event log can be recorded up to max. 50 items. The first one is the newest. Users can check each item via Down key. When recorded items are over 50, new item will cover the newest record.

Record type includes: Action Event, Warn Event, Fault Event. Fault events are all fault alarms, warn events are all warning alarms.

Table 19 Action Events

No.	Action Event	Description
1	Closing A	Record when A power close is outputted;
2	Closing B	Record when B power close is outputted;
3	Opening A	Record when A power open is outputted;
4	Opening B	Record when B power open is outputted;
5	Simult. Dual Close	Record when A power and B power takes load simultaneously;
6	Genset Start	Record when genset start signal is outputted;
7	Genset Stop	Record when genset start signal is disconnected;
8	Auto Mode	Record when it is transferred to Auto mode;
9	Manual Mode	Record when it is transferred to Manual mode;



10 SWITCH OPERATION RUNNING

10.1 MANUAL OPERATION RUNNING

Press manual/auto transfer key , and manual status indicator is illuminated; Controller is in manual status.

After the switch transfer key is pressed, switch transfers immediately; In the process of transferring, the related indicator flashes; When the switch is transferred to the position, the related indicator is illuminated always.

Table 20 Manual Transfer Key

Icon	Key Name	Function Description
	A Power Close	Press and if load is in open status, A power closes, and load is supplied by A power.
	B Power Close	Press and if load is in open status, B power closes, and load is supplied by B power.
	Open Key	Press and load is disconnected.

10.2 AUTO OPERATION RUNNING

Press manual/auto transfer key , and auto status indicator is illuminated; Controller is in auto status.

In auto mode, controller will transfer switch based on the status of A power and B power, transfer priority and auto trans./restore status to ensure supply for load. The following illustrates control logics by the example of "A power master" and "A Mains B Gen".

10.2.1 AUTO TRANS./RESTORE

When Auto Trans./Restore is set, A power is master; if A power is normal, then A power closes; if A power is abnormal, B power is normal, then A power opens, B power closes; if A power recovers normal, then B power opens, A power closes.

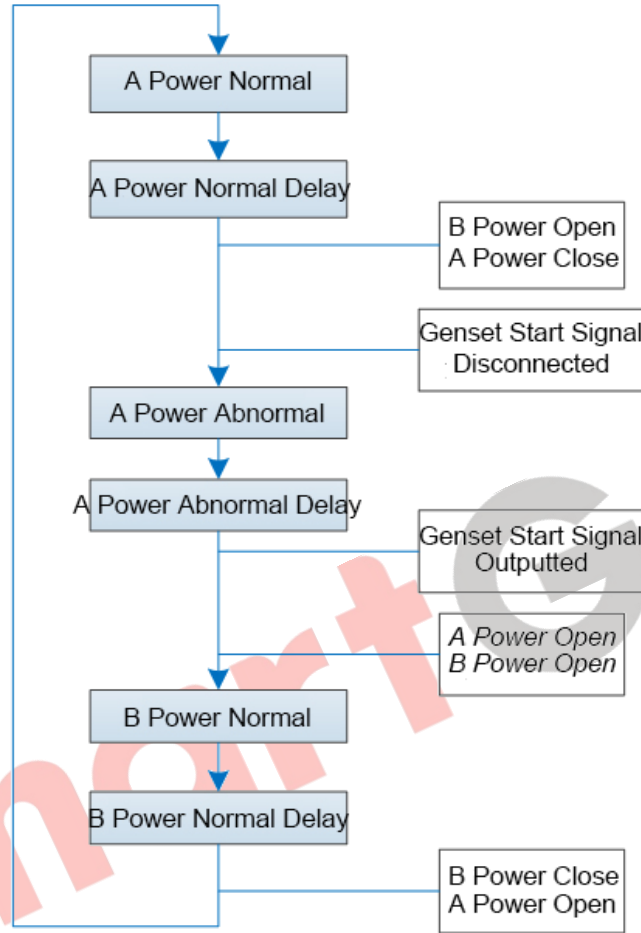

Fig. 2 Auto Trans./Restore Flow Chart

10.2.2 AUTO TRANS./NON RESTORE (ACTIVE FOR MUTUAL BACKUP)

When Auto Trans./Non Restore is set, and Mutual Backup is active, A power is master. If A power is normal, then A power closes; if A power is abnormal, B power is normal, then A power opens, and B power closes; If A power recovers normal, B power is normal, then switch keeps at B power close status.

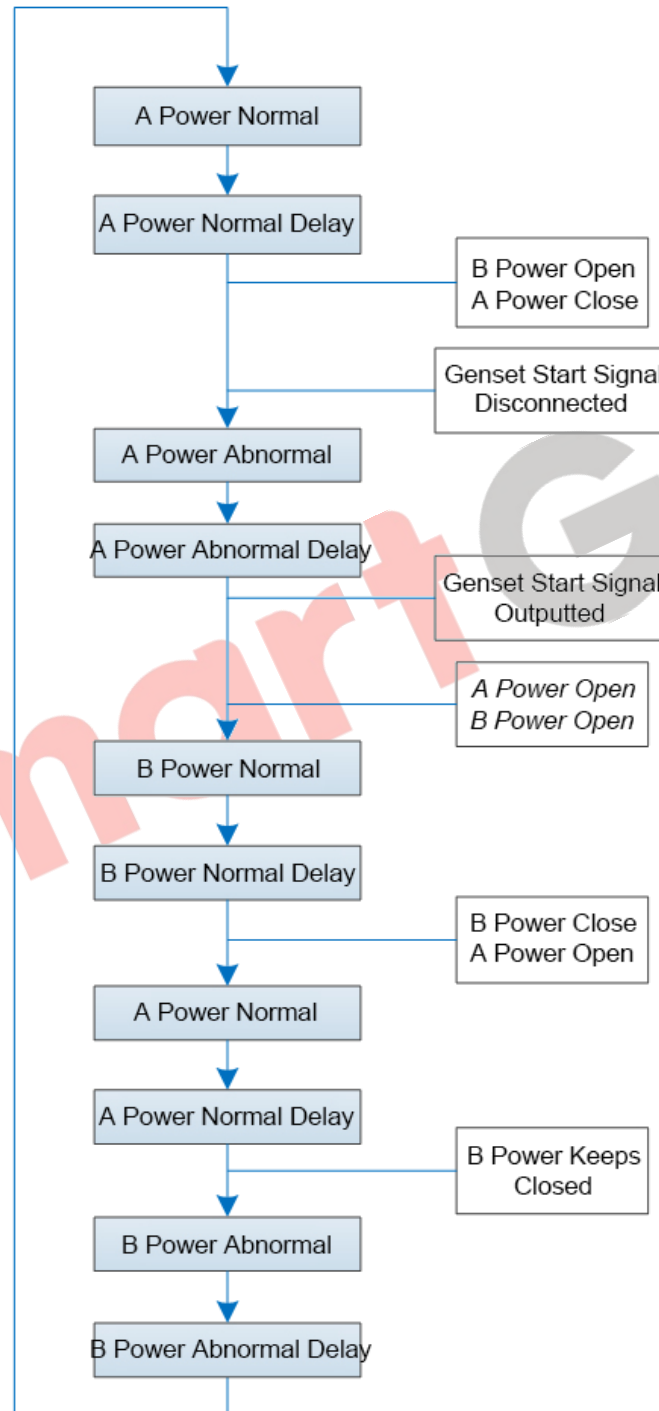

Fig. 3 Auto Trans./None Restore (Active for Mutual Backup) Flow Chart

10.2.3 AUTO TRANS./NON RESTORE (INACTIVE FOR MUTUAL BACKUP)

When Auto Trans./Non Restore is set, and Mutual Backup is inactive, A power is master. If A power is normal, and A power closes, when A power is abnormal, B power is normal, then A power opens, B power closes; if A power recovers normal, then switch keeps at B power close status; when B power is abnormal, B power opens; even through A power is normal, A power doesn't close.

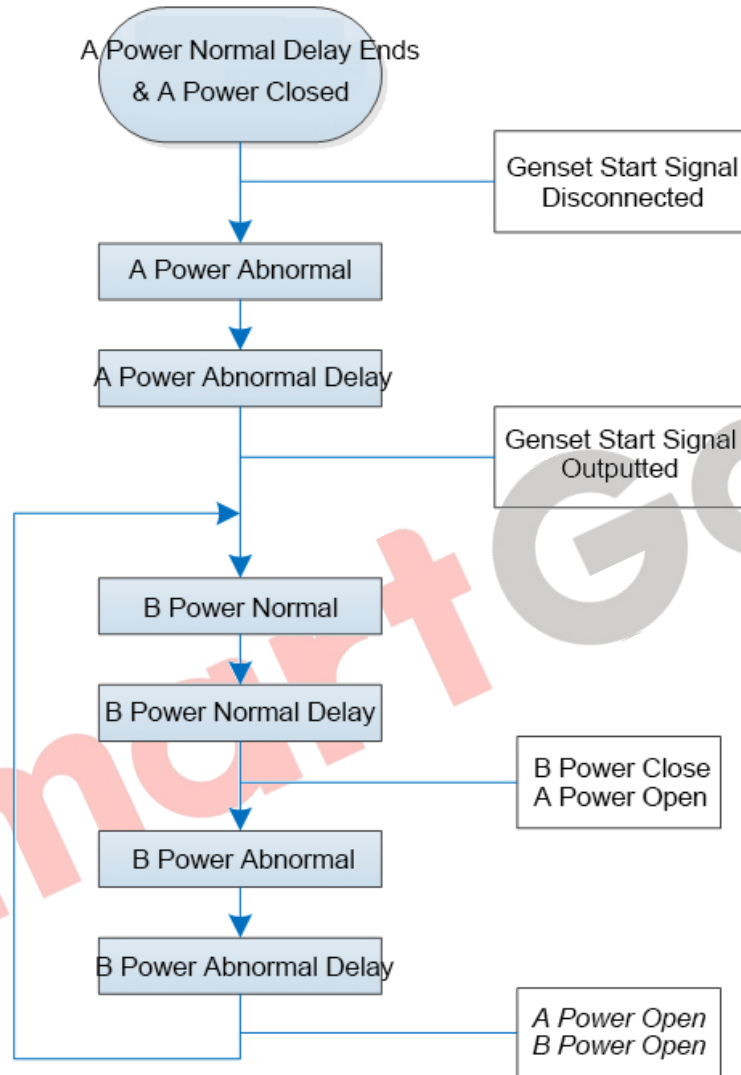

Fig. 4 Auto Trans./Non Restore (Inactive for Mutual Backup) Flow Chart

NOTE: Master power (A power) close needs to transfer to manual mode and by button operation close, otherwise in auto mode, switch only transfers between open and backup power (B power) position.

10.2.4 NONE OPEN TRANSFER

When none open transfer is enabled, controller will not execute open operation. Detailed setting method: in parameter setting interface, enter "switch setting" interface, find "None Open Transfer" Enable and set it enabled. The following illustrates control logics by the example of "A power master", "A Mains B Gen". A power is normal, A power closes; When A power is abnormal, B power is normal, controller issues B power close order; switch directly transfers from A power loading to B power loading. A power open steps in the middle are omitted.

NOTE: this function is only suitable for switches with breakings and switches allowing to transfer directly from A power loading to B power loading.

10.3 AUXILIARY CONTACT FEEDBACK INPUT OF SWITCH OPEN

If switch needs to access to open feedback input, please firstly set open input enabled. Detailed setting method: in parameter setting interface enter "switch setting" interface, find "open input enable" and set it enabled; Then set auxiliary input port 1 "19: Open IN", when auxiliary input 1 detects low electrical level, open input is active.

During the transfer process, if failed to close of A power occurs, A power switch won't execute close action, B power is Ok, and B power close is executed. If failed to open occurs, controller won't execute switch close/open actions.

11 COMMUNICATION CONFIGURATION AND CONNECTION

11.1 ILLUSTRATION

HAT553V dual power transfer controller has RS422 communication port, USB communication port. Between them RS422 communication port allows to connect LAN of open structure. Communication port applies Modbus communication protocol, by the running software on PC or data collecting system, to provide a simple and practical dual power transfer management method of factories, telecommunication, industries and civil buildings, realizing "remote control, remote measuring, remote communicating" functions of dual power monitoring.

For detailed information please refer to *HAT553V Communication Protocol*.

Communication Protocol: Modbus-RTU

Communication Parameters

Module Address	1(Range: 1-254)
Baud Rate	9600bps (2400/4800/9600/19200bps)
Data Bit	8 bit
Parity bit	None (None, Odd, Even)
Stop bit	2-bits (1 bit or 2 bits)

11.2 COMMUNICATION PORT CONNECTION

The HAT553V dual power ATS controller is equipped with RS422 communication port, which can be LAN monitored by RS485 device or by RS422 device. The communication connection is shown as following figure:

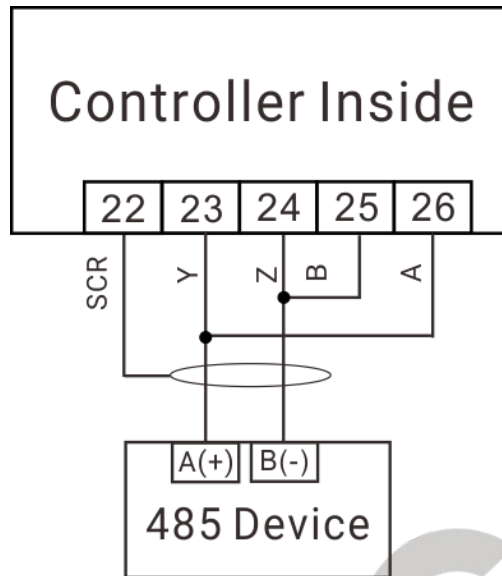

Fig. 5 485 Connecting Diagram

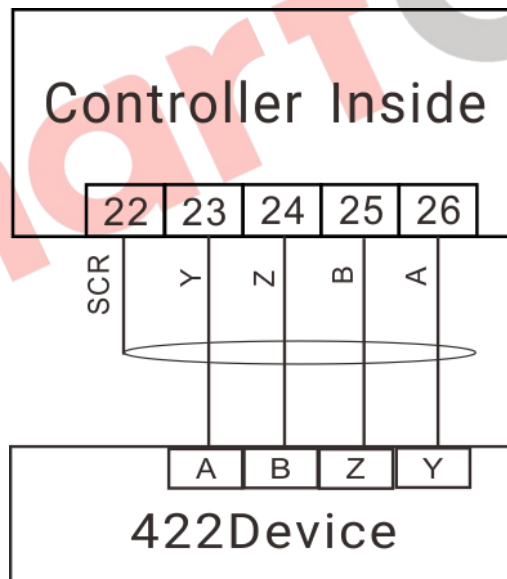

Fig.6 422 Adaptor Connecting Diagram

11.3 USB COMMUNICATION PORT

D-form USB communication port, can be used to connect PC test software and configure parameters and at the same time it can be used for module program upgrade.

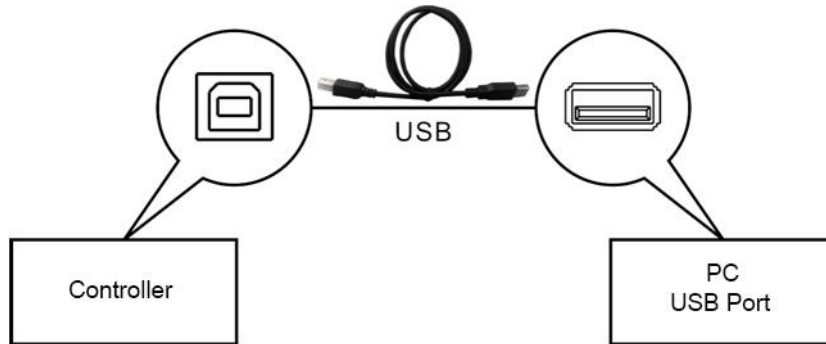

Fig. 7 USB Connecting Diagram

12 DEFINITION OF CONNECTING TERMINALS

12.1 DESCRIPTION OF CONNECTING TERMINALS

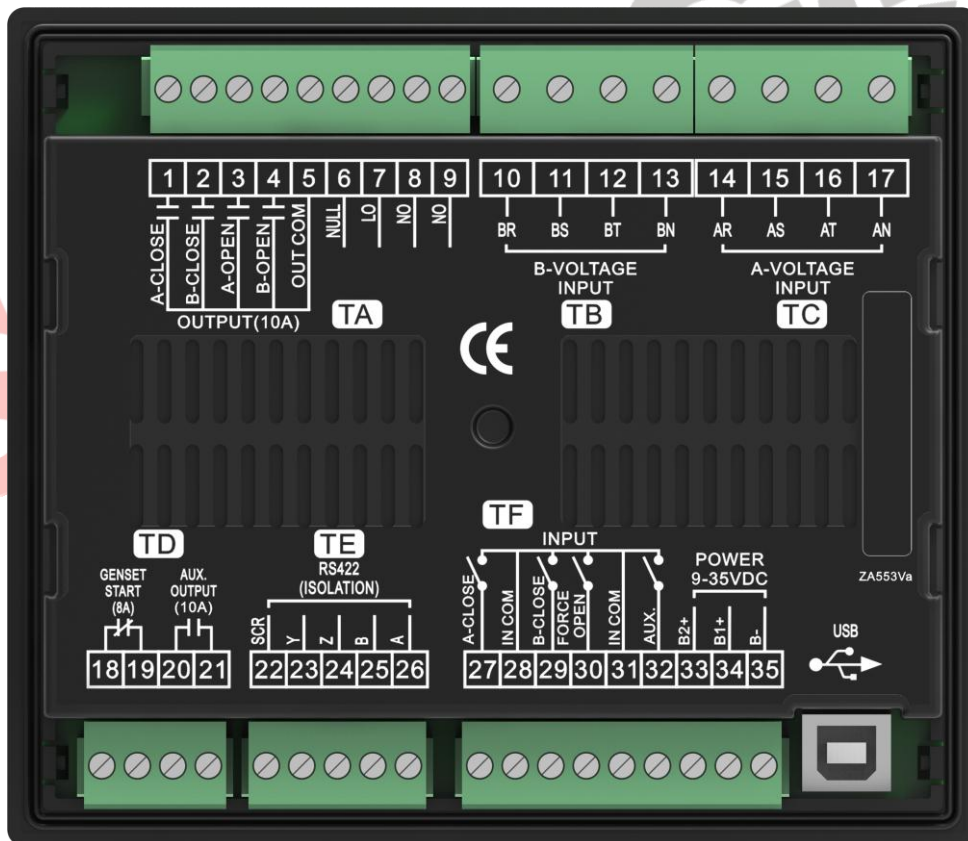

Fig. 8 Controller Rear Panel

Table 21 Terminal Function Description

No.	Item	Function Description	Remark
1	A-CLOSE OUTPUT	Free voltage relay output	A close relay, capacity 10A, connect to OUT COM.
2	B-CLOSE OUTPUT	Free voltage relay output	B close relay, capacity 10A, connect to OUT COM.
3	A-OPEN OUTPUT	Free voltage relay output	A open relay, capacity 10A, connect to OUT COM.
4	B-OPEN OUTPUT	Free voltage relay output	B open relay, capacity 10A, connect to OUT COM.
5	OUT COM	Output common port	
6	NULL	Null terminal	
7	LO	ATS power supply L	Provide power supply for ATS.
8	NO	ATS power supply N	
9	NO		
10	BR	B-VOLTAGE INPUT AC 3 Phase 4 Wire voltage input of B power	For single phase input, only connect BR and BN.
11	BS		
12	BT		
13	BN		
14	AR	A-VOLTAGE INPUT AC 3 Phase 4 Wire voltage input of A power	For single phase input, only connect AR and AN.
15	AS		
16	AT		
17	AN		
18	GENSET START	Start control output port	N/C output, capacity 8A.
19			
20	AUX.OUTPUT	Programmable output 1	Default: common alarm output, N/O output, capacity 10A.
21			
22	SCR	RS422 communication port	Communication port.
23	Y		
24	Z		
25	B		
26	A		
27	A-CLOSE INPUT	Check #1 switch closing status, passive contact input	Active when connect to input common port.
28	IN COM	Input common port	
29	B-CLOSE INPUT	Check #2 switch closing status, passive contact input	Active when connect to input common port.
30	FORCE OPEN INPUT	Forced to Open input	Active when connect to input common port.
31	IN COM	Input common port	
32	AUX. INPUT	Programmable output 1	Default: none used, active when connect to input common port.

No.	Item	Function Description	Remark
33	B2+	DC Power 2 positive input	DC input (8~35)V provide power supply for controller.
34	B1+	DC Power 1 positive input	
35	B-	DC power negative common port	
USB	USB	D form USB communication port	Configure parameters and upgrade program by connecting with PC.

12.2 TYPICAL WIRING DIAGRAM

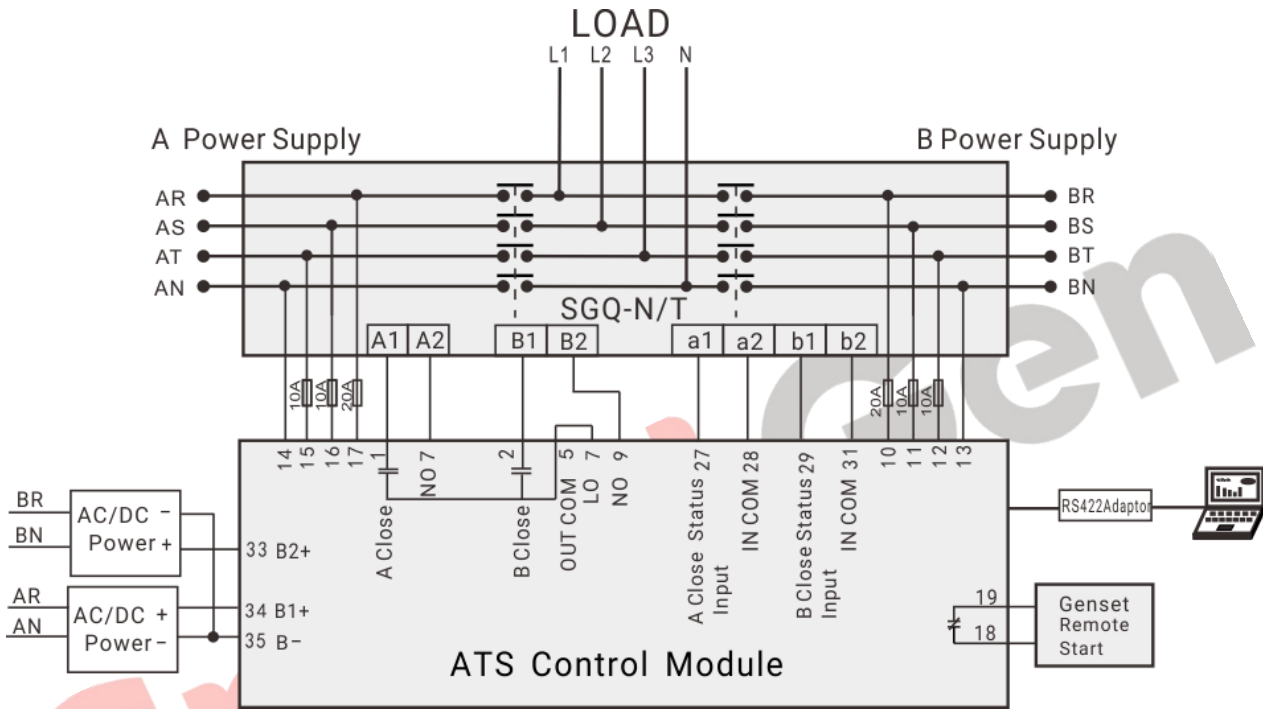

Fig. 9 SGQ-N/T Application Diagram

NOTE: The switch type of SGQ-N/T application diagram is set as none-breaking.

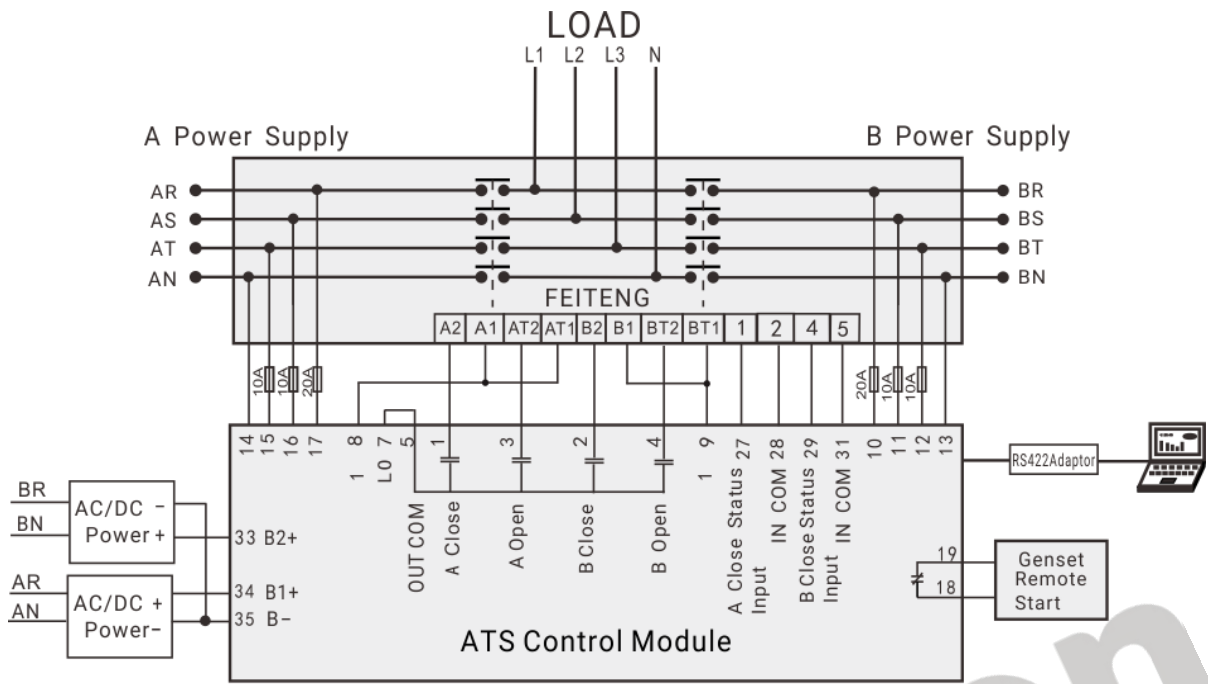

Fig. 10 FEITENG Application Diagram

NOTE: The switch type of FEITENG application diagram is set as two-breaking.

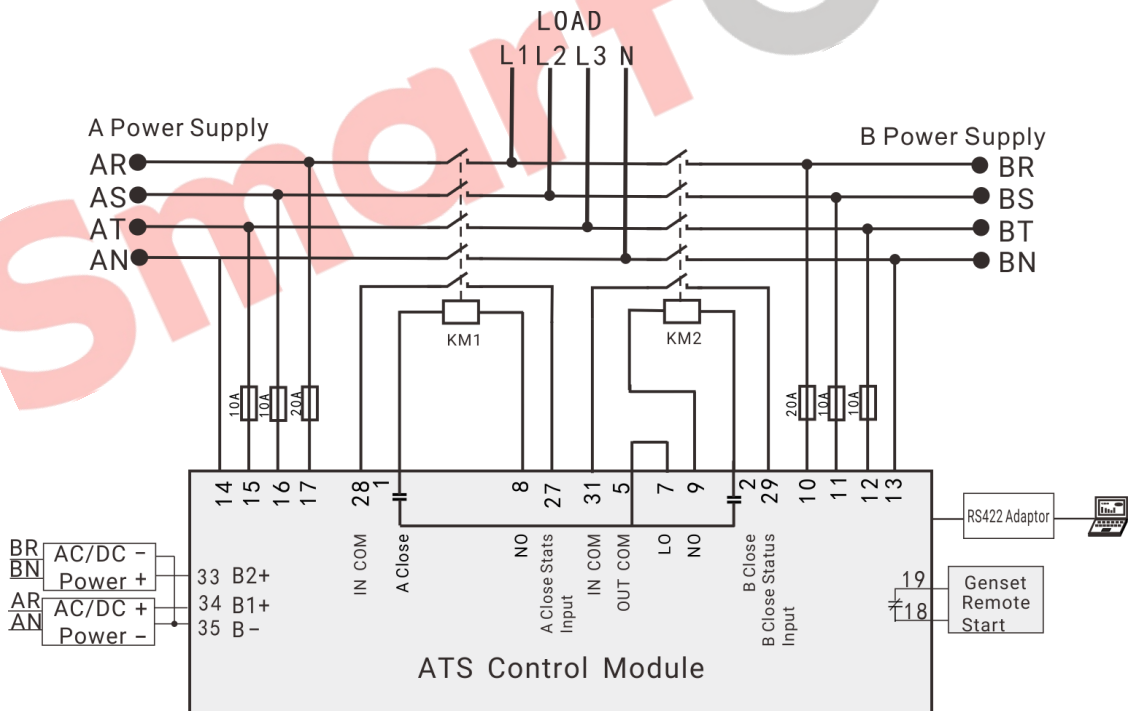

Fig. 11 Contactor Application Diagram

NOTE: The switch type of contactor application diagram is set as two-breaking, the closing time is set as 0, the switch transfer interval is 1s (It depends on the situation).

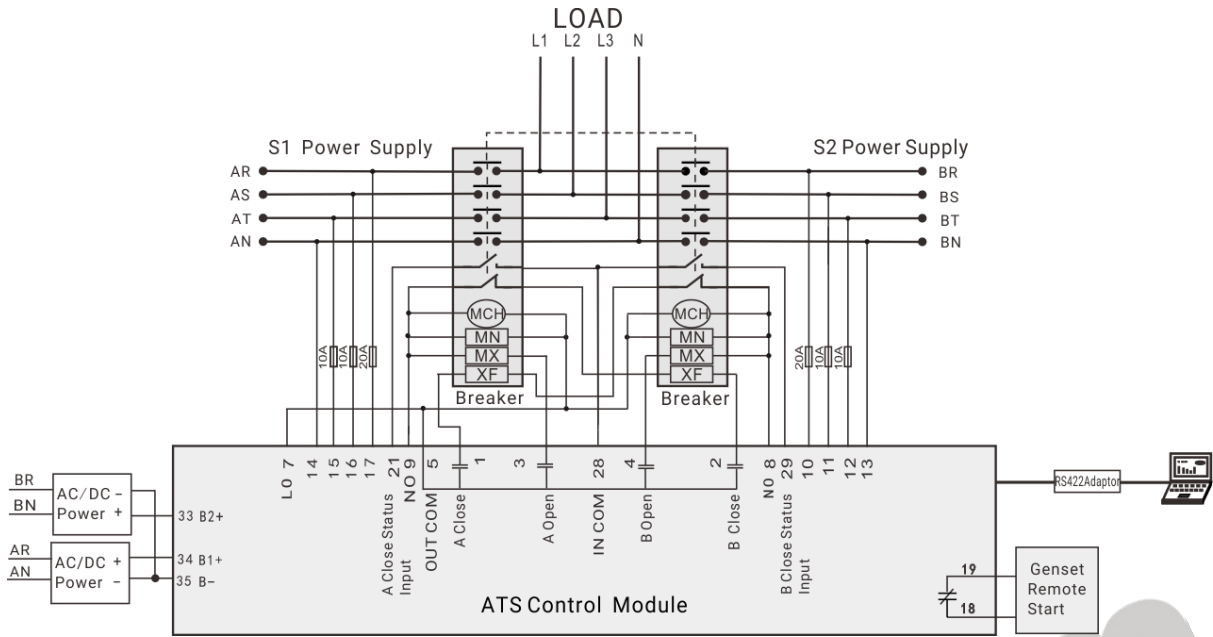

Fig. 12 Breaker (ACB) Application Diagram

NOTE 1: MCH: Stored Energy Motor; MN: Under Voltage Trip; MX: Open Relay; XF: Close Relay;

NOTE 2: The under voltage trip delay of breaker is not less than 1s;

NOTE 3: The switch type is set as two-breaking.

13 INSTALLATION

The controller is designed by panel installation method, and is fixed by clips for installation.

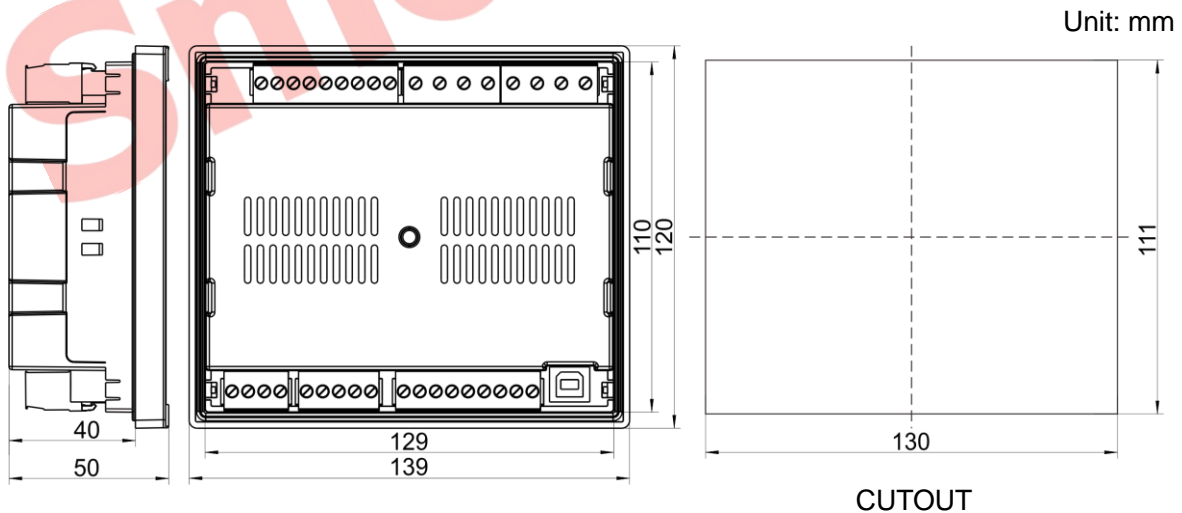

Fig. 13 Overall Dimensions and Cutout

14 TROUBLESHOOTING

Table 22 Troubleshooting

Symptom	Possible Solutions
Controller no response with power	Check DC supply voltage; Check DC fuse; Check AC power;
RS422 communication abnormal	Check ABZY terminals of RS422 are normal or not; Check RS485 transformer is normal or not; Check RS422 transformer is normal or not; Check module address in the parameter settings is correct or not.
Auxiliary Output Error	Check auxiliary output connecting wire, pay attention to N/O and N/C points; Check output port setting function and output type in parameter settings;
Auxiliary Input Abnormal	Check whether aux. input port is GND connected when it's active, and it shall hung up when it is inactive. Check the input setting function of parameter settings and active type.
Switch Transfer Abnormal	Check ATS. Check the connection wirings between the controller and the ATS. Check switch related parameter settings.
Genset Start Control Abnormal	Check system type settings. Check output function settings and output type. Check start/stop function settings of all items.